

PETRO INDUSTRIAL



petroind.com



XD40 & 50 SERIES SPRING REWIND HOSE REEL RANGE

Item code: GRACO-XD40-XD50-AIR-WATER

Engineered to take a beating and still reliably perform in harsh environments so it's ready when you need it. Choose more colors, thread types and hoses or choose the bare reel so you can customize it with your hose. You get a professional look, easier fit and faster performing equipment.

Used in applications requiring long range dispense, transfer or evacuation.

Not for use with gasoline or other flammable fluid. Not approved for use in hazardous or explosive atmosphere locations. For professional use only.

FEATURES:

- Large selection of factory installed hoses to fit your application.
- Rotatable inlet position makes mounting in any application easier.
- A Graco exclusive-breakthrough swivel design allows better flow to get work done faster.
- Avoid reel lockout with an improved ratchet design.
- Heavy-duty welded spool with ribs for added toughness over the long haul.
- Built with NPT, BSPP or BSPT threads to meet worldwide needs.
- Choose the color that fits your shop - blue, yellow or white.

TYPICAL APPLICATIONS:

- Heavy-duty truck dealers.
- Fleet maintenance.
- Mining maintenance.
- Public works garages.
- Construction vehicle maintenance.
- Heavy-duty mobile service trucks.

TYPICAL FLUIDS HANDLED:

- Synthetic based oils.
- Diesel fuel (less than 20% biofuel content).
- Air.
- Water.
- Anti-freeze.
- Waste Oil.

PETRO INDUSTRIAL



petroind.com



TOUGHNESS IS BUILT-IN:

- Standard models come complete with factory installed hoses on the reel.
- Rotatable inlet position makes mounting easier in more applications so there's almost no limit to where it fits.
- A Graco exclusive-breakthrough swivel design allows better flow to get work done faster. Materials are corrosion resistant and strong for long lasting performance.
- Improved ratchet design has one set of teeth instead of two to avoid reel lockout.
- Heavy-duty welded spool is stronger than bolted frames that can loosen with use. Ribs add extra strength for toughness over the long haul.
- Built with NPT, BSPP or BSPT threads means accessories screw right on without the need for adapters. You have fewer leak points...all with global approvals, so you can install it anywhere in the world.
- 7 Year Warranty (1 Year Warranty on Wear Components).

ACCESSORIES:

| Inlet Hose Kits | | Pressure psi (bar) | Hose id in (mm) | Length in (mm) | Hose Inlet |
|--------------------------|--|--------------------|-----------------|----------------|------------|
| 24R111 | Inlet kit for Air/Water & Oil | 11.83 in (300mm) | 1 (25) | 28 (711) | npt(m) |
| 24R112 | Inlet kit for Waste Oil Evacuation | 250 (17) | 1 (25) | 28 (711) | npt(m) |
| 24R115 | Inlet kit for Fuel | 250 (17) | 1 (25) | 28 (711) | npt(m) |
| 24R117 | Inlet kit for Fuel | 150 (10) | 1.5 (38) | 28 (711) | npt(m) |
| Ball Stop Kits | | | | | |
| 237873 | Ball stop kit used for 3/4 in (19.1 mm) hose | | | | |
| 237874 | Ball stop kit used for 1 in (25.4 mm) hose | | | | |
| 24R060 | Ball stop kit used for a 1.25 in (31.75 mm) hose | | | | |
| 24R061 | Ball stop kit used for a 1.5 in (38.1 mm) hose | | | | |
| Arm Kits & Roller Guides | | | | | |
| 24R076 | Support Arm Kit for XD 40 | | | | |
| 24R077 | Support Arm Kit for XD 50 | | | | |
| 24R072 | Roller Guide Kit with Bracket for XD 40 | | | | |
| 24R074 | Roller Guide Kit with Bracket for XD 50 | | | | |
| 237932 | Overhead mounting kit for XD 40. Includes all parts needed for ceiling mounting 1 reel | | | | |

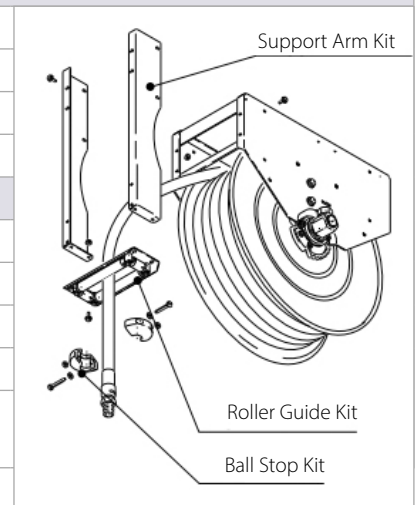

REEL WITH HOSE – RANGE:

| Application | Model Number by Colour | | | Pressure | Hose | | Connection Size | | Operating Temperature | Dimension "F" | |
|----------------------|------------------------|---------|----------|-----------|------------|---------|-----------------|-----------|-----------------------|-----------------------------|---------|
| | Blue | Yellow | White | Psi (bar) | ID in | Length | Inlet in | Outlet in | | | |
| Air, Water | XD 40 | 24P327 | 24P328 | 24P329 | 300 (21) | 1/2 | 100ft (30m) | 1 | 1/2 | -20°-180° F (-28°-82° C) | Model 1 |
| | | 24P330 | 24P331 | 24P332 | | 3/4 | 75ft (23m) | | 3/4 | | |
| | | 24P333 | 24P334 | 24P335 | | 3/4 | 100ft (30m) | | 1 | | |
| | | 24P336 | 24P337 | 24P338 | | 1 | 50ft (15m) | | 1 | | |
| | XD 50 | 24P470 | 24P471 | 24P472 | 300 (21) | 1 | 75ft (23m) | 1 | 1 | | Model 3 |
| | | 24P473 | 24P474 | 24P475 | | | 100ft (30m) | | | | |
| Oil | XD 40 | 24P339 | 24P340 | 24P341 | 2000 (138) | 1/2 | 100ft (30m) | 1 | 1/2 | -40°-180° F (-40°-82° C) | Model 2 |
| | | 24P342* | 24P343* | 24P344* | 1500 (103) | 3/4 | 75ft (23m) | | 3/4 | | Model 1 |
| | | 24R857† | 24R859† | 24R860† | | | | | | | Model 2 |
| | | 24P345 | 24P346 | 24P347 | | | 100ft (30m) | | | | Model 1 |
| | | 24P348* | 24P349* | 24P350* | 1275 (88) | 1 | 50ft (15m) | | 1 | | Model 2 |
| | 24R861† | 24R862† | 24R863† | Model 3 | | | | | | | |
| | XD 50 | 24P476 | 24P477 | 24P478 | 1275 (88) | 1 | 75ft (23m) | 1 | 1 | | |
| Waste Oil Evacuation | XD 40 | 24P351 | 24P352 | 24P353 | 250 (17) | 1 | 50ft (15m) | 1 | 1 | Model 1 | |
| | XD 50 | 24P479 | 24P480 | 24P481 | 200 (14) | 1 1/4 | 35ft (11m) | 1 1/2 | 1 1/4 | Model 4 | |
| | | 24P482 | 24P483 | 24P484 | | | 50ft (15m) | | | | |
| Fuel | XD 40 | 24P354 | 24P355 | 24P356 | 250 (17) | 1 | 50ft (15m) | 1 | 1 | Model 1 | |
| | XD 50 | 24P485 | 24P486 | 24P487 | 250 (17) | 1 | 75ft (23m) | 1 | 1 | Model 3 | |
| | | 24P488 | 24P489 | 24P490 | | | 100ft (30m) | | | | |
| | | 24P491 | 24P492 | 24P493 | | | 35ft (11m) | | | 1 1/2 | 1 1/4 |
| | | 24P494 | 24P495 | 24P496 | 50ft (15m) | Model 4 | | | | | |
| 24P497 | 24P498 | 24P499 | 150 (10) | 1 1/2 | 1 1/2 | | | | | | |

*Truck/bench mount only.

†Overhead or truck mount.

See manual 3A2990 on graco.com for more dimensional information.

DIMENSIONS:

| | XD40 | XD50 |
|-------------------|------------------|------------------|
| A | 11.83 in (300mm) | 11.83 in (300mm) |
| B | 24 in (610mm) | 28.5 in (724mm) |
| C | 26.13 in (664mm) | 30.13 in (765mm) |
| D | 26.4 in (671mm) | 29.4 in (747mm) |
| E | 10.91 in (277mm) | 10.91 in (277mm) |
| F: Model 1 | 16.54 in (420mm) | 17.47 in (444mm) |
| F: Model 2 | 17.47 in (444mm) | 18.24 in (463mm) |

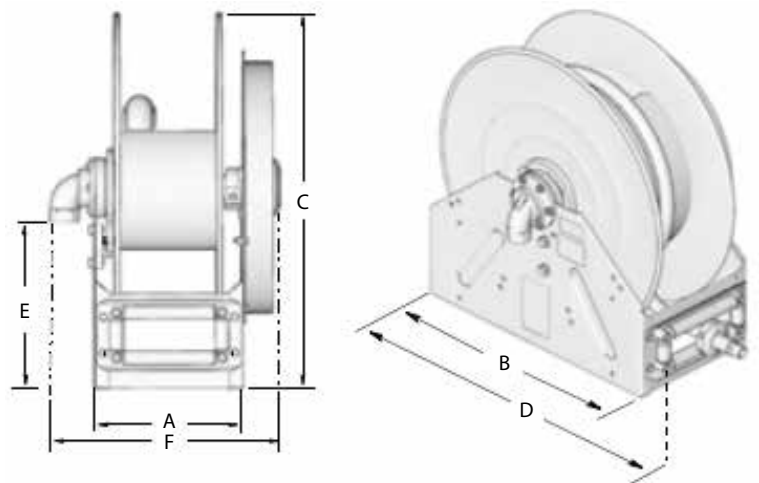

BARE REEL – RANGE:

| Application | | Model Number by Colour | | | Pressure Psi (bar) | Hose | | Connection Size | | Operating Temperature | Dimension "F" |
|---------------|-------------------------|------------------------|-------------|---------|-----------------------|------------|-------------|-----------------|------------|-----------------------------|------------------|
| | | Blue | Yellow | White | | ID in | Length | Inlet in | Outlet in | | |
| Air, Water | XD 40 | 24P313 | 24P315 | 24P316 | 600 (41) | 1/2 | 100ft (30m) | 1 | 1 | -40°–180° F (-40°–82° C) | Model 1 |
| | | | | | | 3/4 | 75ft (23m) | | | | |
| | | 1 | 50ft (15m) | | | | | | | | |
| | | 3/4 | 100ft (30m) | | | | | | | | |
| | XD 50 | 24P455 | 24P456 | 24P457 | | 1 | 75ft (23m) | 1 | 1 | | |
| | | | | | | | 100ft (30m) | | | | |
| Oil | XD 40 | 24P320* | 24P322* | 24P323* | 2000 (138) | 1 | 50ft (15m) | 1 | 1 | ?? | |
| | | | | | | 3/4 | 75ft (23m) | | | ?? | |
| | | 24R854† | 24R855† | 24R856† | | 1 | 50ft (15m) | | | ?? | |
| | | | | | | 3/4 | 75ft (23m) | | | ?? | |
| | | 24P324 | 24P325 | 24P326 | | 1/2 | 100ft (30m) | | | ?? | |
| | | | | | | 3/4 | 100ft (30m) | | | ?? | |
| | XD 50 | 24P458 | 24P459 | 24P460 | | 1 | 75ft (23m) | 1 | 1 | ?? | |
| | Waste Oil Evacuation | XD 40 | 24P317 | 24P318 | | 24P319 | 600 (41) | 1 | 50ft (15m) | 1 | 1 |
| XD 50 | | 24P461 | 24P462 | 24P463 | 1 1/4 | 35ft (11m) | | 1 1/2 | 1 1/2 | ?? | |
| | | | | | | 50ft (15m) | | | | ?? | |
| Fuel | XD 40 | 24P317 | 24P318 | 24P319 | 600 (41) | 1 | 50ft (15m) | 1 | 1 | ?? | |
| | XD 50 | 24P455 | 24P456 | 24P457 | | 1 | 100ft (30m) | 1 | 1 | ?? | |
| | | | | | | | | | | 24P461 | 24P462 |
| | | 50ft (15m) | ?? | | | | | | | | |
| | | 24P464 | 24P465 | 24P466 | | 1 | 75ft (23m) | 1 | 1 | ?? | |
| | | 24P467 | 24P468 | 24P469 | | 1 1/2 | 50ft (15m) | 1 1/2 | 1 1/2 | ?? | |

*Truck/bench mount only.

†Overhead or truck mount.

See manual 3A2990 on graco.com for more dimensional information.