



3:1 MINI FIRE-BALL 225 PUMP RANGE

Item code: GRACO-225-3:1

Typical applications are continuous duty, maintenance facility dispensing motor oil, gear oil, automatic transmission fluid, hydraulic fluid.

FEATURES:

- In-line design with fewer parts for less pump wear.
- Differential air motor ensures smooth pumping.
- Double-acting pump provides reliable fluid flow.
- Thick cast aluminum air motor housing for unmatched durability.
- Corrosion resistant design extensively utilizes liquid salt nitriding, nickel plating and chrome on key components.
- Precision ground induction hardened displacement rod for minimal wear.
- Guided inlet check valve for superior priming.
- Non-corrosive design (metal parts made of SST, aluminum and chrome) for long life.
- No metal-to-metal contact – longer pump life.
- Open exhaust port provides continuous operation without icing.

SPECIFICATIONS & PERFORMANCE:

- Cycles per Gallon: 43.5 (11.4 liters)
- Fluid Flow gal/min @ 80 cpm: 1.84 (7.0 liters)
- Maximum Fluid Pressure: 540 psi (37 bar)
- Air Motor Effective Diameter: 2.25 in (57.2 mm)
- Air Operating Range: 40-180 psi (2.8-12 bar)
- Approx. Air Use and Flow @ 100 psi and 80 cpm: 8.5 scfm @ 2.1 gpm, (0.241 m³/min @ 7.9 lpm)
- Wetted Materials: Steel, Buna-N, Polyurethane, Aluminum, Rulon®
- Annual Usage: Up to 35,500 gal (132,000 l)
- Line Length: Up to 250 ft (76.2 m)
- Air Inlet Port Size: 3/8 in npt(f)
- Fluid Inlet Port Size: 1-1/2 in npt(f)
- Fluid Outlet Port Size: 1/2 in npt(f)
- Dispense Points: 1 to 2

MINI FIRE-BALL 225 3:1 PUMP – ORDERING INFO:

Code	Description
248097	3:1 Universal Oil Pump with suction tube (15C502) and bung adapter (222308)
246775	3:1 Universal Oil Pump

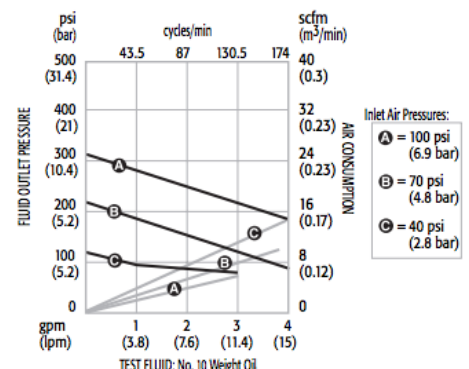

MINI FIRE-BALL 225 & FIRE-BALL 300 – ORDERING INFORMATION:

Packages	Portable	Cover-Mounted	Bung-Mounted		Universal
Container Size	16 gal (60 l)		55 gal (200 l)		275 gal (1040 l)
Mini Fire-Ball 225, 3:1 Package	246903 ⁽⁴⁾	246904 ⁽⁴⁾	246906 ⁽⁴⁾	246907 ^{(3), (4)}	
Mini Fire-Ball, 225 3:1 Pump	248097 ^{(1), (3)}				246775
Fire-Ball 300, 5:1 package	225728 ^{(2), (4)}	225094 ^{(3), (4)}	225642 ^{(3), (4)}	225640 ^{(3), (4)}	225931 ^{(3), (4)}
Fire-Ball 300 Pump	203872		203857	204254	222087
Dispense/Hose Fitting Kit	237075	222063			222062
Fluid Hose	6 ft x 1/2 in (1.8 m x 12.7 mm)				1.5 ft x 1/2 in (0.5 m x 9.5 mm)
Air Hose	–	6 ft x 3/8 in (1.8 m x 9.5 mm)			1.5 ft x 3/8 in (0.5 m x 9.5 mm)
Air Regulator	224512		–	–	–
Cover	204574		200326	–	–
Caster Base	203622	–	–	–	–
Bung Adapter for 300, 5:1	–	–	–	222308	
225, 3:1 Manual	309868				
300, 5:1 Manual	307884	307883			306520

⁽¹⁾ 248097 includes suction tube (15C502) and bung adapter (222308)

⁽²⁾ Use 3/8 in (9.5 mm) installation kit (224512) as required

⁽³⁾ Use 3/8 in (9.5 mm) air regulator 109075 as required; must be ordered separately

⁽⁴⁾ Order low-level cut-off 203688 (1 1/2 inch NPT) separately for metered dispense systems



Portable



Cover Mounted



Bung Mounted



Universal

FIRE-BALL 425 PACKAGE – ORDERING INFORMATION:

Packages	Cover-Mounted	Bung-Mounted	Universal	Wall-Mounted
Container Size	55 gal (200 l)		Universal	
Fire-Ball 425, 3:1 Package	–	–	–	244846 ⁽³⁾
Fire-Ball 425, 3:1 Pump	–	–	–	237526
Fire-Ball 425, 6:1 Package	–	–	–	244628 ⁽³⁾
Fire-Ball 425, 6:1 Pump	–	–	–	238108
Fire-Ball 425, 10:1 Package	225782 ^{(1) (2)}	225786 ^{(1) (2)}	225853 ^{(1) (2)}	244847
Fire-Ball 425, 10:1 Pump	222065	222095	205626	205626
Hose/Fitting Kit	222066		222068	
Fluid Hose	6 ft x 3/4 in (1.8 m x 19.05 mm)		1.5 ft x 3/4 in (0.5 m x 19.05 mm)	
Air Hose	6 ft x 1/2 in (1.8 m x 12.7 mm)		1.5 ft x 1/2 in (0.5 m x 12.7 mm)	
Cover	200326	–	–	–
Filter Regulator	–	–	–	217072
Air Shutoff Valve	–	–	–	110225
Fluid Shutoff Valve	–	–	–	108537
Wall Mount Bracket	–	–	–	238245
Instruction Manual	307883		306520	309351

⁽¹⁾ Use 1/2 in (12.7 mm) air regulator (104266) and air pressure gauge (100960) as required; must be ordered separately—see mounting accessories section

⁽²⁾ Order low-level cut off (203688) separately for metered dispense systems—see mounting accessories section

⁽³⁾ Includes pump plus: Filter Regulator (217072), Hose and Fitting Kit (222068), Air Shutoff Valve (110225), Fluid Shutoff (108537), Wall Mount Bracket, (238245)

MINI FIRE-BALL 225, 3:1 PUMP PACKAGES:

Code	Description
248623*	Includes: Mini Fire-Ball 225, 3:1 Universal pump with bung adapter and down tube (248097), SD Series reel with 50 ft (15.2 m) x 1/2 in (12.7 mm) fluid hose (HPM65B), LDM5 meter (256215)
248622*	Includes: Mini Fire-Ball 225, 3:1 Universal pump with bung adapter and down tube (248097), SD Series reel with 25 ft (7.6 m) x 1/2 in (12.7 m) fluid hose (HPM33B), LDM5 meter (256215)

* Order 218549 (1/2 in x 24 in) hose reel inlet kit separately NOTE: Tanks not included.

FIRE-BALL 300, 5:1 PUMP PACKAGES

Code	Description
241633*	Includes: Fire-Ball 300, 5:1 pump universal (203876), 3/8 in (9.5 mm) regulator/gauge (109075), 3/8 in (9.5 mm) x 3/8 in (9.5 mm) nipple (156849), 2 in (50.8 mm) bung adapter (222308), SD Series reel with 25 ft (7.6 m) x 1/2 in (12.7 mm) hose (HPM33B), SDM5 meter (255350)
224541*	Includes: Fire-Ball 300, 5:1 pump universal (203876), 3/8 in (9.5 mm) regulator/gauge (109075), 3/8 in (9.5 mm) x 3/8 in (9.5 mm) nipple (156849), 2 in (50.8 mm) bung adapter (222308), SD Series reel with 50 ft (15.3 m) x 1/2 in (12.7 mm) hose (HPM65B), 18 in (45.7 cm) hose (220598), 90° swivel (inlet on hose reel) (157416), SDM5 meter (255350)
244038*	Includes: Fire-Ball 300, 5:1 pump universal (203876), 3/8 in (9.5 mm) regulator/gauge (109075), 3/8 in (9.5 mm) x 3/8 in (9.5 mm) nipple (156849), 2 in (50.8 mm) bung adapter (222308), SD Series reel with 50 ft (15.3 m) x 1/2 in (12.7 mm) hose (HPM65B), 18 in (45.7 cm) hose (220598), 90° swivel (157416), SDP5 meter (255200)
224534*	Dispensing from Bench-Top Tanks with Fire-Ball 300, 5:1 Pump Package. Includes: Fire-Ball 300, 5:1 pump, Universal (203876), 3/8 in (9.5 mm) regulator/gauge (109075), Air filter (106148), 3/8 in (9.5 mm) x 3/8 in (9.5 mm) nipple (156849), SD Series reel with 50 ft (15.3 m) x 1/2 in 12.7 mm hose (HPM65B), Drain valve (106151), 72 in (182.9 cm) hose kit (222063), Thermal relief valve (237893), 90° swivel (157416), SDM5 Meter (255350)

* Order 218549 (1/2 in x 24 in) hose reel inlet kit separately NOTE: Tanks not included.

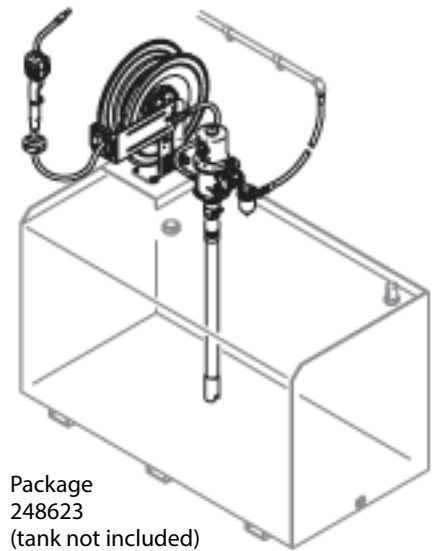

Package
248623
(tank not included)

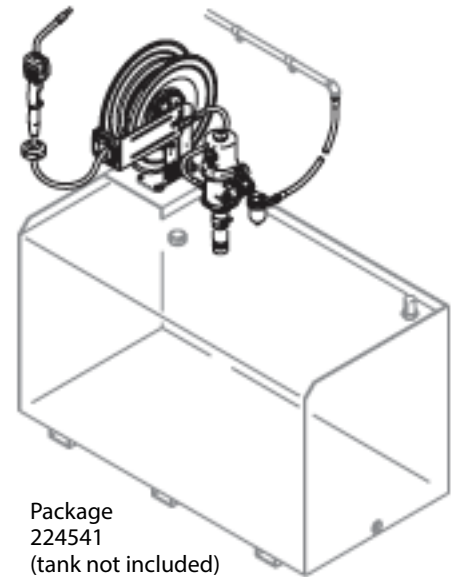

Package
224541
(tank not included)

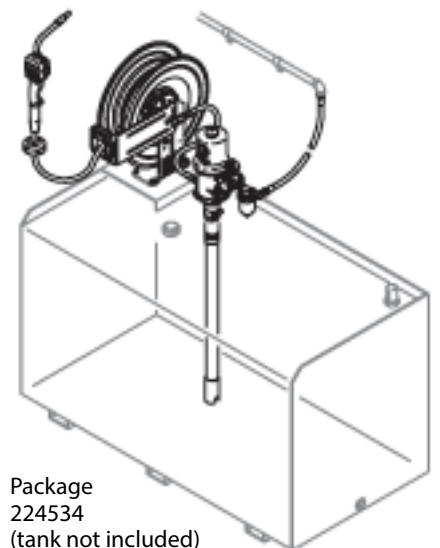

Package
224534
(tank not included)