

FPQ 150
REFUELLER VANE PUMP

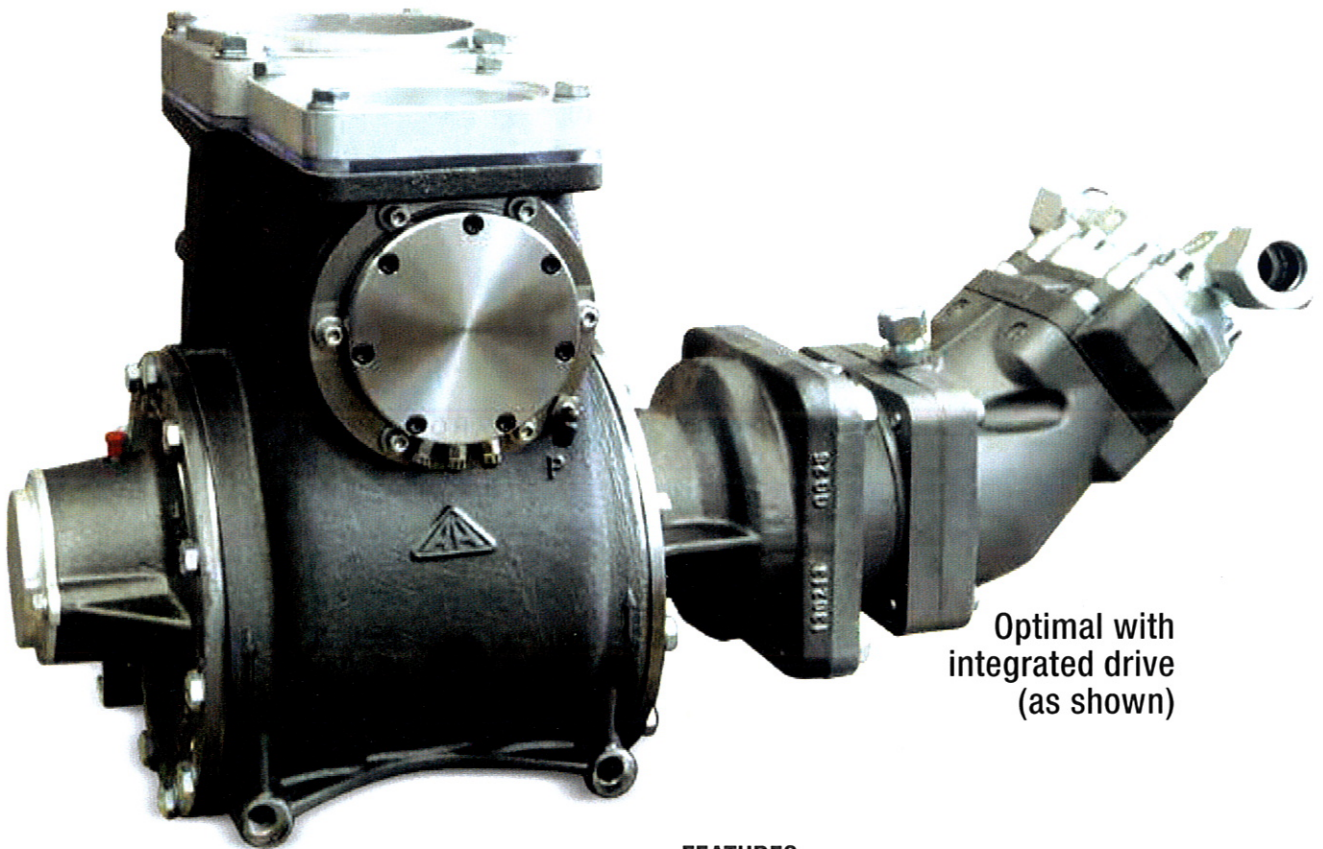

SELF PRIMING VANE PUMP

Depending on selected pump size up to 4000 l/min with $\Delta p = 8$ bar



Optimal with
integrated drive
(as shown)

Ex II 2G cT3 CE certified.
Operation without a flame arrestor is possible
in compliance with the certified ATEX conditions.

FEATURES

- High efficiency
- Low noise emission
- Small size
- Light weight

By current modelling using
numerical methods

- Pneumatic (remote controllable)
or wire spring bypass valve

FPQ 150 REFUELLER VANE PUMP



DIMENSIONS

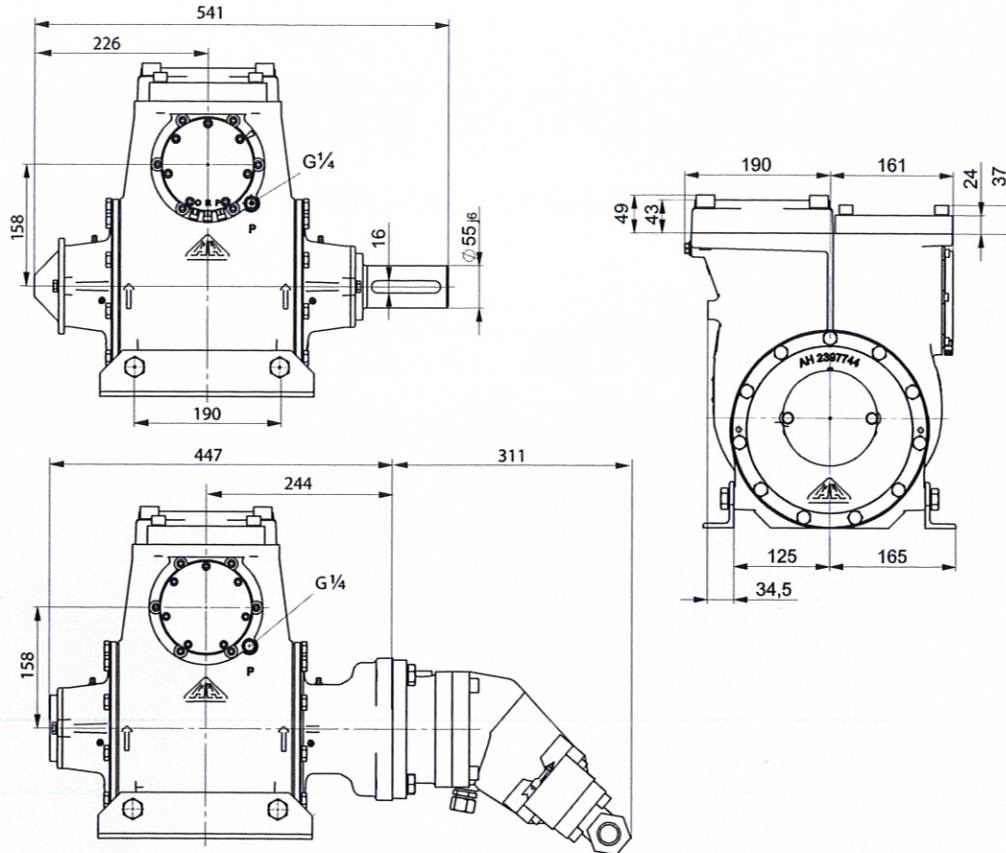

FLOW RATE

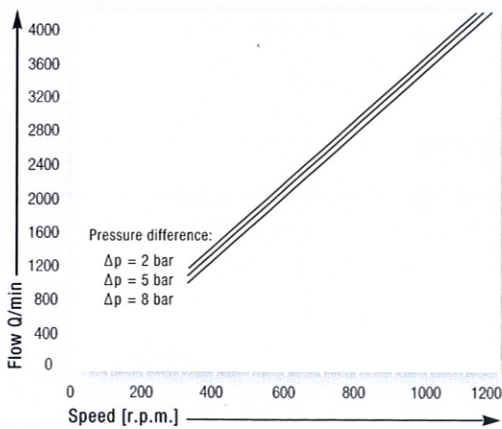

POWER CONSUMPTION

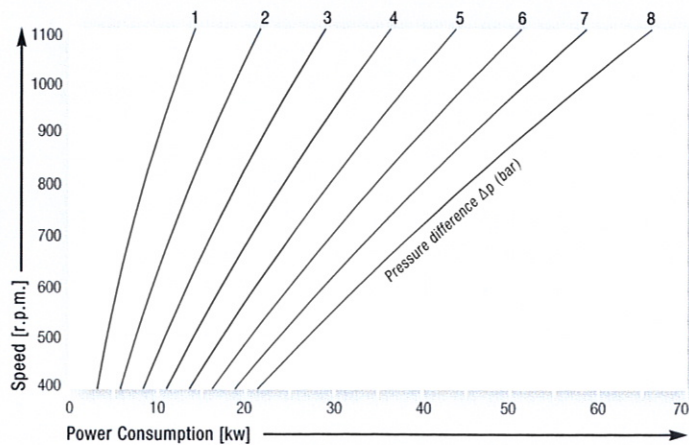

CSt for thin liquids with viscosities up to about 12cSt, such as Diesel and gasoline fuels.