

FPO 65

Tank truck vane pump



Self-priming vane pump

- depending on selected pump size up to 940 l/min with $\Delta p = 10$ bar

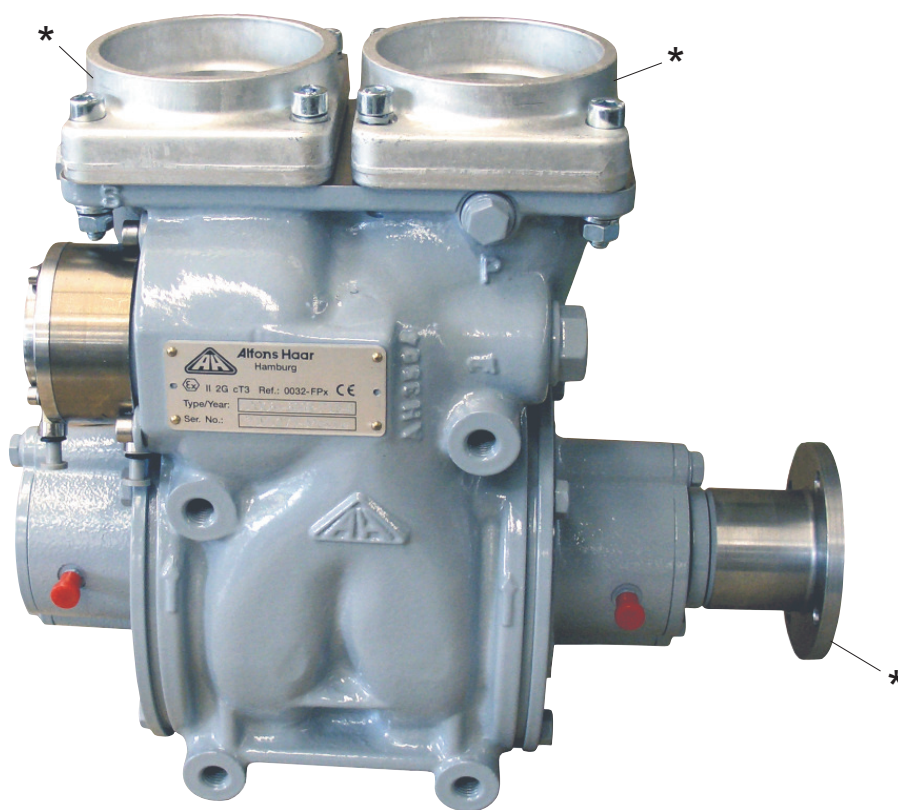

The Alfons Haar pump is Ex II 2G cT3 CE certified, an operating without a flame arrestor is possible !**

- computer optimized 3" to 2½" suction cross section for a quiet pump operation and high discharge rate
- large integrated pneumatic or mechanical by-pass valve
- ideal 3" and 2½" block flange for connection of the pipework to the pump in the tank truck
- very good blow down for product change
- excellent working life and simple service
- PTO or hydraulic drive

* accessories

** under compliance of the certified ATEX conditions

FPO 65

Tank truck vane pump



FPO... 65-289
-343
-407
-500
-600

Dimensions

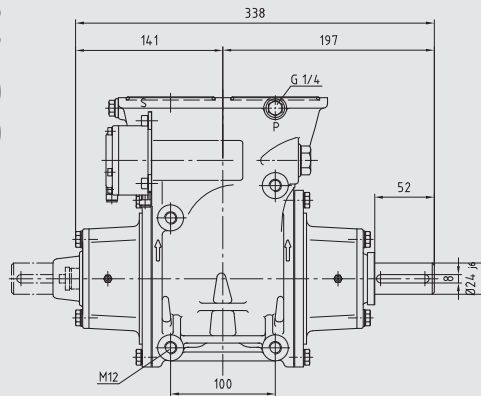

FPO G 65-

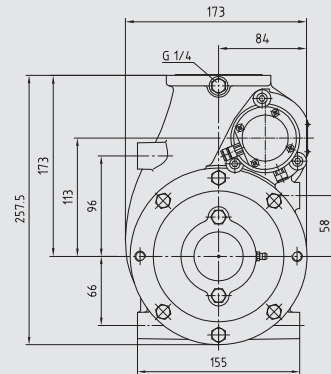

FPO S 65-

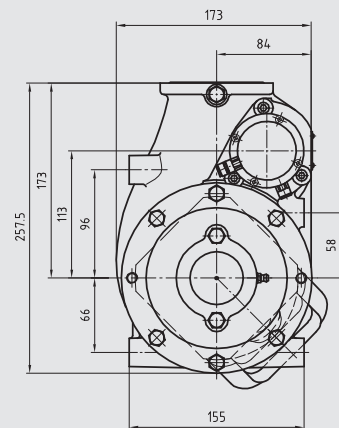
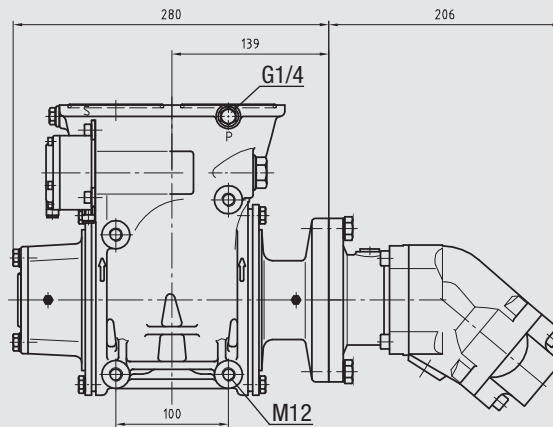

Flow rate at $\Delta p = 10$ bar

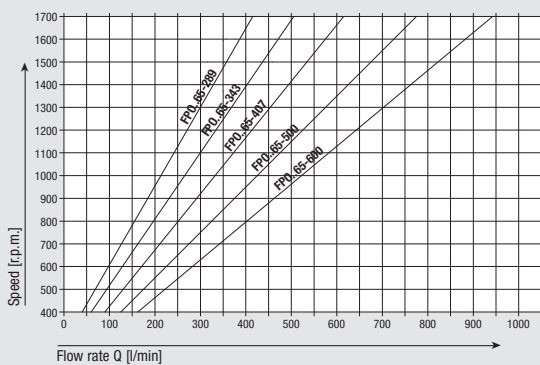

Input power at $\Delta p = 10$ bar

The input powers of the pump are minimum values for non-viscous media with viscosities up to approx. 12 cSt as e.g. heating oil EL, diesel and motor gasoline.

