



## DUAL FILTER HEAD

Item code: P568583

Donaldson Clean Solutions filter heads feature robust, aluminum construction with steel inserts to minimize metal-to-metal galling between the head and the filter, even when used with diesel fuel. Viton® seals are compatible with a wide range of fluids and maintain their integrity in cold weather.

For maximum cleanliness, use Clean Solutions filter heads with Clean Solutions filters.

*Viton® is a registered trademark of E.I. DuPont de Nemours and Company.*

### FEATURES:

- Steel inserts are safe to use with diesel fuel.
- Threads contain an O-ring to completely seal the clean side from the dirty side of the filter.
- Heads are pre-ported for optional pressure gauges and service indicators.

### APPLICATION:

- For use with Clean Solutions filters.
- Compatible with all diesel fuels and lubricants.

### SPECIFICATIONS:

- **Connection:** 11/2" SAE 4-Bolt Code 61 Flange
- **Filter Quantity:** 2 (sold separately)
- **Max. Flow Range:** 125gpm / 473Lpm
- **Fluid Compatibility:** All Diesel Fuels and Lubricants
- **Working Pressure:** 350 psi / 2413 kpa / 24.1 bar.
- **Rated Static Burst:** 800 psi / 5516 kpa / 55.2 bar.
- **Operating Temp.:** -40 to 245°F / -40 to 118°C
- **Materials:** Aluminium head with threaded steel inserts and Viton seals.
- **Compatible Filters:** DBB8664/5/6, DBB5333, DBB0248, DBB8777, DBB7733.
- **Indicator Port:** Use to adapt pressure gauges or sampling ports. (sold separately)

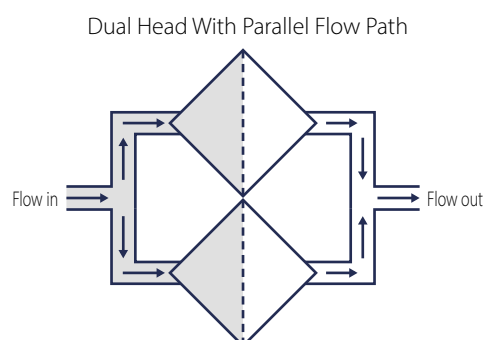

# PETRO INDUSTRIAL



petroind.com

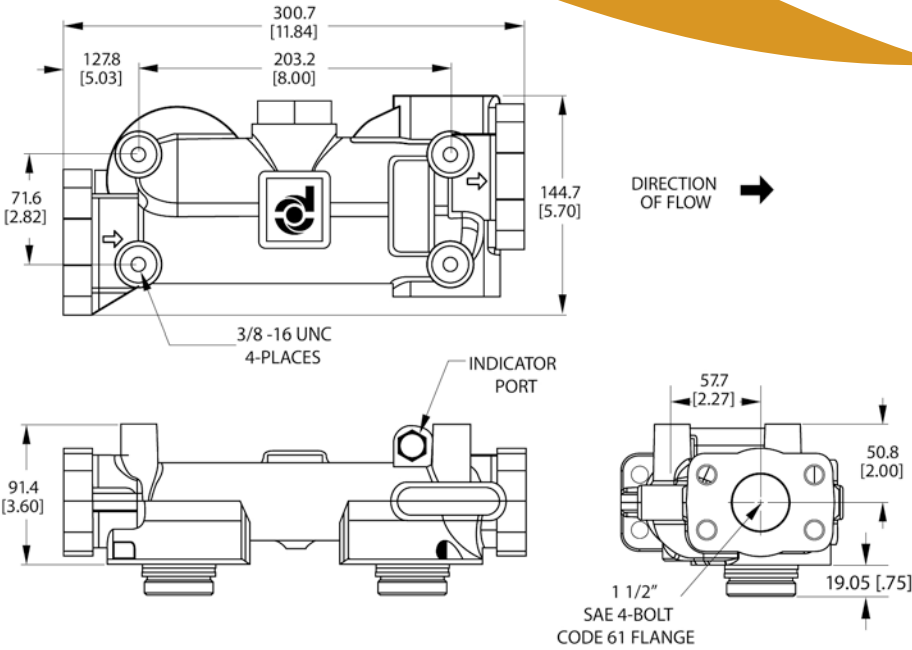

## ACHIEVING TARGET CLEANLINESS:

ISO 4406 contamination codes are a way to express fluid cleanliness. The three numbers correspond to the number of particles 4 microns and larger, 6 microns and larger, and 14 microns and larger present in the fluid. This illustrates what it means to start with a contamination of ISO 22/21/18 and target a cleanliness of ISO 14/13/11.

## WATER PROTECTION:

Are your bulk fluids passing large amounts of free water downstream – contaminating vehicles and equipment?

Donaldson's water absorbing filter with super absorbent polymer media, DBB0248, will stop flow if large amounts of free water are detected in your ethanol-free fluids. Designing systems with water absorbing filters requires careful sizing considerations. A specialist will assist in configuring a system that meets your specific needs for flow and pressure drop.

### RECOMMENDED ISO CLEANLINESS RATINGS:

