

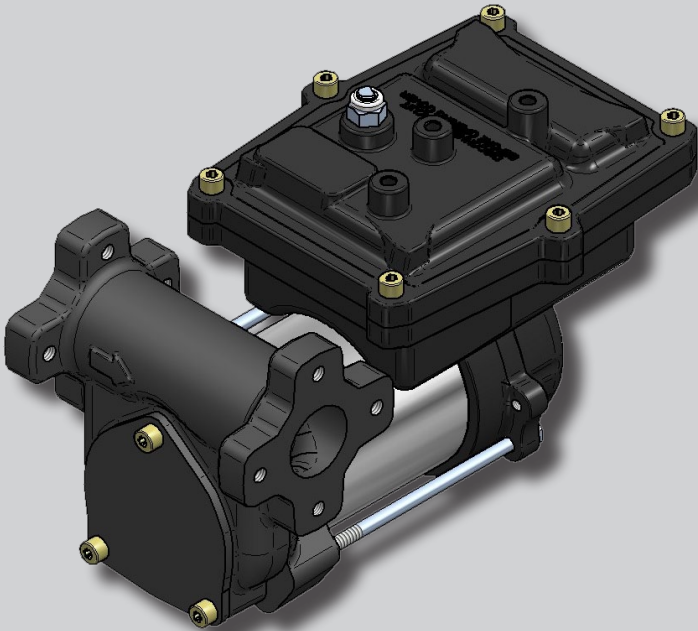

EX 50 12V



PIUSI
®

M0217ITEN rev 00

A TABLE OF CONTENTS

A	TABLE OF CONTENTS	19
B	MACHINE AND MANUFACTURER IDENTIFICATION	20
C	CONFORMITY	21
C1	DECLARATION OF CONFORMITY (94/9/CE, Annex X, lett. B)	21
C2	DECLARATION OF INCORPORATION OF PARTLY-COMPLETED MACHINERY	21
D	MACHINE DESCRIPTION	22
D1	DEFINITION OF CLASSIFIED ZONES	22
D2	INTENDED USE	23
D3	HANDLING AND TRANSPORT	23
E	GENERAL WARNINGS	24
F	FIRST AID RULES	24
G	GENERAL SAFETY RULES	25
H	TECHNICAL DATA	26
H1	PERFORMANCE SPECIFICATIONS	26
I	ELECTRICAL DATA	27
L	OPERATING CONDITIONS	27
L1	ENVIRONMENTAL CONDITIONS	27
L2	ELECTRICAL POWER SUPPLY	27
L3	DUTY CYCLE	28
L4	FLUIDS PERMITTED	28
M	INSTALLATION	28
M1	POSITIONING, CONFIGURATIONS AND ACCESSORIES	29
M2	NOTES ON SUCTION AND DELIVERY LINES	29
N	CONNECTIONS	30
N1	ELECTRICAL CONNECTIONS	30
N2	PIPING CONNECTIONS	31
O	INITIAL START-UP	31
P	EVERY DAY USE	32
Q	MAINTENANCE	32
R	NOISE LEVEL	33
S	PROBLEMS AND SOLUTIONS	33
T	DEMOLITION AND DISPOSAL	34
U	EXPLODED VIEWS	34

B MACHINE AND MANUFACTURER IDENTIFICATION

				 Suzzara (MN) Italy		ELECTRIC FUEL PUMP TYPE EX50 12V	
0722		II 2 G		Ex d II A T4 Gb		L.N. xxxxxxxxx	
○ CESI 12 ATEX 033X		IECEX CESI12.0000X		Date mm/yyyy		○	
12 V dc	17 A	2700 RPM	1/8 HP	T.amb. -10° / +40°C			
Insulation Class F		Duty min.30 ON 60 OFF		Q.max 52 l/m - Pmax 1,1 bar			
⚠ CAUTION: Automatic thermal protected motor - not open when energized							

AVAILABLE MODELS:
MANUFACTURER:

12V dc
PIUSI S.p.A.,
Via Pacinotti 16/A – z.i. Rangavino
46029 Suzzara - Mantova (Italy)

C CONFORMITY**C1 DECLARATION OF CONFORMITY (94/9/CE, Annex X, lett. B)**

The manufacturer: PIUSI S.p.A.
Via Pacinotti, 16/A
46029 Suzzara (MN) Italy

Declares under its own responsibility that the machine:

Type: Pump

Model: 12 V

Year of manufacture: refer to the year of production shown on the CE plate affixed to the product.

Tech. Ref. File Ad20_949.01.00

Notified body data: name, identification number and address

-1 Name: CESI S.p.A.

-2 Identification number: 0722

-3 Address: Via Rubattino, 134 - 20134 (Milano)

Number of the EC type-examination certificate: CESI 12 ATEX 033X

comply with all relevant provisions of the following directives:

- 94/9/CE

and the following harmonized standards, applied standards and/or technical specifications:

UNI EN 1127-1:2008; UNI EN 13463-1:2010;

CEI EN 60079-0:2009; CEI EN 60079-1:2007

This equipment is classified as follows:

Group II, category 2 G Ex d IIA T = 135° C (T4)

Read the Use and Maintenance manual before using the pump..

Place: Suzzara (Mn)

Date: 22/02/2012



Legal Representative

C2 DECLARATION OF INCORPORATION OF PARTLY-COMPLETED MACHINERY

The undersigned

PIUSI S.p.A

Via Pacinotti 16/A- z.i.Rangavino

46029 Suzzara - Mantova - Italy

HEREBY STATES under its own responsibility, that the partly-completed machinery:

Description: **Pump designed for the transfer of FUEL**

Model: **PUMP WITH ANTI-EXPLOSIVE HOUSING PROTECTION SYTEM**

Serial No.: refer to Lot Number shown on CE plate affixed to product

Year of manufacture: refer to the year of production shown on the CE plate affixed to the product.

Is intended to be incorporated in a machine (or to be with other machines) so as to create a machine to which applies Machine Directive 2006/42/EC, may not be brought into service before the machine into which it is to be incorporated has been declared in conformity with the provisions of the directive 2006/42/EC.

Is in conformity with the legal provisions indicated in the directives:

- Machine Directive 2006/42/EC

- Electromagnetic Compatibility Directive 2004/108/EC

To which the essential safety requirements have been applied and complied with

what indicated on annex I of the machine directive applicable to the product and shown below: 1.1.3 - 1.1.5 - 1.3.1 - 1.3.2 - 1.3.3 - 1.3.4 - 1.3.7 - 1.3.8 - 1.4.1 - 1.4.2.1 - 1.5.1 - 1.5.2 - 1.5.4 - 1.5.5 - 1.5.8 - 1.5.9 - 1.5.11 - 1.5.13 - 1.5.15 - 1.6.1 - 1.6.3 - 1.6.4 - 1.7.1 - 1.7.2 - 1.7.3 - 1.7.4.

The documentation is at the disposal of the competent authority following motivated request at Piusi S.p.A. or following request sent to the email address: doc_tec@piusi.com

The person authorised to compile the technical file and draw up the declaration is Otto Varini as legal representative.

Suzzara, 22/02/2012



Legal Representative

D MACHINE DESCRIPTION

PUMP	SELF-PRIMING, VOLUMETRIC, ROTATING ELECTRIC VANE PUMP, EQUIPPED WITH BY-PASS VALVE.
MOTOR	BRUSH MOTOR POWERED BY CONTINUOUS CURRENT, LOW VOLTAGE, WITH INTERMITTENT CYCLE, CLOSED TYPE, IP55 PROTECTION CLASS ACCORDING TO CEI EN 60034-5, FLANGE-MOUNTED DIRECTLY TO THE PUMP BODY.
ATTENTION	 <p>MOTOR EQUIPPED WITH AUTOMATIC THERMAL OVERLOAD PROTECTION. SHOULD THE PROTECTION ACTIVATE, TURN OFF THE PUMP AND WAIT FOR IT TO COOL DOWN.</p>

D1 DEFINITION OF CLASSIFIED ZONES

FOREWORD	Definition of zones as shown in UNI EN 1127-1 standard
ZONE 0	Place where an explosive atmosphere made up of a mix of air and inflammable substances in the form of gas, vapour or mist is continuously present, either for long periods or frequently. Note: Generally speaking, said conditions, when they occur, involve the inside of tanks, pipes and containers, etc.
ZONE 1	Place where it is probable that an explosive atmosphere, made up of a mix of air and inflammable substances in the form of gas, vapour or mist, can occur occasionally during normal operation. Note: Said zone can also include: - places in the immediate vicinity of zone 0; - places in the immediate vicinity of supply openings; - places in the immediate vicinity of filling and emptying openings; - places in the immediate vicinity of appliances, protection systems and fragile glass and ceramic components, or components made of other similar materials; - places in the immediate vicinity of inadequately sealed stuffing boxes, e.g., on pumps and valves with stuffing box.
ZONE 2	Place where it is improbable that an explosive atmosphere, made up of a mix of air and inflammable substances in the form of gas, vapour or mist, can occur during normal operation, but which, if it does occur, only persists for a short time. Note: Said zone can include, among others, places surrounding the zones 0 or 1.
ZONE 20	Place where an explosive atmosphere in the form of a cloud of combustible powders in the air is continuously present, either for long periods or frequently. Note: Generally speaking, said conditions, when they occur, involve the inside of tanks, pipes and containers, etc.
ZONE 21	Place where it is probable that an explosive atmosphere, in the form of a cloud of combustible powders in the air, can occur occasionally during normal operation. Note: Said zone can include, for example, among others, places in the immediate vicinity of powder loading and emptying points and places where powder layers form or which, during normal operation, could produce an explosive concentration of combustible powders mixed with the air.
ZONE 22	Place where it is improbable that an explosive atmosphere, in the form of a cloud of combustible powders in the air, occur during normal operation but which, if it does occur, only persists for a short time. Note: This zone can comprise, among others, places near appliances, protection systems and components containing powder, out of which the powder can come out due to leaks with the formation of powder deposits (e.g., milling salt, where the powder comes out of the mills and deposits).

D2 INTENDED USE**INTENDED USE**

PUMP FOR TRANSFERRING FUEL SUITABLE FOR OPERATING IN ZONES CLASSIFIED "1" AND "2", ACCORDING TO DIRECTIVE 94/9/CE

FORBIDDEN USE

Using the appliance for fluids other than those listed at paragraph "L4 – Fluids permitted" and for uses other than those described at the item "authorised use" is forbidden.

PLANT OPERATION RESTRICTIONS**IT IS FORBIDDEN:**

- 1 To use the appliance in a construction configuration other than that contemplated by the manufacturer
- 2 To use the appliance with fixed guards tampered with or removed.
- 3 To use the appliance in places where there is risk of explosion and/or fires classified in the following zones: 0; 20; 21; 22
- 4 To integrate other systems and/or equipment not considered by the manufacturer in the executive project.
- 5 To connect the appliance up to energy sources other than those contemplated by the manufacturer
- 6 To use the commercial devices for purposes other than those indicated by the manufacturer.

D3 HANDLING AND TRANSPORT

Due to the limited weight and dimensions of the pumps, special lifting equipment is not required to handle them. The pumps are carefully packed before dispatch. Check the packing when receiving the material and store in a dry place.

E GENERAL WARNINGS

Important precautions

To ensure operator safety and to protect the pump from potential damage, workers must be fully acquainted with this instruction manual before performing any operation.

Symbols used in the manual

The following symbols will be used throughout the manual to highlight safety information and precautions of particular importance:



ATTENTION

This symbol indicates safe working practices for operators and/or potentially exposed persons.



WARNING

This symbol indicates that there is risk of damage to the equipment and/or its components.



NOTE

This symbol indicates useful information.



ATTENTION

Important note for guaranteed safety in classified zones

Manual preservation

This manual should be complete and legible throughout. It should remain available to end users and specialist installation and maintenance technicians for consultation at any time.

Reproduction rights

All reproduction rights are reserved by Piusi S.p.A. The text cannot be reprinted without the written permission of Piusi S.p.A.

© Piusi S.p.A.

THIS MANUAL IS THE PROPERTY OF Piusi S.p.A.
ANY REPRODUCTION, EVEN PARTIAL, IS FORBIDDEN.

NOTE



THIS MANUAL IS VALID ONLY FOR DC PUMPS

ALWAYS USE THE RIGHT VOLTAGES TO CONNECT THE PUMPS

ATTENTION



PUMP CANNOT BE USED FOR REFUELLING AIRCRAFTS SUPPLIED BY AVGAS

ATTENTION



USE THE PUMP ONLY WITH FLUIDS PERMITTED. DO NOT USE WITH FLUIDS NOT PERMITTED TO AVOID DAMAGING THE PUMP. THE GUARANTEE LAPSES IN CASE OF MISUSE OF THE FLUID.

DO NOT USE THE PUMP WITH LIQUID FOOD PRODUCTS AND/OR WATER-BASED FLUIDS.

DO NOT OPERATE THE PUMP DRY TO AVOID DAMAGE.

Before connection, make sure that the piping and the suction tank are free of dirt and solid residue that could damage the pump and its accessories. NEVER COLLECT THE FLUID FROM THE BOTTOM OF THE TANK SINCE IT MAY CONTAIN IMPURITIES



BEFORE USING THE PUMP SWITCH OFF ALL THE ELECTRONIC DEVICES (I.E. MOBILE PHONES, BEEPERS ETC.)

F FIRST AID RULES

Contact with the product

In the event of problems developing following EYE/SKIN CONTACT, INHALATION or INGESTION of the treated product, please refer to the SAFETY DATA SHEET of the fluid handled.

Persons who have suffered electric shock

Disconnect the power source, or use a dry insulator to protect yourself while you move the injured person away from any electrical conductor. Avoid touching the injured person with your bare hands until he is far away from any conductor. Immediately call for help from qualified and trained personnel. Do not operate switches with wet hands.

NOTE

















Please refer to the safety data sheet for the product

SMOKING PROHIBITED



DO NOT SMOKE NEAR THE PUMP AND DO NOT USE THE PUMP NEAR FLAMES.

G GENERAL SAFETY RULES

USER'S RESPONSIBILITY		IT IS ESSENTIAL TO GET TO KNOW AND UNDERSTAND THE INFORMATION CONTAINED IN THIS MANUAL.
Essential protective equipment characteristics		IT IS ESSENTIAL TO GET TO KNOW AND OBSERVE THE SAFETY SPECIFICATIONS FOR FLAMMABLE LIQUIDS.
Personal protective equipment that must be worn	BEFORE USING THE PUMP IT'S IMPORTANT TO TRAIN OPERATORS, INSTALLERS AND MAINTENANCE STAFF TO LET THEM WORK IN A PARTICULAR AREA NO. 1 AS MENTIONED BY DIRECTIVE 94/9/EC	IN CASE OF CONTACT WITH THE PRODUCT AND FOR GOOD STANDARD OF BEHAVIOUR, wear protective equipment which is: <ul style="list-style-type: none"> • suited to the operations that need to be performed; • resistant to products used TO DO SO, PLEASE REFER TO THE RELEVANT TECHNICAL DATASHEETS OF THE FLUID USED.
		safety shoes
		close-fitting clothing
Necessary safety devices		protection gloves
		safety goggles
Necessary safety devices		instructions manual
Protective gloves		Prolonged contact with the treated product may cause skin irritation; always wear protective gloves during dispensing.
NOTE		TO PREVENT ELECTRIC SHOCK AND DETONATION OF SPARKS, ALL PUMPING SYSTEM MUST HAVE PROPER GROUNDING, INCLUDING TANK AND ANY ACCESSORIES.
DANGER		ENFORCE REGULATIONS FOR ELECTRICAL INSTALLATION ALL WIRING AND ELECTRICAL CONNECTIONS MUST BE PERFORMED BY AUTHORIZED AND SUITABLY TRAINED PERSONNEL.
	Never touch the electric plug or socket with wet hands. Do not switch the dispensing system on if the network connection cable or important parts of the apparatus are damaged, such as the inlet/outlet pipe, nozzle or safety devices. Replace the damaged pipe immediately.	
ATTENTION		The electrical connection between the plug and socket must be kept well away from water.
ATTENTION NOTE		THE PUMP IS EQUIPPED WITH CURRENT-SENSING PROTECTION. IF IT ACTIVATES TURN OFF THE PUMP IMMEDIATELY.
		THE PUMP IS EQUIPPED WITH PROTECTION AGAINST OVERHEATING AND OVERLOAD RISKS. SHOULD SUCH DEVICES ACTIVATE, THE PUMP SHUTS DOWN AUTOMATICALLY, BUT THE MASTER SWITCH IS NOT TURNED OFF. IT IS IMPORTANT TO STOP THE PUMP USING ITS SWITCH. THE PUMP RESTARTS AFTER ITS NORMAL OPERATING CONDITIONS HAVE BEEN RESTORED.
ATTENTION		FAILURE TO OBSERVE THE ABOVE MENTIONED RULES CAN CAUSE SERIOUS ACCIDENTS
ATTENTION		SHOULD THE HEAT SENSOR ACTIVATE UNDER NORMAL USE CONDITIONS, PLEASE CONTACT THE TECHNICAL SUPPORT.

H1 PERFORMANCE SPECIFICATIONS

The performance diagram shows flow rate as a function of back pressure.

Functioning Point	Absorption(A)	Flow Rate (l/min)	Back Pressure (BAR)	Typical delivery configuration	
				4 meters of 3/4" tube	automatic dispensing nozzle
A (Maximum Flow Rate)	15	52	0,2		
B (Base system)	17	40	0,5	•	•
C (By-Pass)	24	0	1,1	Delivery Closed	

ATTENTION



The curve refers to the following operating conditions:

Fluid: PETROL,

Temperature: 20° C

Suction conditions: The pipe and the pump position relative to the fluid level is such that a low pressure of 0.3 bar is generated at the nominal flow rate.

Under different suction conditions higher low pressure values can be created that reduce the flow rate compared to the same back pressure values. To obtain the best performance, it is very important to reduce loss of suction pressure as much as possible by following these instructions:

- shorten the suction pipe as much as possible
- avoid useless elbows or throttling in the pipes
- keep the suction filter clean
- use a pipe with a diameter equal to, or greater than, indicated (see Installation).

I ELECTRICAL DATA

PUMP MODEL	POWER SUPPLY		CURRENT
	Voltage (V)	Frequency (Hz)	Max (*) (A)
12V	12	DC	25

(*) Refers to functioning in by-pass mode.

POWER CORD INLET 1/2" NPT

L OPERATING CONDITIONS

L1 ENVIRONMENTAL CONDITIONS

AMBIENT TEMPERATURE	min. +23 °F / max +104 °F min. -10 °C / max +40 °C
FLUID TEMPERATURE	min. +23 °F / max +104 °F min. -10 °C / max +40 °C
RELATIVE HUMIDITY	max. 90%
LIGHTING	The environment must conform to directive 89/654/EEC on work environments. In case of non-EU countries, refer to directive EN ISO 12100-2 § 4.8.6.

ATTENTION



The temperature limits shown apply to the pump components and must be respected to avoid possible damage or malfunction.

L2 ELECTRICAL POWER SUPPLY

NOTE



The pump must be powered by DC line, the nominal values of which are indicated on the table in the paragraph "I - ELECTRICAL DATA".
The maximum acceptable variations from the electrical parameters are:
Voltage: +/- 5% of the nominal value

ATTENTION



Power supply from lines with values that do not fall within the indicated limits could cause damage to the ELECTRICAL AND electronic components.

L3 DUTY CYCLE

NOTE



The pumps have been designed for intermittent use and a duty cycle of 30 min. ON and 60 min. OFF in conditions of maximum A. TEMPERATURE (40 °C) AND AT NOMINAL TRANSFER CONDITIONS.

ATTENTION



Functioning under by-pass conditions is only allowed for short periods of time (max. 3 minutes).

L.4 FLUIDS PERMITTED

ATTENTION



THE PUMP CAN BE USED ONLY WITH THE FOLLOWING FLUIDS:
 - DIESEL - KEROSENE
 - PETROL - PETROL ALCOHOL MIXED MAX 15%

M INSTALLATION

ATTENTION



BEFORE ANY OPERATION, ENSURE TO BE OUT OF POTENTIALLY EXPLOSIVE AREAS



The pump must never be operated before the delivery and suction lines have been connected.

TIGHTEN THE ELECTRICAL BOX TO ENSURE PROTECTION AGAINST THE RISK OF EXPLOSION THE RIGHT CLAMPING SCREWS COUPLE THAT GRANTS THIS PROTECTION IS 10Nm

PRELIMINARY INSPECTION

- Verify that all components are present. Request any missing parts from the manufacturer.
- Check that the pump has not suffered any damage during transport or storage.
- Carefully clean the suction and delivery inlets and outlets, removing any dust or other packaging material that may be present.
- Check that the electrical data corresponds to those indicated on the data plate.
- Install the pump at a height of min. 80 cm.

ATTENTION



IF VALVES IN THE CIRCUIT ARE TO BE INSTALLED, MAKE SURE THEY ARE EQUIPPED WITH OVERPRESSURE SYSTEM. CLEAN THE TANK AND MAKE SURE IT IS WELL-VENTILATED (RECOMMENDED OPENING PRESSURE: 3 psi)



APPLY THE QUICK COUPLING TO THE TANK CORRECTLY AND SAFELY

ATTENTION



DO NOT BLOCK THE DRAINAGE HOLES

M1 POSITIONING, CONFIGURATIONS AND ACCESSORIES

NOTE

The pump must be secured in a stable manner.

ATTENTION

It is the installer's responsibility to provide the line accessories necessary for the safe and proper functioning of the pump. The accessories that are not suitable to be used with the previously indicated material could damage the pump and/or cause injury to persons, as well as causing pollution. To maximise performance and prevent damage that could affect pump operation, always demand original accessories.

M2 NOTES ON SUCTION AND DELIVERY LINES

DELIVERY

The selection of the pump model must be made taking into account the characteristics of the system.

The combination OF: the length of the pipe, the diameter of the pipe, as well as the accessories installed, could create back pressure that are greater than the maximum predicted pressure, thereby causing the pump's electronic controls to intervene and reducing the dispensed flow considerably.

In these cases, to guarantee correct operation of the pump, it is necessary to reduce the resistance of the system using pipes that are shorter or that have a greater diameter, as well as line accessories with smaller resistances (e.g. an automatic dispensing nozzle with greater flow rate capacity).

SUCTION**FOREWORD**

Self-priming pumps are characterized by excellent suction capacity.

During the start-up phase, when the suction pipe is empty and the pump is wet with the fluid, the electric pump unit is able to suck liquid from a maximum vertical distance of 2m.

It is important to note that it could take up to 1 minute for the pump to prime and that the presence of an automatic dispensing nozzle on the delivery side will prevent the air trapped during the installation from being released and, therefore, the correct priming of the pump. For this reason, it is always advisable to prime the pump without an automatic delivery nozzle, verifying the proper wetting of the pump.

Always install a foot valve to prevent the suction pipe from being emptied and to keep the pump wet at all times. In this way, the pump will always start up immediately the next times it is used. When the system is in operation, the pump can operate with back pressures of up to 0.5 bars on the suction inlet; beyond this point, the pump may begin to cavitate resulting in a drop of the flow rate and an increase in the noise levels of the system.

In light of this, it is important to guarantee small back pressures on the suction side, by using short pipes with diameters that are equal to or larger than those recommended, reducing bends to a minimum, and using filters with a large cross-section and foot valves with minimum possible resistance on the suction side. It is very important to keep the suction filters clean because, when they become clogged, they increase the resistance of the system.

The vertical distance between the pump and the fluid must be kept as short as possible, and it must fall within the 2m maximum required for priming. If the distance is greater, a foot valve must be installed to allow the suction pipes to fill up and the diameter pipes must be larger. It is however recommended that pump not be installed if the vertical distance is greater than 3m.

ATTENTION

If the suction tank is higher than the pump, an anti-siphon valve should be installed to prevent accidental diesel fuel leaks. Dimension the installation in order to control the back pressures due to water hammering

It is a good system practice to install vacuum and air pressure gauges right at the inlets and outlets of the pump, which allow verification that operating conditions are within anticipated limits. To prevent the suction pipes from being emptied when the pump stops, a foot valve should be installed.

THE INSTALLER IS RECOMMENDED TO INSTALL A SUCTION FILTER.

N1 ELECTRICAL CONNECTIONS

ATTENTION



BEFORE ANY OPERATION, ENSURE TO BE OUT OF POTENTIALLY EXPLOSIVE AREAS



IT IS THE INSTALLER'S RESPONSIBILITY TO CARRY OUT THE ELECTRICAL CONNECTIONS IN COMPLIANCE WITH THE RELEVANT STANDARDS.

WARNING



Comply with the following (not exhaustive) instructions to ensure a proper electrical connection:

- During installation and maintenance make sure that power supply to the electric lines has been turned off.
- Use cables with minimum sections, rated voltages and installation type that are suitable for the characteristics indicated in paragraph "I - ELECTRICAL DATA" and the installation environment.
- Always make sure that the cover of the terminal strip box is closed before switching on the power supply, after having checked the integrity of the seal gaskets that ensure the IP55 protection grade. For those screws use a 10 nm clamping couple

ATTENTION



All motors are equipped with a grounding terminal. Make sure all the plant is properly grounded.

ATTENTION



BE SURE TO USE A CABLE GLAND, WITH SUFFICIENT PROTECTION GRADE (Exd)

NOTE



IN THE EVENT OF INSTALLATION IN ZONES WHICH ARE NOT CLASSIFIED, IT IS SUFFICIENT TO OBSERVE THE MINIMUM SAFETY STANDARDS ALREADY MENTIONED IN THIS MANUAL.

- THE OWNER HAS THE RESPONSIBILITY TO VERIFY THAT ALL THE LOCAL AND NATIONAL REGULATIONS HAVE BEEN OBSERVED.
- MAKE SURE THAT THE CABLE CONNECTING THE BATTERY IS PROTECTED FROM HEAT SOURCES AND SHARP EDGES. INSTALL THE FUSE CLOSER TO THE BATTERY.

ATTENTION



FAILURE TO OBSERVE THE ABOVE MENTIONED RULES CAN CAUSE SERIOUS ACCIDENTS

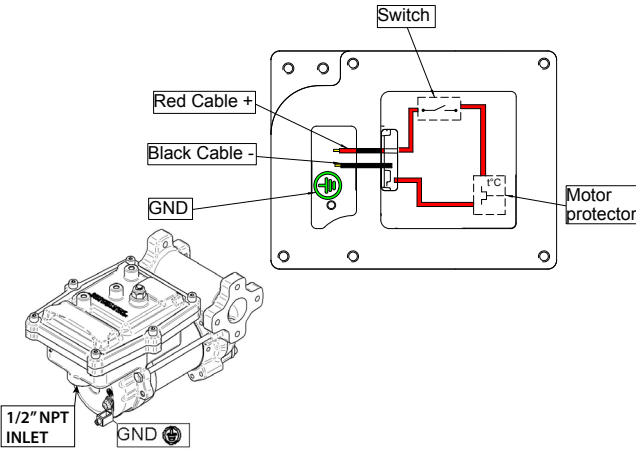

N2 PIPING CONNECTIONS

FOREWORD - Before carrying out any connection, refer to the visual indications i.e. arrow on the pump head, to identify suction and delivery.

ATTENTION  **Wrong connection can cause serious pump damage.**

PRELIMINARY INSPECTION

- Before connection, make sure that the piping and the suction tank are free of dirt and solid residue that could damage the pump and its accessories. NEVER COLLECT THE FLUID FROM THE BOTTOM OF THE TANK SINCE IT MAY CONTAIN IMPURITIES
- Before connecting the delivery pipe, partially fill the pump body, from delivery side, with the liquid that needs to be pumped in order to facilitate priming.
- Do not use conical threaded fittings, which could damage the threaded inlet or outlet openings of the pump if excessively tightened.

O INITIAL START-UP

FOREWORD

- Check that the quantity of fluid in the suction tank is greater than the amount you wish to transfer.
- Make sure that the residual capacity of the delivery tank is greater than the quantity you wish to transfer.
- Make sure that the piping and line accessories are in good condition.

NOTE  **THIS PUMP IS NOT PROVIDED FOR FURTHER REGULATION OF DELIVERY AND PRESSURE**

ATTENTION  **Fluid leaks can damage objects and injure persons.**

NOTE 

- Never start or stop the pump by connecting or cutting out the power supply.
- Prolonged contact with some fluids can damage the skin. The use of goggles and gloves is recommended.

IF THE PUMP DOES NOT PRIME

Depending on the system characteristics, the priming phase can last from several seconds to a few minutes. If this phase is prolonged, stop the pump and verify:

- that the pump is not running completely dry (fill with fluid from the delivery line);
- that the suction pipe guarantees against air infiltration;
- that the suction filter is not clogged;
- that the suction height is not higher than 2 mt.
- that all air has been released from the delivery pipe.

AT THE END OF THE INITIAL START-UP

When priming has occurred, verify that the pump is operating within the anticipated range, in particular:

- that under conditions of maximum back pressure, the power absorption of the motor stays within the values shown on the identification plate;
- that the delivery back pressure does not exceed the maximum back pressure for the pump.

P EVERY DAY USE

- USE PROCEDURE**
- 1 If flexible pipes are used, attach the ends of the piping to the tanks. In the absence of an appropriate slot, solidly grasp the delivery pipe before beginning dispensing.
 - 2 Before starting the pump make sure that the delivery valve is closed (dispensing nozzle or line valve)
 - 3 Turn the ON/OFF switch on
 - 4 Open the delivery valve, solidly grasping the pipe
 - 5 While dispensing, do not inhale the pumped product
 - 6 IF ANY TREATED FLUID LEAKS OUT DURING DISPENSING, TAKE ALL STEPS NECESSARY TO ENSURE THE LEAKED FLUID IS CLEANED UP AND SAFE AS SPECIFIED ON THE PRODUCT TECHNICAL SHEET.
 - 7 Close the delivery valve to stop dispensing
 - 8 When dispensing is finished, turn off the pump

ATTENTION



THE WORKING OPERATIONS MUST ALWAYS BE GUARDED BY THE OPERATOR.

The by-pass valve allows functioning with delivery closed only for short periods (max. 3 minutes).

To avoid damaging the pump, after use, make sure the pump is off.

In case of a power break, switch the pump off straight away.

Should any sealants be used on the suction and delivery circuit of the pump, make sure that these products are not released inside the pump.

Foreign bodies in the suction and delivery circuit of the pump could cause malfunctioning and breakage of the pump components.

Q MAINTENANCE

- Safety instructions**
- The PUMP IS DESIGNED AND CONSTRUCTED TO require a minimum of maintenance.
 Before carrying out any maintenance work, DISCONNECT THE PUMP from any electrical and hydraulic power source.
 During maintenance, the use of personal protective equipment (PPE) is compulsory.
 In any case always bear in mind the following basic recommendations for a good functioning of the pump

ATTENTION



BEFORE ANY OPERATION, ENSURE TO BE OUT OF POTENTIALLY EXPLOSIVE AREAS FOR SAFETY REASONS IT'S NOT ALLOWED TO DISASSEMBLE THESE PARTS : (1) BOTTOM (2) MOTOR PIPE (3) PUMP BODY

- Authorised maintenance personnel**
- All maintenance must be performed by qualified personnel. Tampering can lead to performance degradation, danger to persons and/or property and may result in the warranty and UL/ATEX CERTIFICATION being voided.

- Measures to be taken**
- Check that the labels and plates found on the dispensing system do not deteriorate or become detached over time.

- ONCE A WEEK:**
- Check that the pipe connections are not loose to prevent any leaks;
 - Check and keep the filter installed on the suction line clean.

- ONCE A MONTH:**
- Check the pump body and keep it clean and free of any impurities;
 - Check that the electrical supply cables are in good condition.

R NOISE LEVEL

Under normal operating conditions, noise emission of all models does not exceed 74 dB at a distance of 1 metre from the electric pump.

S PROBLEMS AND SOLUTIONS

For any problems contact the authorised dealer nearest to you.

PROBLEM	POSSIBLE CAUSE	CORRECTIVE ACTION
THE MOTOR IS NOT TURNING	Lack of electric power	Check the electrical connections and the safety systems.
	Rotor jammed	Check for possible damage or obstruction of the rotating components.
	Motor problems	Contact the Service Department
THE MOTOR TURNS SLOWLY WHEN STARTING	Low voltage in the electric power line	Bring the voltage back within the anticipated limits
LOW OR NO FLOW RATE	Low level in the suction tank	Refill the tank
	Foot valve blocked	Clean and/or replace the valve
	Filter clogged	Clean the filter
	Excessive suction pressure	Lower the pump with respect to the level of the tank or increase the cross-section of the piping
	High loss of head in the delivery circuit (working with the by-pass open)	Use shorter piping or of greater diameter
	By-pass valve blocked	Dismantle the valve, clean and/or replace it
	Air entering the pump or the suction piping	Check the seals of the connections
	A narrowing in the suction piping	Use piping suitable for working under suction pressure
	Low rotation speed	Check the voltage at the pump. Adjust the voltage and/or use cables of greater cross-section
The suction piping is resting on the bottom of the tank	Raise the piping	
INCREASED PUMP NOISE	Cavitation occurring	Reduce suction pressure
	Irregular functioning of the by-pass	Dispense until the air is purged from the by-pass system
LEAKAGE FROM THE PUMP BODY	Presence of air in the fluid	Verify the suction connections
THE PUMP DOES NOT PRIME THE LIQUID	Seal damaged	Check and replace the seal
	Suction circuit blocked	Remove the blockage from the suction circuit
	Malfunction of foot valve fitted on suction circuit	Replace foot valve
	The suction chambers are dry	Add liquid from pump delivery side
THE HEAT SENSOR ACTIVATES UNDER NORMAL OPERATING CONDITIONS	The pump chambers are dirty or blocked	Remove the blockages from the suction and delivery valves
	Operating fault	Contact the technical support.

T DEMOLITION AND DISPOSAL

Foreword If the system needs to be disposed, the parts which make it up must be delivered to companies that specialize in the recycling and disposal of industrial waste and, in particular:

Disposal of packing material The packaging consists of biodegradable cardboard which can be delivered to companies for normal recycling of cellulose.

Disposal of metal parts Metal parts, whether paint-finished or in stainless steel, can be consigned to scrap metal collectors.

Disposal of electric and electronic components These must be disposed of by companies that specialize in the disposal of electronic components, in accordance with the indications of directive 2002/96/CE (see text of directive below).



Information regarding the environment for clients residing within the European Union

European Directive 2002/96/EC requires that all equipment marked with this symbol on the product and/or packaging not be disposed of together with non-differentiated urban waste. The symbol indicates that this product must not be disposed of together with normal household waste. It is the responsibility of the owner to dispose of these products as well as other electric or electronic equipment by means of the specific refuse collection structures indicated by the government or the local governing authorities.

Disposal of miscellaneous parts Other components, such as pipes, rubber gaskets, plastic parts and wires, must be disposed of by companies specialising in the disposal of industrial waste.

U EXPLODED VIEWS

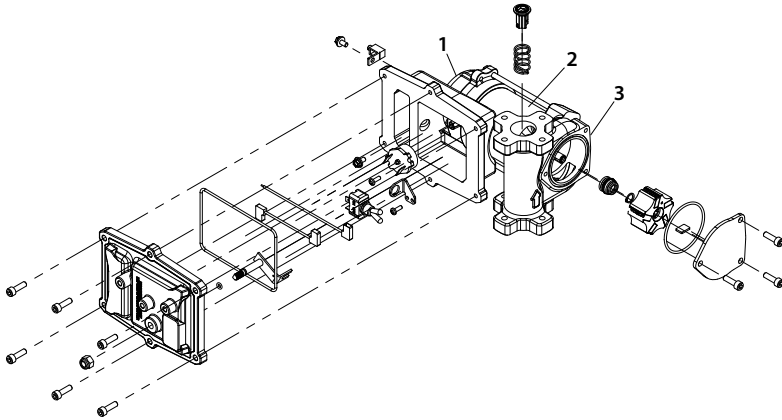



Piusi S.p.A
46029 Suzzara (Mantova) Italy
www.piusi.com

The Company reserves the right to modify the information contained in this user manual without any prior notice

M0217ITEN rev 00