

LED Lighting Fixture

SAVE THESE INSTRUCTIONS



BEFORE YOU BEGIN

Read and follow all safety instructions

WARNING

RISK OF FIRE, EXPLOSION AND ELECTRIC SHOCK

- This product should be installed, inspected, and maintained by a qualified electrician only, in accordance with the NEC (National Electric Code) and all local codes.
- Turn off electrical power before inspection, installation or removal.
- Use only UL (or other NRTL) approved wire for input/output connections.
- Minimum size 18 AWG or 14 AWG for continuous runs.
- Make sure LEDs and drivers are cool to touch when performing maintenance.
- Make sure the supply voltage is the same as the rated voltage of the luminaire.
- Do not install in a hazardous atmosphere, except where the ambient temperature does not exceed the rated operating temperature of the fixture.
- Keep tightly closed when in operation

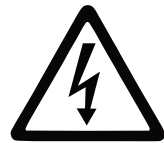

Prepare Electrical Wiring



Electrical Requirements

- The LED driver must be supplied with 120 to 277V, 50/60 Hz and connected to an individual, properly grounded branch circuit protected by a 20 ampere circuit breaker. Use min. 75°C supply.



Grounding Instructions

- The grounding and bonding of the overall system shall be done in accordance with NEC Article 600 and local codes

LED Lighting Fixture

Installation Guide

Tools Required:

Phillips Screw Driver
Security Torx T- 20 Bit and Driver
Electric Drill
Drill Bit Set
Wire Strippers
Wire Cutters

- Before starting ensure that the power is disconnected.
- Unpack fixture and ensure that there are no damaged parts.
- NOTE: This fixture is intended to be surface mounted on to a wall in the lens down position.
- Open fixture by removing the T-20 Security Torx screws on the side of the fixture.
- Remove LED and Frame assembly to allow for easier installation.
- Inspect the 3 mounting hole locations. (they are item A on fig. 2) and ensure that there are no components over them.
- In order to mount the fixture the backplate has to be pierced at the mounting locations. Use an appropriate sized drill bit for the mounting screws up to 5/16".
- Align the backplate and mount securely.
- To secure it correctly, use sealant or silicone gel to prevent moisture from entering the drilled holes.
- If the electrical connections are going to be made from a conduit pipe remove one of the conduit plugs from the base and thread NPS conduit pipe into location.
- If electrical connections are going to be made through a junction box drill the appropriate holes (Item C in Fig. 1) for the sized junction box.
- Splice power connections as seen in Fig. 3.
- Reattach Frame and Glass assembly to base by slipping it over the barrel pins.
- Reconnect driver and LED connections and reattached the Frame assembly using the Torx Screw.

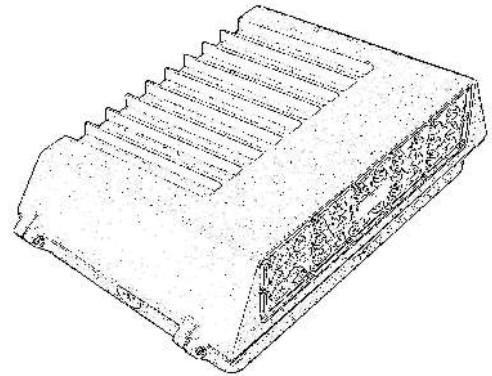

Figure 1.

MOUNTING:

The back plate has a cast-in drill and knock-out template to match any standard recessed junction box, three 5/16" knock-outs for mounting holes A and three 1/2" NPS tapped holes D for surface conduit or photocontrol unit.

- A – 5/16" dia. Knockouts
- B – 9/16" dia. Knockouts.
- C – Knockouts for #10 screw.
- D – 1/2" NPS tapped holes.

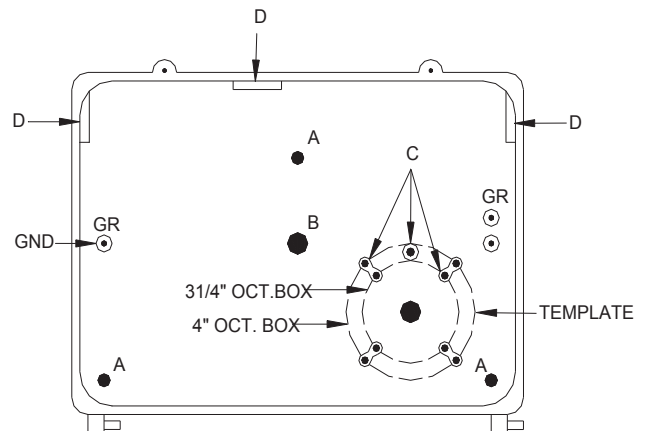

Figure 2.