

LED Lighting Fixture

SAVE THESE INSTRUCTIONS



BEFORE YOU BEGIN

Read and follow all safety instructions

WARNING

RISK OF FIRE, EXPLOSION AND ELECTRIC SHOCK

- This product should be installed, inspected, and maintained by a qualified electrician only, in accordance with the NEC (National Electric Code) and all local codes.
- Turn off electrical power before inspection, installation or removal.
- Use only UL (or other NRTL) approved wire for input/output connections. Minimum size 18 AWG or 14 AWG for continuous runs.
- Make sure LEDs and drivers are cool to touch when performing maintenance. Make sure the supply voltage is the same as the rated voltage of the luminaire.
- Do not install in a hazardous atmosphere, except where the ambient temperature does not exceed the rated operating temperature of the fixture.
- Keep tightly closed when in operation



Prepare Electrical Wiring



Electrical Requirements

- The LED driver must be supplied with 120 to 277V, 50/60 Hz (or 347 to 480V, 50/60 Hz, when applicable - refer to product label) and connected to an individual, properly grounded branch circuit protected by a 20 Ampere circuit breaker. Use min. 75°C supply.



Grounding Instructions

- The grounding and bonding of the overall system shall be done in accordance with NEC Article 600 and local codes

LED FLOOD LIGHT

Installation Guide

Tools and Materials Required:

- 1/8" Hex Key
- Wire Strippers
- Wire Cutters
- Silicone caulk
- Drill with assorted bits
- Mounting Hardware

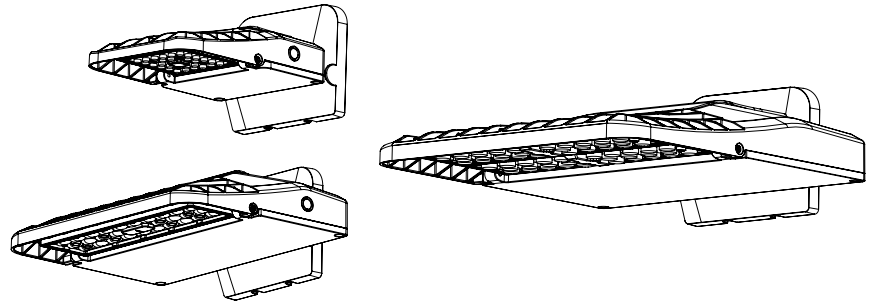

Before starting:

- Ensure that the supply power is shut off.
- Unpack the fixture and ensure that there are no damaged or missing parts

Installation Steps (without Emergency Backup):

- 1a) Remove the quick mount bracket from the fixture base by loosening the two set screws
- 2a) Install the quick mount bracket on a junction box in the desired location using hardware appropriate for the mounting surface (provided by others).
- 3a) Attach the aircraft cable hook from the fixture base to a secure point in the junction box (or mounting surface).
- 4a) Connect the fixture power leads to the supply leads using the included wire nuts (see wiring diagram).
- 5a) Detach the aircraft cable hook from the junction box (or mounting surface).
- 6a) Attach the fixture base back to the quick mount bracket by hooking the top of the bracket into the angled bracket on the back side of the fixture base. Then lower the fixture until flush with the quick mount bracket and wall.
- 7a) Secure the quick mount bracket to the fixture base by tightening the two set screws.
- 8a) Apply silicone caulking around the fixture base for water-proofing, including the area around the set screws.

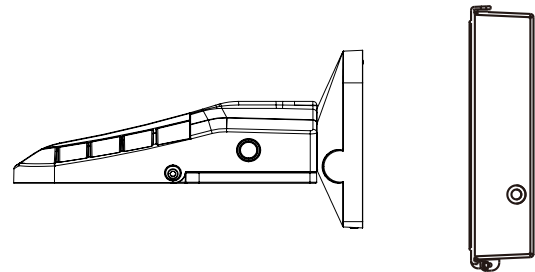
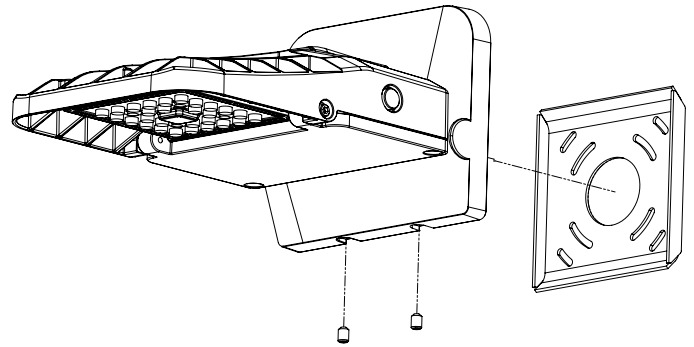

Installation Steps (with Emergency Backup):

- 1b) Install the EB-001 Emergency Backup box to the surface according to the EB-001 installation instructions.
- 2b) Apply silicone caulking on the mounting surface around the EB-001 to seal the area behind the box.
- 3b) Follow Steps 1a - 3a above to attach the quick mount bracket to the front cover of the EB-001.
- 4b) Drill a hole for the wiring pass-through in the front cover of the EB-001 center of the quick mount bracket.
- 5b) Connect the appropriate fixture leads to the emergency backup system according to the emergency backup wiring diagram (provided with the EB-001).
- 6b) Follow steps 5a - 8a to complete the installation.
- 7b) Apply silicone caulking to the front cover screw of the the EB-001 for water-proofing.

Standard Wiring Diagram



LED FLOOD LIGHT

Installation Guide

Installation Steps (Thru-wiring):

- 1c) Remove the quick mount bracket from the fixture base by loosening the two set screws
- 2c) Install the thru-wiring junction box in the desired location using hardware appropriate for the mounting surface (provided by others).
- 3c) Attach the aircraft cable hook from the fixture base to a secure point in the junction box.
- 4c) Connect the fixture power leads to the supply leads using the included wire nuts (see wiring diagram).
- 5c) Detach the aircraft cable hook from the junction box (or mounting surface).
- 6c) Attach the fixture base back to the thru-wiring junction box by hooking the top of the box into the angled bracket on the back side of the fixture base. Then lower the fixture until flush with the thru-wiring junction box and wall.
- 7c) Secure the thru-wiring junction box to the fixture base by tightening the two set screws.
- 8c) Apply silicone caulking around the fixture base and thru-wiring junction box for water-proofing, including the area around the set screws.
- 9c) Remove the 1/2" conduit plugs on sides of the junction box to install conduit for thru-wiring. Use thread sealant for water-proofing.

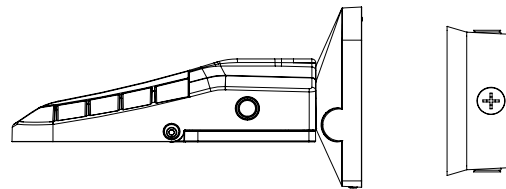
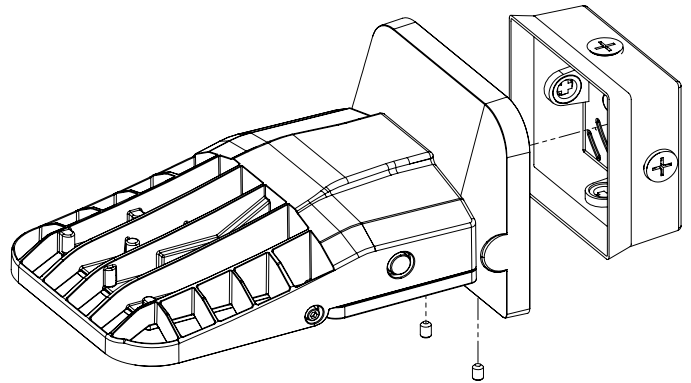

Standard Wiring Diagram

