

ML-GC-5968

LED Canopy Light

DESCRIPTION

This canopy light has a slim and low profile design which provides safe and a visually appealing lighting experience. Luminaire can be mounted directly or with 3/4" pendant mounting option. Quick mount structure for contractors to work safely and easily in the confined-space areas. It is a perfect solution to replace 1 DOW metal halide lamp with a benefit of low maintenance cost.



Specification Features



Construction

► Industrial grade die-cast aluminum alloy body is tough on the elements and allow the luminaire to withstand the harshest of conditions.

Optical System

► Next generation LEDs combined with the best-in-class UV stablized commercial grade polycarbonate lens provide the most efficient lighting system. Optical system is engineered to provide professional grade light distribution and uniformity.

Electrical

► Long lasting LED coupled with UL Listed Drivers provide an electrical system that will stand the test of time. Universal voltage allow the luminaire to be used in multi-faceted environments

Finish

► Luminaire is electrostatically coated with UV stabilized powder coat providing years of worry-free service.

Certification

► cUL and UL Listed. Listed for Wet Locations. DLC Premium certified.

Ordering information

Model No.	System Watts	Input Voltage	CRI	Color Temp	Lumen Output	MA	Starting Temp
ML-GC-5968-82W-5K-UV	82W	120-277V	70+	5000 K	10093 lm**	2000 MA	-40°C

* DISCLAIMER: This test report was produced in accordance with IES LM-79 photometric testing protocol for luminaires, using a single representative test fixture. Actual production units may vary from the values reported here by up to ±10%.

Line Drawing

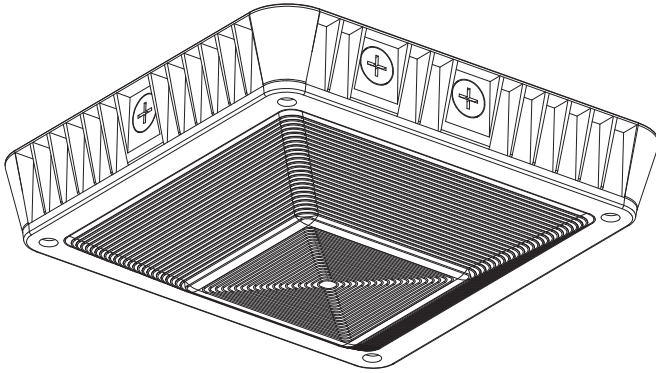

Product Dimensions

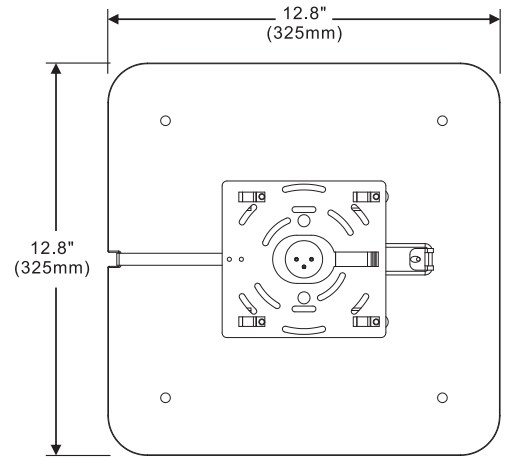

Available Mounting Options



Optional photo control



Quick mount

