

# Installation and operation guide for

**DIAGNOSTICPRO™ Advantage**



**DOSIMETRYPRO™ Advantage**



**CADPRO™ Advantage**

with 50 sheet SmartFeeder™  
and 100 sheet SmartFeeder™

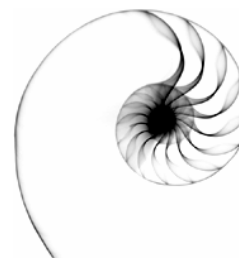

---

**Serial Numbers 300000 to 339999**

# Bayland

baylandtechnologies.com  
telephone: 1-800-801-8432

# Warranty information

for VIDAR film digitizers



365 Herndon Parkway

Herndon, VA 20170 USA

Phone: 1-703-471-7070 • Fax: 1-703-471-7665

E-mail: medtech@vidar.com

Instructions:

1. Cut along dotted line at left.
2. Fill in.
3. Make a copy for your records.
4. E-mail or fax to VIDAR.

Date \_\_\_\_\_

## System integrator information

### System integrator administrative contact

Name	Title
Company name	Telephone no.
E-mail address	Fax no.

### System integrator technical contact

Name	Title
Company name	Telephone no.
E-mail address	Fax no.

### Shipping information

Company name		
Street address		
City	State	Postal code
Country	Telephone no.	Fax no.

## Product information

What product are you registering? (Select only one)

- VXR-12 Plus       TeleradPRO       SIERRA:       SIERRA *plus*:  
 DiagnosticPRO       Single film feeder       Single film feeder  
 DiagnosticPRO *plus*       Multi-film feeder       Multi-film feeder

What is the product's serial number? \_\_\_\_\_

What is the SCSI ID? \_\_\_\_\_ How is the SCSI termination set? On Off

Where is this film digitizer installed? (Or where will it be installed?)

- Hospital       Office  
 Clinic       Other \_\_\_\_\_

Why did you purchase this product? (Select all that apply and rate importance)

Feature	Not important					Important				
<input type="checkbox"/> Price	1	2	3	4	5	1	2	3	4	5
<input type="checkbox"/> Performance	1	2	3	4	5	1	2	3	4	5
<input type="checkbox"/> Style	1	2	3	4	5	1	2	3	4	5
<input type="checkbox"/> Reliability	1	2	3	4	5	1	2	3	4	5
<input type="checkbox"/> Size	1	2	3	4	5	1	2	3	4	5
<input type="checkbox"/> Maintenance record	1	2	3	4	5	1	2	3	4	5
<input type="checkbox"/> Image quality	1	2	3	4	5	1	2	3	4	5
<input type="checkbox"/> Packaging	1	2	3	4	5	1	2	3	4	5
<input type="checkbox"/> Documentation	1	2	3	4	5	1	2	3	4	5
<input type="checkbox"/> Software (TWAIN)	1	2	3	4	5	1	2	3	4	5
<input type="checkbox"/> Multi-sheet capability	1	2	3	4	5	1	2	3	4	5
<input type="checkbox"/> Service and support	1	2	3	4	5	1	2	3	4	5
<input type="checkbox"/> Other _____	1	2	3	4	5	1	2	3	4	5

## End user information

### End user administrative contact

Name	Title
Company name	Telephone no.
E-mail address	Fax no.

### End user technical contact

Name	Title
Company name	Telephone no.
E-mail address	Fax no.







**Bayland**

baylandtechnologies.com  
telephone: 1-800-801-8432

Part Number: 16667-004 REV A

April, 2005

Printed in the USA.

© Copyright 2005 by VIDAR Systems Corporation. All rights reserved.

No part of this publication may be reproduced, stored in a retrieval system, or transmitted, in any form or by any means, electronic, mechanical, photocopying, recording or otherwise, without the prior written permission of VIDAR Systems Corporation.

Terms denoted by the trademark symbol (™ or ®) used in this publication are trademarks or service marks registered in the United States or other countries.

## NOTE

The VIDAR digitizers are used to digitize radiographs (X-ray film) or other transparent targets. When the digitizer is used to digitize radiographic films, the digital image is intended for use in primary, secondary and over reading applications.

The digitizers do not include application specific software (Picture Archiving and Communications [PAC] system, Teleradiology, Oncology Systems, or Computer Aided Detection [CAD] software). The manufacturer of the application software will determine specific indications for use. These third-party software packages or complete systems are approved separately from a regulatory perspective.

The digitizers are marketed as a component to application software development companies, who will incorporate the digitizer into their respective PACS or Teleradiology, CAD system(s). The software developer is ultimately responsible for detailing the Contradictions for the PACS System (or Teleradiology software package) or Oncology Systems as a whole, including the digitizer.

**Caution:** No operator-serviceable parts inside. Refer servicing to qualified personnel.

**Achtung:** Gehäuse nicht öffnen. Wartung und reparatur nur durch eletrofachkräfte.

**Attention:** Aucune piece ne peut etre remplacee par l'utilisateur. Toute operation de maintenance doit etre effectuee par une personne qualiee.

**Atencion:** Acceso interno solo autorizado a personal tecnico cualificado.

**Attenzione:** Non aprire. Rivolgarsi a personale qualificado.



365 Herndon Parkway  
Herndon, VA 20170 U.S.A.

**Phone:** +1.703.471.7070  
**Fax:** +1.703.471.7665  
**Internet:** www.filmdigitizer.com

**Sales:** +1.800.471.SCAN or +1.800.471.7226  
Email: sales@vidar.com

**Technical Support:**  
+1.703.471.7070 or +1.800.471.7226  
E-mail: medtech@vidar.com

Authorized representative  
in Europe

**Emergo Europe**  
P.O. Box 149  
4300 AC Zierikzee  
The Netherlands

**Phone:** (31) 1114 11515  
**Fax:** (31) 1114 10104  
**Email:** info@emergogroup.com

## Radio Frequency Emissions

This equipment has been tested and found to comply with the limits for a Class A digital device, pursuant to Part 15 of the FCC Rules. These limits are designed to provide reasonable protection against harmful interference when the equipment is operated in a commercial environment. This equipment generates, uses, and can radiate radio frequency energy and, if not installed and used in accordance with the instruction manual, may cause harmful interference to radio communications. Operation of this equipment in a residential area can cause harmful interference, in which case the user will be required to correct the interference at his or her own expense.

Product compliance testing was conducted using VIDAR shielded cables. Modifications to the digitizer or the VIDAR shielded cables or the use of cables other than those available from VIDAR could void the user's authority to operate the equipment.

## CE Declarations

VIDAR Systems Corporation declares the product is classified as a Class I medical device per Annex IX, Rule 10 and are in conformity with the essential requirements and provisions of Council Directive 93/42/EEC and conforms to standards; EN60601-1: 1998 with Amendments 1 and 2, UL60601-1(2003), CAN/CSA C22.2 NO.601.1-M90 with Amendments 1 and 2.

This device is classified as a Group 1 Class A device for Electro Magnetic Compatibility per EN55011:1998. This device complies with standards: EN55011, EN60601-1-2: 2001 (EN61000-3-2: 1995 with Amendments A1, 2 and 14, EN61000-3-3:1995, EN61000-4-2:1995 with Amendments 1 and 2, EN61000-4-3:1997 with Amendment 1, EN61000-4-4:1995 with Amendments 1 and 2, EN61000-4-5:1995 with Amendment 1, EN61000-4-6:1996 with Amendment 1, EN61000-4-8:1993, EN61000-4-11 with Amendment 1).

## FDA (501)k Certification

CADPRO™ Advantage: 993598

DIAGNOSTICPRO™ Advantage and DOSIMETRYPRO™ Advantage: 993599

---

### Acceptable shipping conditions

- Temperature: -25° to +65°C (-13° to +150°F)
- Relative humidity: 10% to 95%, non-condensing
- Atmos. pressure: 500 to 1060hPa (+18,000 to -1,200ft)

### Operating conditions

- Temperature: 10°C to 35°C (50°F to 100°F)
- Relative humidity: 20% to 80%, non-condensing
- Atmos. pressure: 697 to 1060hPa (10,000 to -1,200ft)

---

**Electrical supply** Voltage: 100 to 240 VAC    Current: 1.5 to 0.75 A    Frequency: 47 to 63 Hz

## Safety and compliance information



5RA9

MEDICAL EQUIPMENT WITH RESPECT TO ELECTRIC SHOCK, FIRE AND MECHANICAL HAZARDS ONLY IN ACCORDANCE WITH UL60601-1, IEC60601-1 AND CAN/CSA C22.2 No. 601.1

DIAGNOSTICPRO™ Advantage, DOSIMETRYPRO™ Advantage and CADPRO™ Advantage carry the CE mark, issued by BSI

This product's function and intended use is as an X-ray Film Digitizer.

To maintain Medical Equipment Certification, the digitizer must be connected to a host computer that has been configured in accordance with IEC 60601-1-1.

This product is in the Ordinary Equipment Class. It provides no protection against the ingress of water.

This product is not suitable for use in the presence of flammable anesthetic mixtures with air or with oxygen or with nitrous oxide.

Class I Medical Device; No Applied Parts. This product provides Class I medical device protection against electrical shock.

Power cords used with this device in North America must be rated by Underwriters Laboratories for hospital use. Power cords used with this device in Europe must meet the requirements of IEC 227 Designation 53 or IEC 245 Designation 53.

The use of portable or mobile communications equipment and/or the presence of strong electromagnetic and/or x-ray fields may interfere with proper operation of this product. This product should not be used adjacent to or stacked with other equipment. If adjacent or stacked use is necessary, verify normal operation in the configuration in which it will be used. Should such interference occur, the user is required to provide adequate isolation between the digitizer and the source of the interference. Isolation is typically achieved by moving the digitizer away from the source of the interference.

This product is intended to be turned on and left on. Operation is continuous.

Correct and safe operation of the digitizer requires familiarity with information that is not marked on the product. The following symbol indicates the operator should consult the manual for additional information.



Turn off the scanner before mounting or removing the feeder. Mount the feeder to the scanner by mating the connector found on the bottom of the feeder to the connector found on the top of the scanner. Secure the feeder to the scanner with the three thumbscrews. To remove the feeder, reverse the mounting process.

# Contents

---

<b>DIAGNOSTICPRO™ Advantage and DOSIMETRYPRO™ Advantage Installation Guide.....</b>	<b>7</b>
<b>Unpacking.....</b>	<b>8</b>
1. Look for damage .....	8
2. Unpack the shipping carton.....	9
3. Unpack the accessory box.....	10
4. Unwrap.....	12
5. Identify the components.....	13
6. If anything is missing.....	14
7. Activate your product warranty.....	14
<b>Setting up.....</b>	<b>15</b>
Identify important features.....	16
Assemble the digitizer .....	17
Connect the power cord.....	23
Where to go from here.....	24
<b>CADPRO™ Advantage Installation Guide .....</b>	<b>25</b>
<b>Unpacking.....</b>	<b>26</b>
1. Look for damage .....	26
2. Unpack the shipping carton.....	27
3. Unpack the accessory box.....	28
4. Unwrap.....	30
5. Identify the components.....	32
6. If anything is missing.....	33
7. Activate your product warranty.....	33
<b>Setting up.....</b>	<b>34</b>
Identify important features.....	35
Assemble the digitizer .....	36
Connect the power cord.....	40
Where to go from here.....	41
<b>Interfacing Guide .....</b>	<b>43</b>

---

# VIDAR Drivers and Toolkit Installation CD and Driver Information..... Tab 4

VIDAR device driver summary.....	45
About the STI drivers .....	45
<b>SCSI settings .....</b>	<b>47</b>
If necessary, set the digitizer's SCSI ID .....	48
If necessary, terminate the SCSI bus.....	49
Connect the SCSI cable to the digitizer .....	50
<b>Installing SCSI hardware .....</b>	<b>51</b>
1. Install the SCSI card. ....	53
2. Configure the SCSI BIOS .....	55
<b>Installing SCSI drivers .....</b>	<b>59</b>
<b>Installing USB drivers .....</b>	<b>67</b>
USB interface requirements.....	67
Updating a previous VIDAR STI driver installation .....	68
Installing the USB drivers.....	69
<b>Updating the VIDAR Toolkit.....</b>	<b>79</b>
<hr/>	
<b>Advantage Series Operating Guide .....</b>	<b>83</b>
operating <b>DIAGNOSTICPRO™ Advantage and DOSIMETRYPRO™ Advantage</b> .....	<b>84</b>
About digitizers and film sizes.....	84
About films .....	86
Basic operating instructions .....	87
Digitizing a single film.....	88
Digitizing multiple films.....	90
operating <b>CADPRO™ Advantage</b> .....	<b>93</b>
Film sizes and scanning specifications.....	93
About films .....	94
Operating instructions .....	95
<hr/>	
<b>Advantage Series Other Information.....</b>	<b>97</b>
<b>Preventive maintenance .....</b>	<b>98</b>
Cleaning the Auto-Feed Roller [DIAGNOSTICPRO™ Advantage and DOSIMETRYPRO™ Advantage only].....	98

Cleaning the Auto-Feed Roller and Suction Cups [CADPRO™ Advantage only] .....	99
Cleaning the diffuser [all Advantage models].....	102
Replacing the lamp cartridge [all Advantage models].....	106
<b>Troubleshooting .....</b>	<b>107</b>
Reading the LEDs.....	107
In case of difficulty.....	111
<b>Weights and dimensions.....</b>	<b>114</b>
<b>SCSI information and troubleshooting guide .....</b>	<b>115</b>
Introduction .....	115
Digitizer and SCSI controller compatibility .....	115
SCSI cable .....	116
Troubleshooting.....	117
<b>Packing the film digitizer for shipment.....</b>	<b>120</b>
1. Turn off the digitizer.....	120
2. Disconnect the power cord and SCSI or USB cable.....	121
3. Remove the exit tray from the digitizer base .....	122
4. Remove the feeder from the digitizer base.....	123
5. Remove the digitizer base from the stand [DIAGNOSTICPRO™ Advantage and DOSIMETRYPRO™ Advantage only] .....	124
6. Prepare the feeder [CADPRO™ Advantage only] .....	125
7. Wrap certain items .....	126
8. Pack the accessory box.....	127
9. Pack the shipping carton.....	131
<b>Electromagnetic guidance .....</b>	<b>137</b>

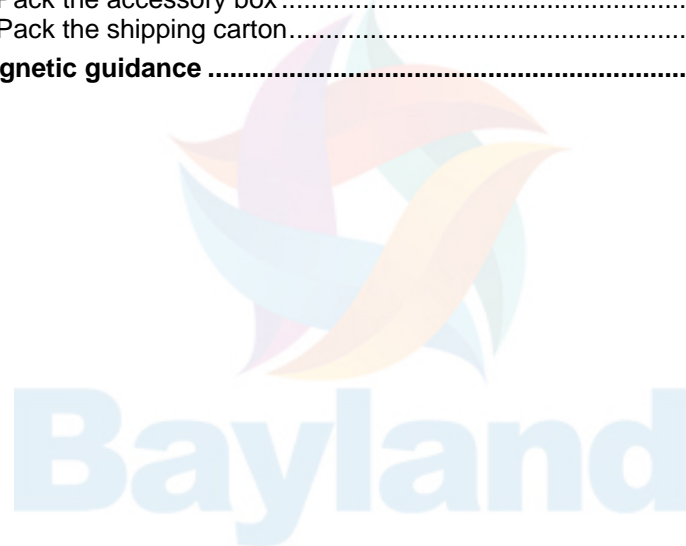



DIAGNOSTICPRO™ Advantage  
and  
DOSIMETRYPRO™ Advantage  
Installation Guide

baylandtechnologies.com  
telephone: 1-800-801-8432

**VIDAR**  
systems corporation  
Medical Imaging



# Unpacking

---

## 1. Look for damage

Before unpacking the film digitizer, examine the shipping carton for damage.

If the carton is damaged, notify the shipper immediately.

**IMPORTANT:** Save the carton and all packing materials. If you need to ship the digitizer later, you **must** repack it using the original wire ties, plastic bags, foam supports and cartons. Instructions for repacking are provided in “Appendix: Packing the film digitizer for shipment.”



## 2. Unpack the shipping carton

Remove items from the shipping carton in the order shown below.

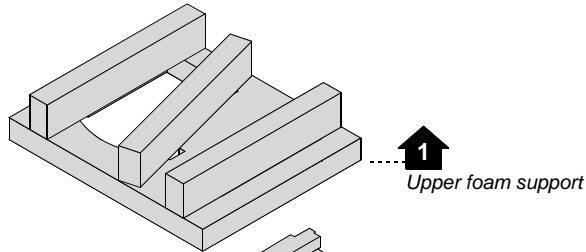

**Note:** For clarity, this illustration does not show the plastic bags surrounding the digitizer and feeder.

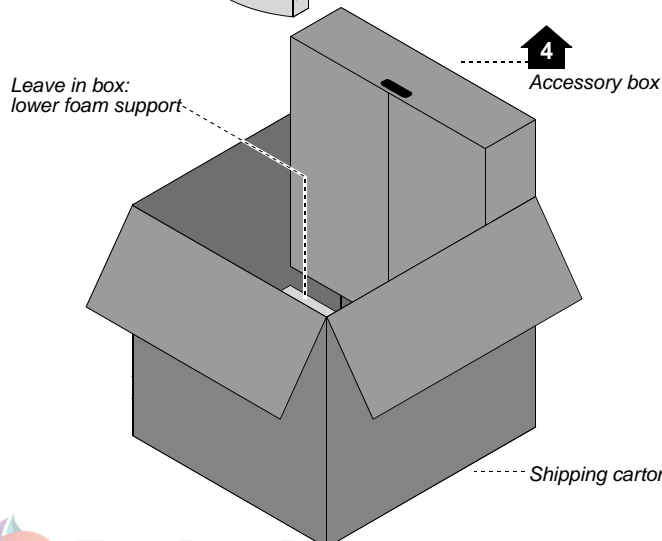
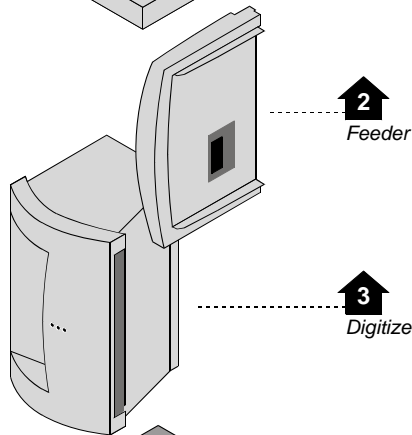

**Bayland**  
technologies

baylandtechnologies.com  
telephone: 1-800-801-8432

### 3. Unpack the accessory box

a. Remove these items from the accessory box:

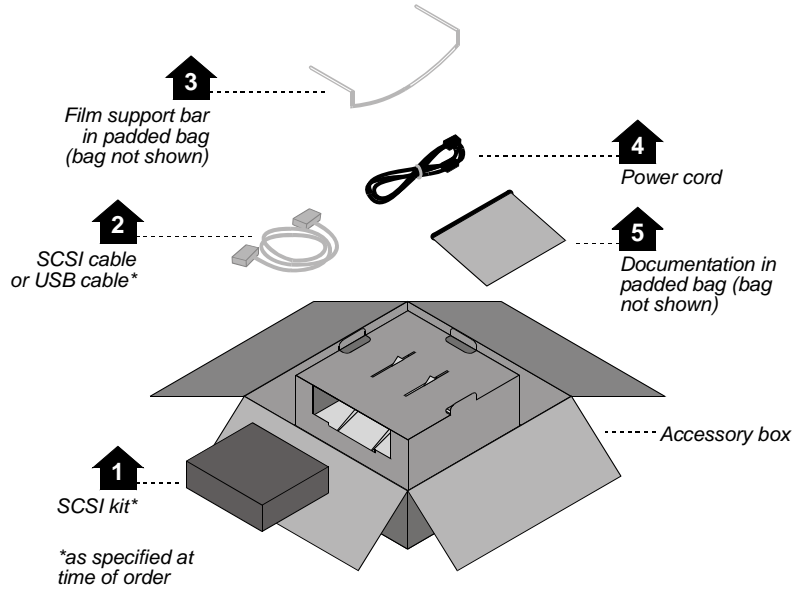

b. Then remove these items from the accessory box:

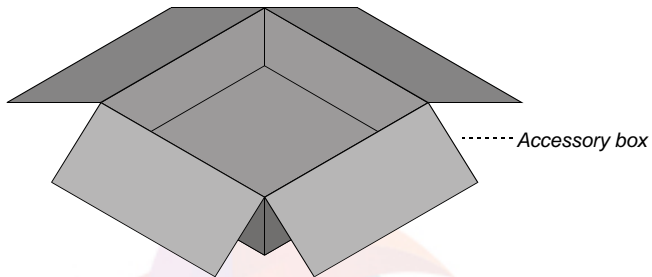
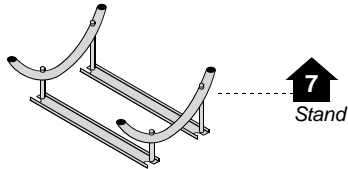
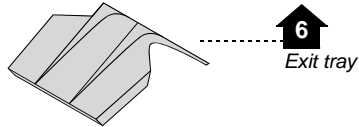
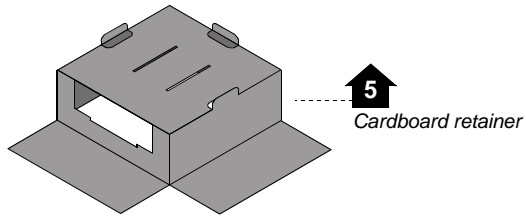

**Note:** For clarity, this illustration does not show the plastic bag surrounding the exit tray.



Bayland

## 4. Unwrap

- a. Unwrap all items.
- b. Remove the foam block from the rear of the digitizer base:

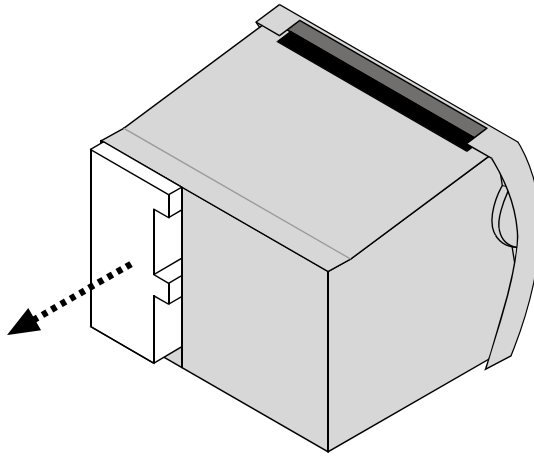

**IMPORTANT:** Save the carton and all packing materials. If you need to ship the digitizer later, you **must** repack it using the original wire ties, plastic bags, foam supports and cartons. Instructions for repacking are provided in "Appendix: Packing the film digitizer for shipment."



## 5. Identify the components

- | ✓                        | Item  |
|--------------------------|---|
| <input type="checkbox"/> | Digitizer base  |
| <input type="checkbox"/> | Exit tray   |
| <input type="checkbox"/> | Film feeder   |
| <input type="checkbox"/> | Film support bar  |
| <input type="checkbox"/> | Stand   |
| <input type="checkbox"/> | Power cord: 115V (p/n 4043-001) <b>or</b> 230V (p/n 2104-006) |
| <input type="checkbox"/> | <i>Important Safety Information card</i> (on film feeder)     |
| <input type="checkbox"/> | <i>Quick setup card</i>                                       |



Digitizer base



Film feeder



Film support bar



Stand



Exit tray

- |                          |   |
|--------------------------|---|
| ✓                        | <b>Other items*</b> (see footnote)  |
| <input type="checkbox"/> | Adaptec 2930 SCSI kit (p/n 3053) and SCSI cable: 6 foot MMD-50 to SCSI III 68-pin male (p/n 4270) |
| <input type="checkbox"/> | USB cable: 6 foot (p/n 4618)  |

\*You will receive either a SCSI kit and SCSI cable **or** a USB cable, as specified at time of order.

## 6. If anything is missing...

Immediately contact your VIDAR supplier.

## 7. Activate your product warranty

Complete the warranty information/customer survey form at the back of this manual and mail it to VIDAR Systems Corp.

If your digitizer needs service, this information should be on file at VIDAR.

**Contact VIDAR Technical Support** if you have any questions about installing or using your VIDAR film digitizer:

Phone: +1.800.471.SCAN (+1.800.471.7226)

+1.703.471.7070 outside the U.S.

E-mail: [medtech@vidar.com](mailto:medtech@vidar.com)

---

**NEXT:** Go to “Setting up” ➡

---

The logo for Bayland Technologies, featuring a stylized, multi-colored circular emblem composed of overlapping leaf-like shapes in shades of purple, blue, orange, and yellow. Below the emblem, the word "Bayland" is written in a large, light blue, sans-serif font.

Bayland

# Setting up

The digitizer must be placed on a counter or tabletop.

## SAFETY WARNING

Never place the digitizer on the floor.



**Bayland**  
technologies

baylandtechnologies.com  
telephone: 1-800-801-8432



## Identify important features

Look over the digitizer base and locate the features shown in this section. You will need to know where these features are when you assemble and operate the digitizer in later chapters.

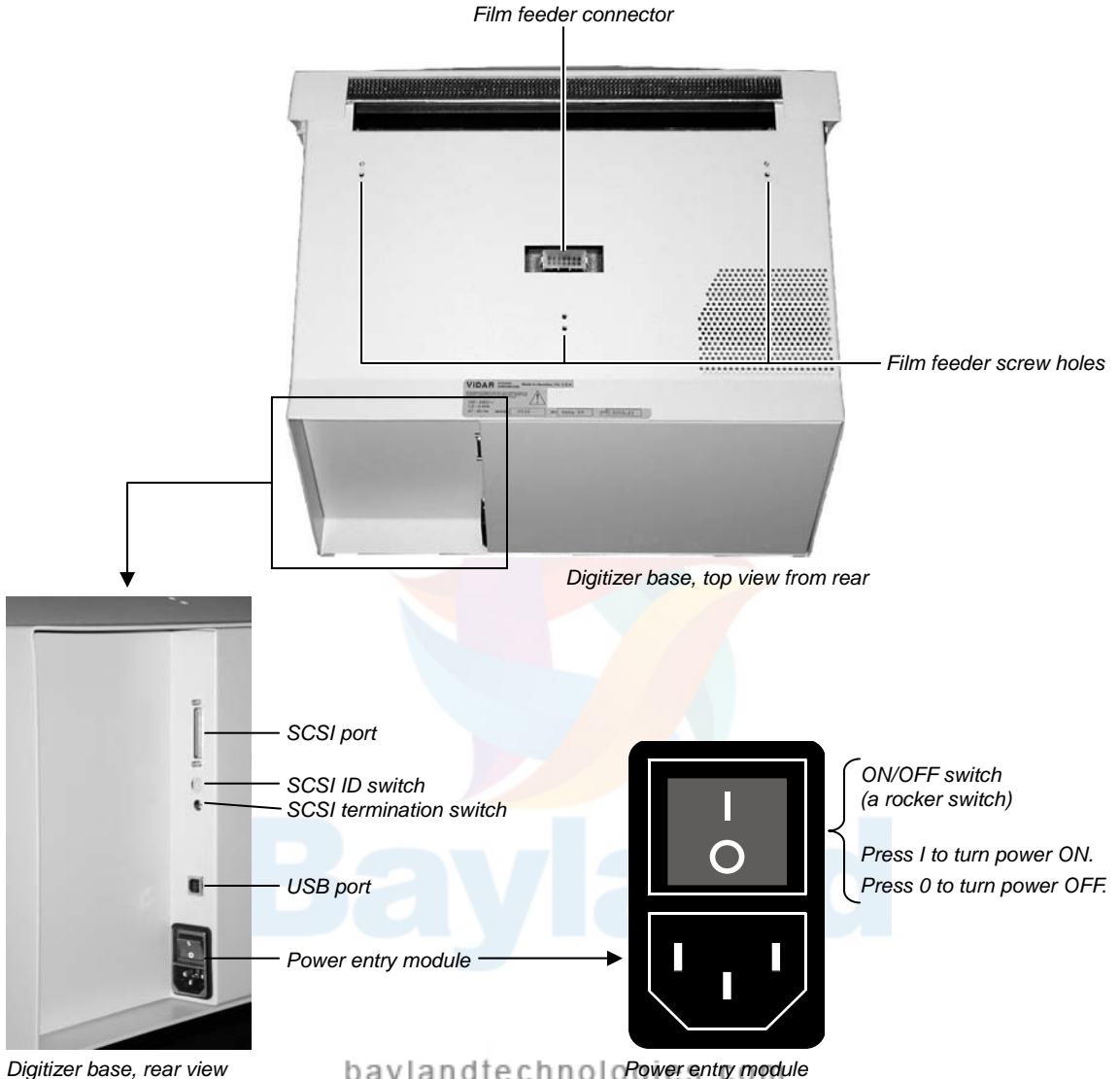

baylandtechnology.com  
 telephone: 1-800-801-8432

## Assemble the digitizer

1. Place the stand on a solid, flat surface (such as a table).
2. Place the digitizer base on the stand as shown below. Tighten the thumbscrews on the bottom of the stand to secure it to the digitizer.

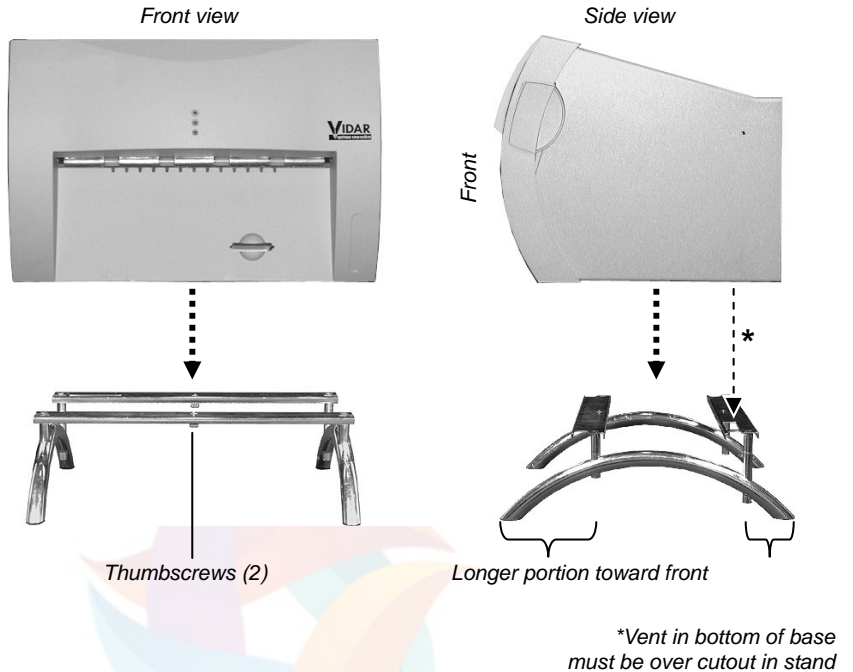

# Bayland

baylandtechnologies.com  
telephone: 1-800-801-8432

### 3. Attach the feeder to the digitizer:

- a. Note the three screws protruding from the bottom of the feeder. These mate to holes in the digitizer base. Two of the screws are very long—their tops ends are near the top of the feeder.

Also note the connector on the bottom of the feeder. It mates to the connector on top of the digitizer base.

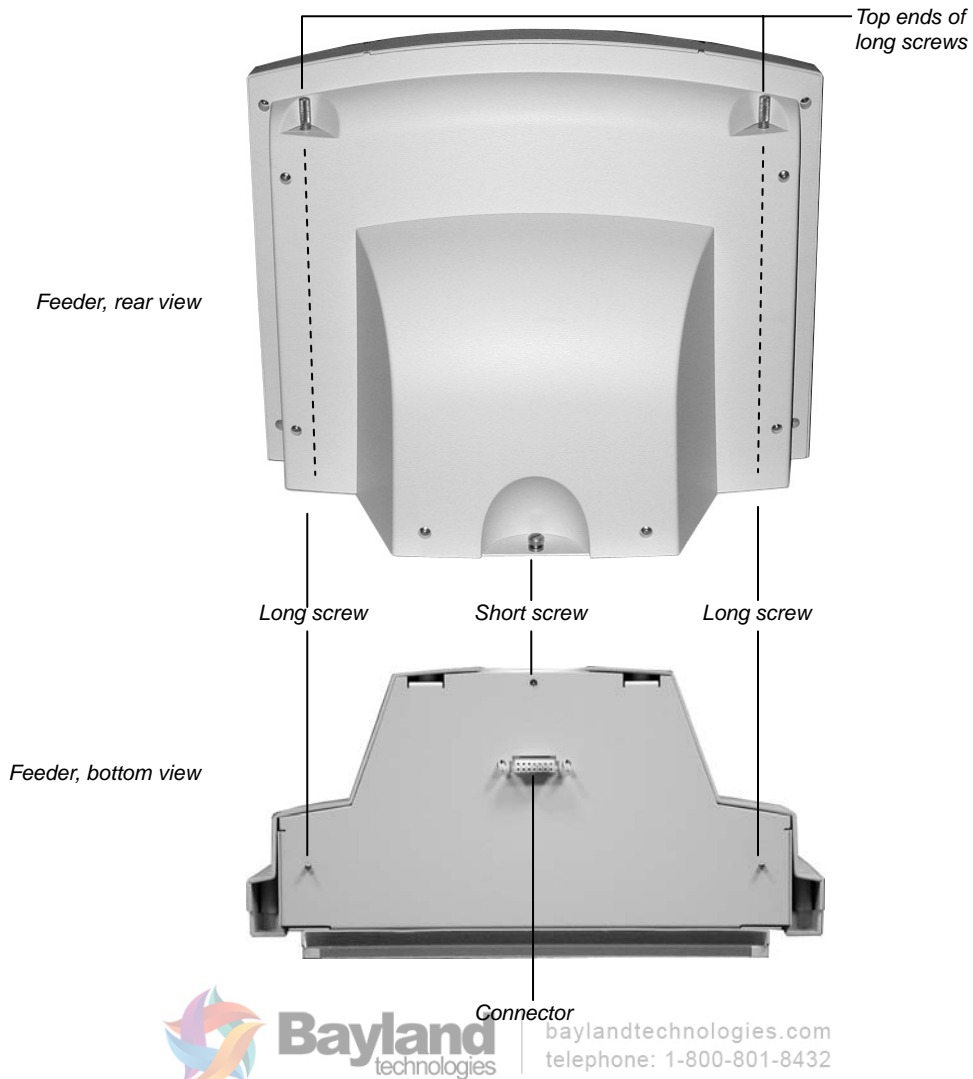

- b. Place the feeder on top of the digitizer, and slide the feeder connector into the digitizer connector.



- c. On the rear of the feeder, tighten the three screws to secure the feeder to the digitizer base.

Screws

- You may need to move the feeder slightly to get the screws started in the holes.
- Tighten each screw a few turns, then repeat until all are finger tight.

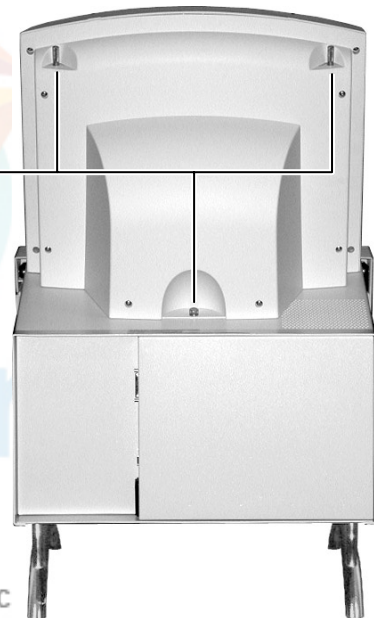

baylandtechnologies.com  
telephone: 1-800-801-8432

4. Install the exit tray by hooking it over the notched plastic edge just below the rollers. When the exit tray is properly positioned, it will be parallel to the roller shaft.



Bayland

baylandtechnologies.com  
telephone: 1-800-801-8432

5. Insert the film support bar legs into the two holes on the film feeder's top edge. The film support bar's curved center portion must face the front of the film feeder.

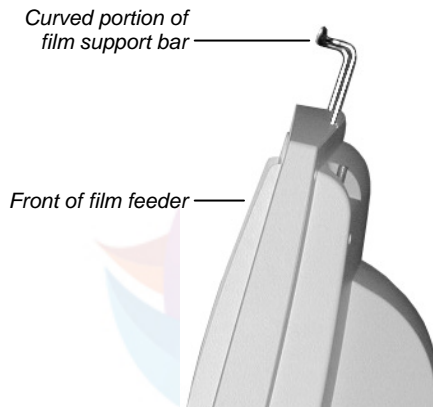
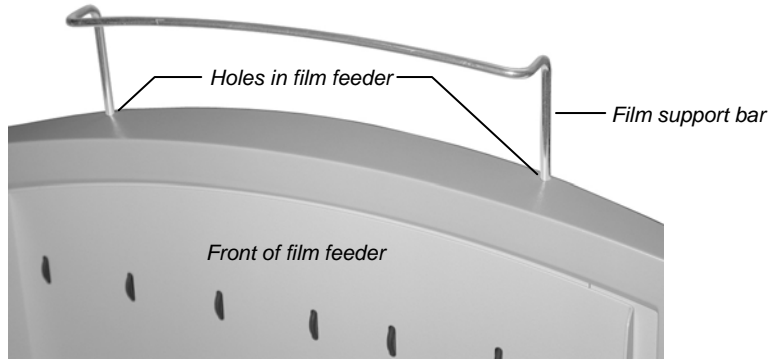

**IMPORTANT:** Do not lift or carry the digitizer using the film support bar.

baylandtechnologies.com  
telephone: 1-800-801-8432

**Warning**

Before you begin the installation procedure, turn off all power to the computer and peripherals. Connecting the SCSI cable with the power on can cause serious damage to the unit or your computer.

**Précaution**

Avant de commencer la connexion, assurez vous que votre ordinateur soit bien éteint. Toute connexion du cable SCSI et courant, pourrait gravement endommager votre numériseur ou ordinateur.

**Advertencia**

Antes de continuar con la instalación, favor de apagar su computadora y periférico. Conectando el cable SCSI con la computadora prendida puede causar daño al equipo o a su computadora.

**Warnung**

Vor dem Installieren den Computer und angeschlossene Geräte ausschalten. Durch Anschluß des SCSI Kabels an angeschaltete Geräte können ernsthafte Schäden entstehen.



baylandtechnologies.com  
telephone: 1-800-801-8432

## Connect the power cord

1. Connect the power cord to the digitizer's Power Entry Module (PEM), located on the rear of the digitizer.
2. Connect the other end of the power cord to a grounded power outlet.



**Note:** The film digitizer has an auto-sensing power supply. When you apply power, the digitizer will detect the voltage and set itself for proper operation.



Bayland

baylandtechnologies.com  
telephone: 1-800-801-8432



## Where to go from here...

How you proceed depends on how you will be connecting the digitizer to your computer:

- If the digitizer will be connected via a **SCSI interface**, continue the installation using the following sequence of sections in this manual:
  - “VIDAR Drivers and Toolkit CD and Driver Information”
  - “SCSI Settings”
  - “Installing SCSI hardware”
  - “Installing SCSI Drivers”
  - “Updating the VIDAR Toolkit”
  - “Operating DIAGNOSTICPRO™ Advantage and DOSIMETRYPRO™ Advantage”
  
- If the digitizer will be connected via a **USB interface**, continue the installation using the following sequence of sections in this manual:
  - “VIDAR Drivers and Toolkit CD and Driver Information”
  - “Installing USB Drivers”
  - “Updating the VIDAR Toolkit”
  - “Operating DIAGNOSTICPRO™ Advantage and DOSIMETRYPRO™ Advantage”



baylandtechnologies.com  
telephone: 1-800-801-8432



# CADPRO™ Advantage Installation Guide



baylandtechnologies.com  
telephone: 1-800-801-8432



# Unpacking

---

## 1. Look for damage

Before unpacking the film digitizer, examine the shipping carton for damage.

If the carton is damaged, notify the shipper immediately.

**IMPORTANT:** Save the carton and all packing materials. If you need to ship the digitizer later, you **must** repack it using the original wire ties, plastic bags, foam supports and cartons. Instructions for repacking are provided in “Appendix: Packing the film digitizer for shipment.”



baylandtechnologies.com  
telephone: 1-800-801-8432

## 2. Unpack the shipping carton

Remove items from the shipping carton in the order shown below.

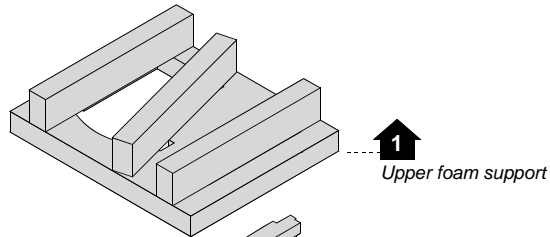

**Note:** For clarity, this illustration does not show the plastic bags surrounding the digitizer and feeder.

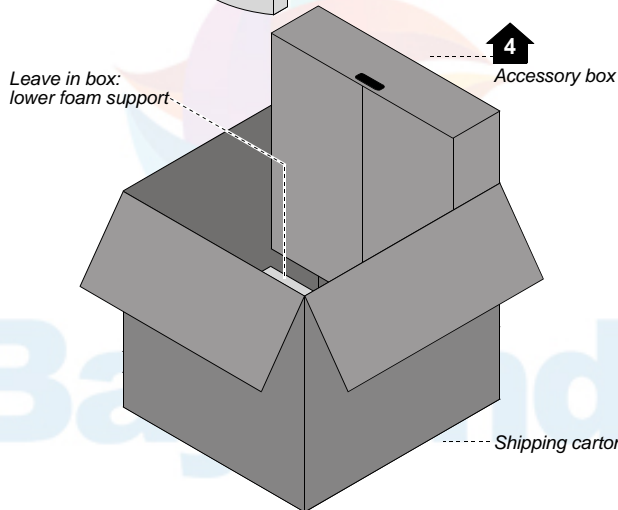
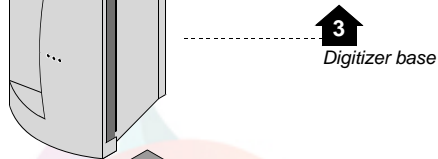
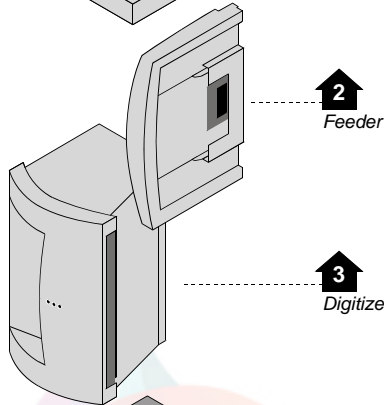

baylandtechnologies.com  
telephone: 1-800-801-8432

### 3. Unpack the accessory box

a. Remove these items from the accessory box:

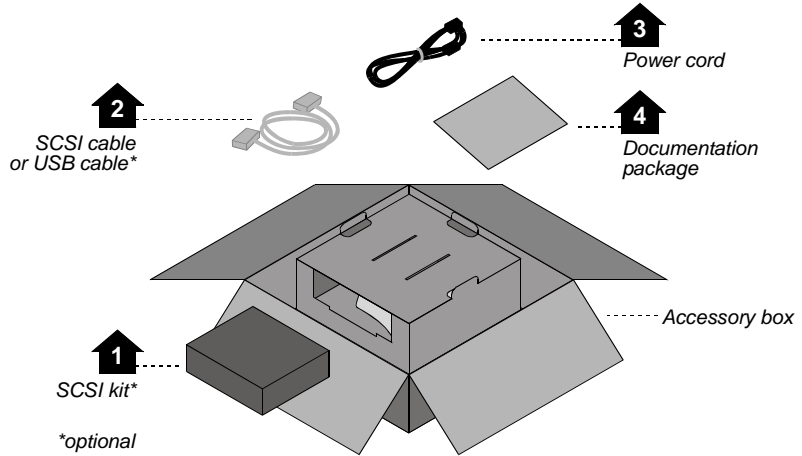

baylandtechnologies.com  
telephone: 1-800-801-8432

b. Then remove these items from the accessory box:

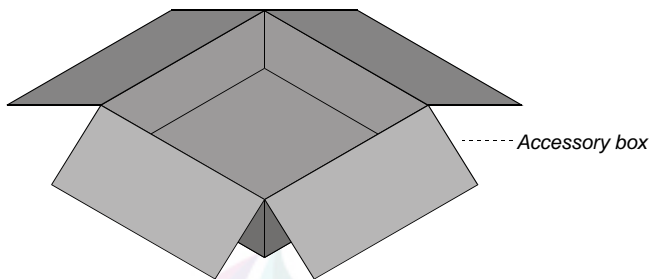
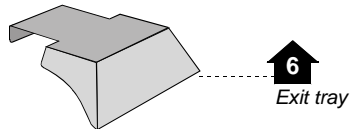
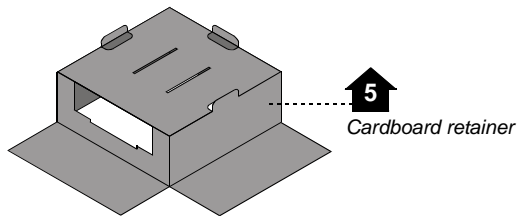

**Note:** For clarity, this illustration does not show the plastic bag surrounding the exit tray.



Bayland

The Bayland logo features a stylized, multi-colored flower or leaf design in shades of blue, purple, orange, and yellow, positioned above the word 'Bayland' in a large, light blue, sans-serif font.

baylandtechnologies.com  
telephone: 1-800-801-8432

## 4. Unwrap

- a. Unwrap all items.
- b. Remove the foam block from the rear of the digitizer base:

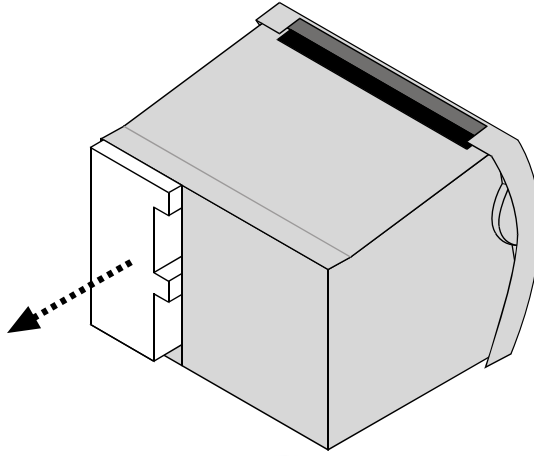

- c. Locate the foam wedge on the bottom of the feeder.

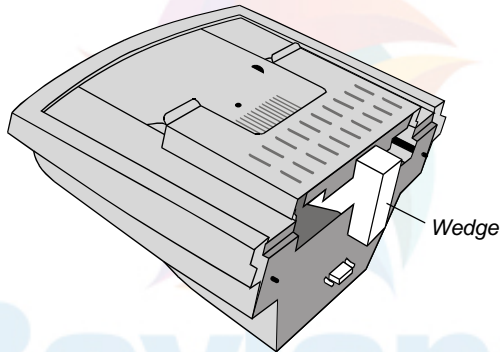

baylandtechnologies.com  
telephone: 1-800-801-8432

- d. Remove the wedge from the feeder as shown below.

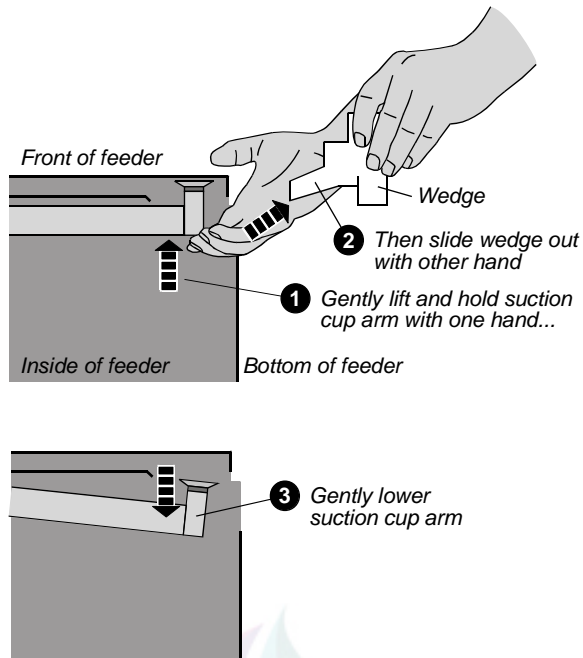

**IMPORTANT:** Save the carton and all packing materials. If you need to ship the digitizer later, you **must** repack it using the original wire ties, plastic bags, foam supports and cartons. Instructions for repacking are provided in "Appendix: Packing the film digitizer for shipment."

Bayland

baylandtechnologies.com  
telephone: 1-800-801-8432



## 5. Identify the components

- | ✓                        | Item  |
|--------------------------|---|
| <input type="checkbox"/> | Digitizer base  |
| <input type="checkbox"/> | Exit tray   |
| <input type="checkbox"/> | 50 sheet film feeder <b>or</b> 100 sheet film feeder          |
| <input type="checkbox"/> | Power cord: 115V (p/n 4043-001) <b>or</b> 230V (p/n 2104-006) |
| <input type="checkbox"/> | <i>Important Safety Information card</i> (on film feeder)     |
| <input type="checkbox"/> | <i>Quick setup card</i>                                       |



Digitizer base

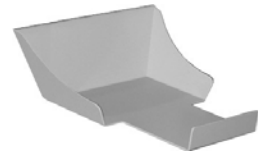

Exit tray



50 sheet feeder

**or**



100 sheet feeder

- | ✓                        | Other items* (see footnote)  |
|--------------------------|--|
| <input type="checkbox"/> | Adaptec 2930 SCSI kit (p/n 3053) and<br>SCSI cable: 6 foot MMD-50 to SCSI III 68-pin male (p/n 4270) |
| <input type="checkbox"/> | USB cable: 6 foot (p/n 4618)   |

\*You will receive either a SCSI kit and SCSI cable **or** a USB cable, as specified at time of order.

maylandtechnologies.com  
telephone: 1-800-801-8432

## 6. If anything is missing...

Immediately contact your VIDAR supplier.

## 7. Activate your product warranty

Complete the warranty information/customer survey form at the back of this manual and mail it to VIDAR Systems Corp.

If your digitizer needs service, this information should be on file at VIDAR.

**Contact VIDAR Technical Support** if you have any questions about installing or using your VIDAR film digitizer:

Phone: +1.800.471.SCAN (+1.800.471.7226)

+1.703.471.7070 outside the U.S.

E-mail: [medtech@vidar.com](mailto:medtech@vidar.com)

---

**NEXT:** Go to “Setting up” ⇒

---



Bayland

baylandtechnologies.com  
telephone: 1-800-801-8432

# Setting up

The digitizer must be placed on a cart, counter or tabletop.

## SAFETY WARNING

Never place the digitizer on the floor.

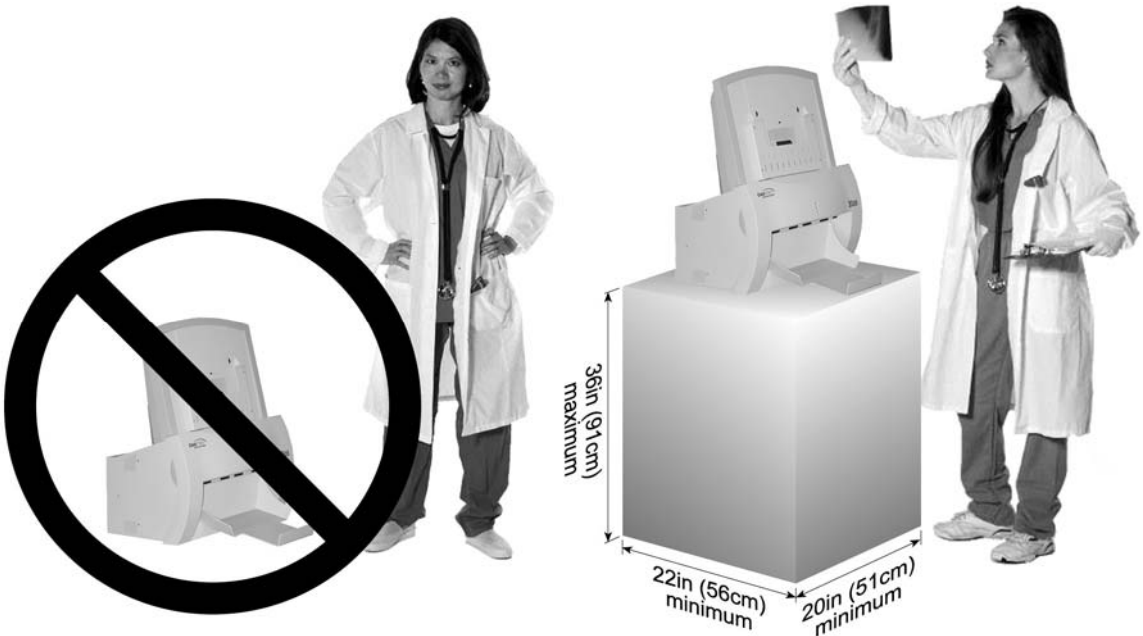

**Bayland**  
technologies

baylandtechnologies.com  
telephone: 1-800-801-8432

## Identify important features

Look over the digitizer base and locate the features shown in this section. You will need to know where these features are when you assemble and operate the digitizer in later chapters.

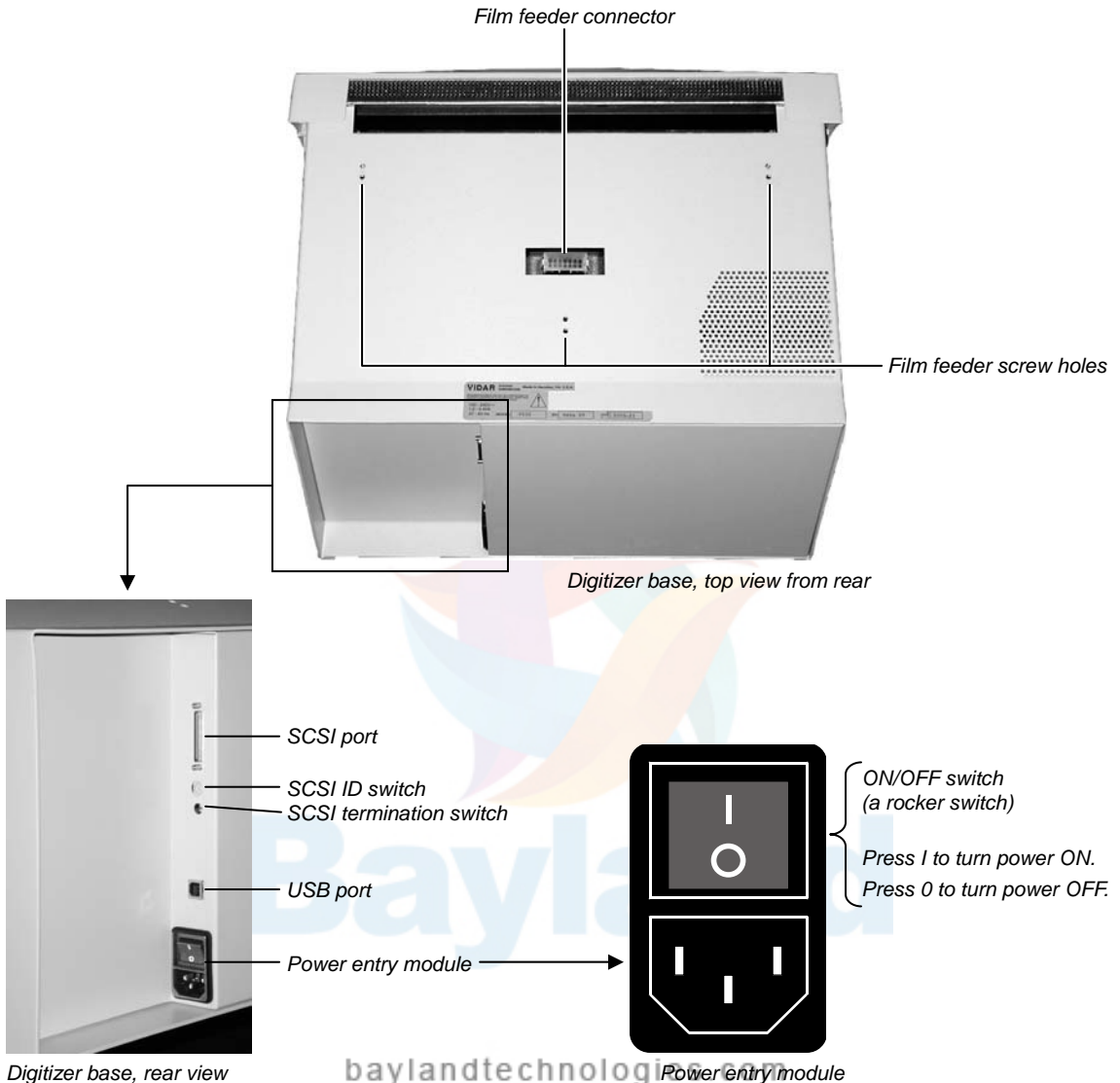

baylandtechnology.com  
 telephone: 1-800-801-8432

## Assemble the digitizer

1. Place the digitizer base on a solid, flat surface (such as a table).

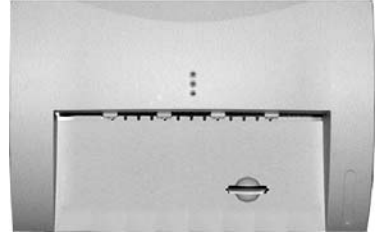

baylandtechnologies.com  
telephone: 1-800-801-8432

## 2. Attach the feeder to the digitizer:

- a. Note the three screws protruding from the bottom of the feeder. These mate to holes in the digitizer base. Two of the screws are very long—their top ends are near the top of the feeder.

Also note the connector on the bottom of the feeder. It mates to the connector on top of the digitizer base.

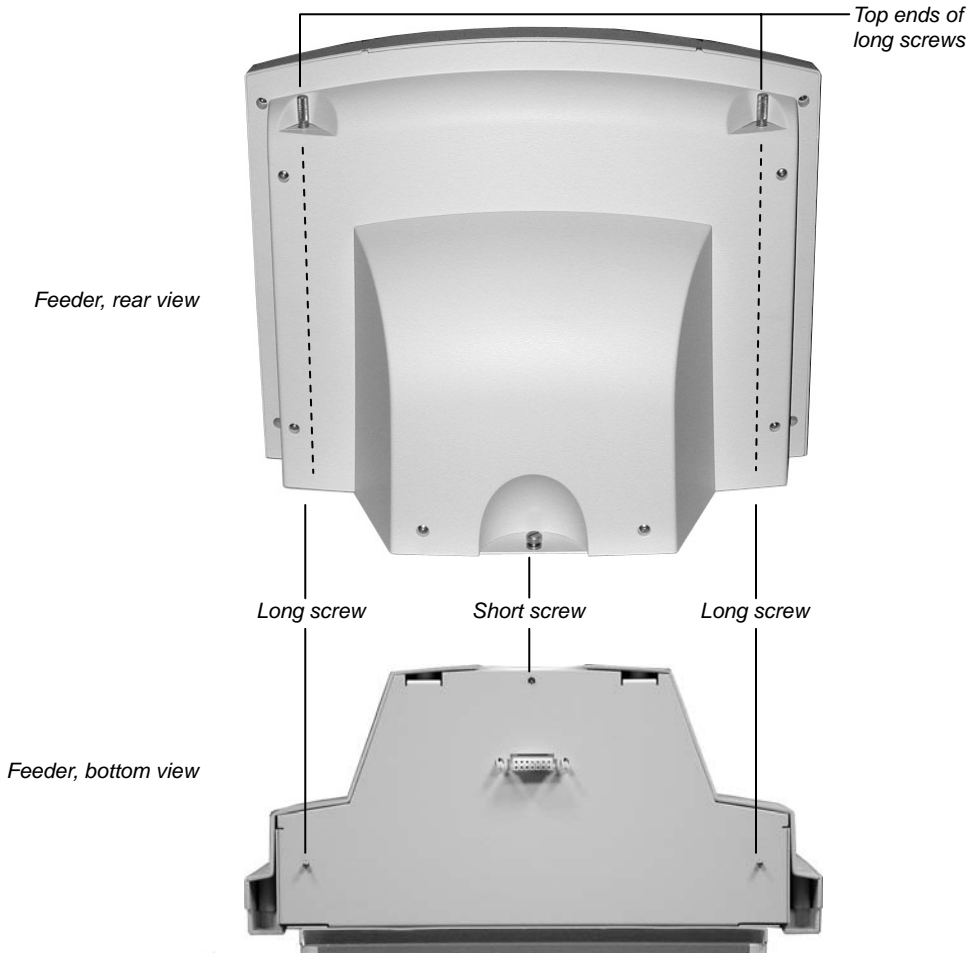

**Bayland**  
technologies

Connector

baylandtechnologies.com  
telephone: 1-800-801-8432

- b. Place the feeder on top of the digitizer, and slide the feeder connector into the digitizer connector.

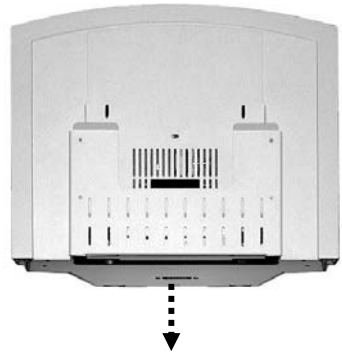

- c. On the rear of the feeder, tighten the three screws to secure the feeder to the digitizer base.

- You may need to move the feeder slightly to get the screws started in the holes.
- Tighten each screw a few turns, then repeat until all are finger tight.

Screws

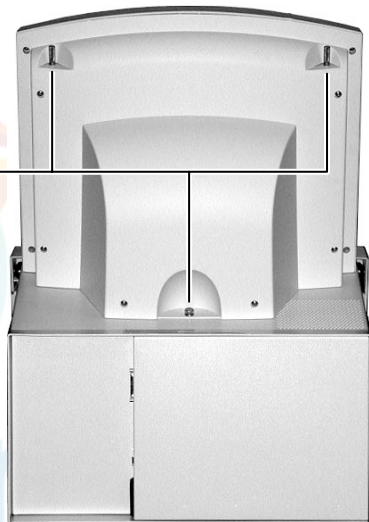

baylandtechnologies.com  
telephone: 1-800-801-8432

3. Install the exit tray by hooking it over the notched plastic edge just below the rollers. When the exit tray is properly positioned, it will be parallel to the roller shaft.

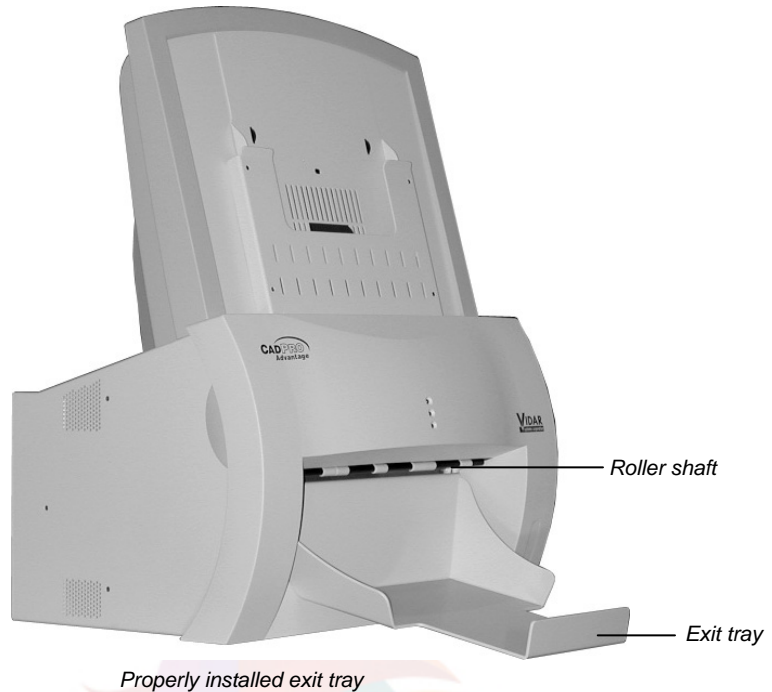

baylandtechnologies.com  
telephone: 1-800-801-8432



## Connect the power cord

1. Connect the power cord to the digitizer's Power Entry Module (PEM), located on the rear of the digitizer.
2. Connect the other end of the power cord to a grounded power outlet.



**Note:** The film digitizer has an auto-sensing power supply. When you apply power, the digitizer will detect the voltage and set itself for proper operation.



Bayland

baylandtechnologies.com  
telephone: 1-800-801-8432

## Where to go from here...

How you proceed depends on how you will be connecting the digitizer to your computer:

- If the digitizer will be connected via a **SCSI interface**, continue the installation using the following sequence of sections in this manual:
  - “VIDAR Drivers and Toolkit CD and Driver Information”
  - “SCSI Settings”
  - “Installing SCSI hardware”
  - “Installing SCSI Drivers”
  - “Updating the VIDAR Toolkit”
  - “Operating CADPRO™ Advantage”
  
- If the digitizer will be connected via a **USB interface**, continue the installation using the following sequence of sections in this manual:
  - “VIDAR Drivers and Toolkit CD and Driver Information”
  - “Installing USB Drivers”
  - “Updating the VIDAR Toolkit”
  - “Operating CADPRO™ Advantage”



baylandtechnologies.com  
telephone: 1-800-801-8432



baylandtechnologies.com  
telephone: 1-800-801-8432

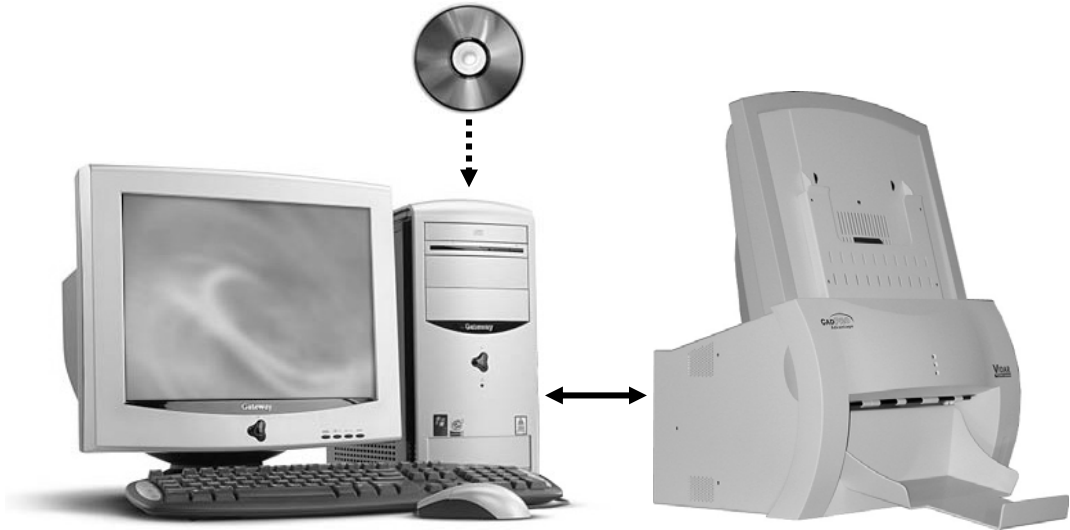

## Interfacing Guide

Bayland

baylandtechnologies.com  
telephone: 1-800-801-8432

**VIDAR**  
systems corporation  
Medical Imaging



[baylandtechnologies.com](http://baylandtechnologies.com)  
telephone: 1-800-801-8432

## VIDAR device driver summary

Operating system	Device driver	EZ-SCSI Software	Update Toolkit ( <i>vscsi32.dll</i> )	CDs needed
Windows™ XP Professional Edition, Service Pack 1 or higher	Vidar STI	No	Yes	VIDAR Drivers and Toolkit Installation CD
Windows™ 2000 with Service Pack 2 or higher* * Service Pack 4 or higher is required for USB connectivity	Vidar STI	No	Yes	VIDAR Drivers and Toolkit Installation CD

**WARNING:** VIDAR has validated the STI driver and replacement of *vscsi32.dll* with all supported VIDAR digitizers on both Windows™ 2000 and Windows™ XP systems using several third party software applications. No bugs or problems were identified during validation testing. However, you must check with your system integrator or scanning software vendor to verify that they support the replacement of VIDAR's *vscsi32.dll*.

## About the STI drivers

Previously, most system integrators built their scanning applications for VIDAR digitizers based on either the VIDAR SCSI Toolkit or the ActiveX control (based on the SCSI Toolkit). VIDAR's SCSI Toolkit was based on Adaptec's ASPI drivers. However, Adaptec™ is not supporting its ASPI drivers for Microsoft Windows™ 2000 or XP. Therefore, VIDAR developed a toolkit that takes advantage of Microsoft's Still Image Architecture (STI) for digital imaging devices. The new VIDAR Toolkit and VIDAR STI driver support several operating system enhancements.

The VIDAR STI driver was designed to provide compatibility between VIDAR medical film digitizers and Windows™ 2000 and XP. Features of this driver include:

- Installation/setup wizard for easy and consistent installation.
- Scanners and Cameras Control Panel, which provides a common interface for still image devices.
- No need to rely on unsupported ASPI-layer drivers from Adaptec™ for SCSI adapters.

The VIDAR STI driver works with the new Toolkit (*vscsi32.dll*). The Toolkit was developed specifically to support the STI architecture:

- It is a direct replacement for previous *vscsi32.dlls*.
- No recompiles are necessary.
- Existing applications are easily configured to work with the Toolkit.

---

**NEXT: If connecting digitizer via SCSI, go to “SCSI settings”** ⇨

or

**If connecting digitizer via USB, go to “Installing USB drivers”** ⇨

---

The logo for Bayland Technologies, featuring a stylized, multi-colored circular emblem with overlapping segments in shades of purple, blue, and yellow, resembling a flower or a globe. Below the emblem, the word "Bayland" is written in a large, light blue, sans-serif font.

Bayland

baylandtechnologies.com  
telephone: 1-800-801-8432

# SCSI settings

---

**Warning**

Before you begin the installation procedure, turn off all power to the computer and peripherals. Connecting the SCSI cable with the power on can cause serious damage to the unit or your computer.

**Précaution**

Avant de commencer la connexion, assurez vous que votre ordinateur soit bien éteint. Toute connexion du câble SCSI et courant, pourrait gravement endommager votre numériseur ou ordinateur.

**Advertencia**

Antes de continuar con la instalación, favor de apagar su computadora y periférico. Conectando el cable SCSI con la computadora prendida puede causar daño al equipo o a su computadora.

**Warnung**

Vor dem Installieren den Computer und angeschlossene Geräte ausschalten. Durch Anschluß des SCSI Kabels an angeschaltete Geräte können ernsthafte Schäden entstehen.



baylandtechnologies.com  
telephone: 1-800-801-8432



## If necessary, set the digitizer's SCSI ID

A computer equipped with a SCSI bus can communicate with multiple SCSI devices (for example: a film digitizer, a scanner and a disk drive). Each device must have a unique SCSI ID number so the computer can distinguish it from other SCSI devices. Valid SCSI ID numbers range from 1 to 6.

When selecting SCSI ID numbers:

- The SCSI Card 2930U is preset to SCSI ID 7 and should not be changed.
- Set the film digitizer to any SCSI ID between 1 and 6, as long as that number is not used by another SCSI device attached to the computer.

**Note:** The digitizer is shipped from the factory with the SCSI ID preset to 3.

- If the system is configured to boot from a SCSI disk drive, it's best to set the disk's SCSI ID to 0 or 1. Most SCSI disks are preset to SCSI ID 0 at the factory.

**CAUTION:** The digitizer and computer MUST be turned OFF before changing the SCSI ID.

To set the digitizer's SCSI ID:

1. Locate the SCSI ID switch on the back of the digitizer below the SCSI port connector.
2. Change the SCSI ID switch using a 1/8" or #2 flat blade screwdriver.

**Note:** Do not set the switch to 0, 7, 8, 9, A, B, C, D or F.

**CAUTION:** Do not force switch rotation. Do not use a large screwdriver to rotate the switch.

telephone: 1-800-801-8432

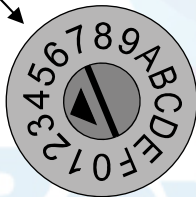

## If necessary, terminate the SCSI bus

The film digitizer has a single SCSI port connector, and must be connected directly to the computer or connected at the end of a SCSI chain. In this configuration, the digitizer must provide termination for the SCSI bus. The digitizer was set for SCSI bus termination at the factory. **VIDAR strongly recommends that you not change the factory SCSI termination setting.**

**Note:** If you cannot install the digitizer at the end of a SCSI chain, please contact VIDAR Technical Support for instructions (+1.703.471.7070 or medtech@vidar.com).

**Note:** When the film digitizer is at the end of the SCSI chain, the SCSI termination switch **must** be set for SCSI termination. Consult your SCSI controller manual regarding proper use of termination.

If you determine that the film digitizer's SCSI termination is not set for internal termination (left picture below), here is how to change the setting to deactivate internal termination:

1. Locate the SCSI termination switches on the back of the digitizer.
2. Push both switches as shown below.

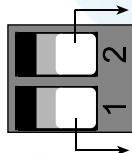

**Factory (recommended)  
termination switch setting**

Switches  
pushed  
this way

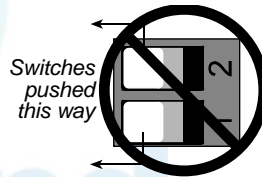

Switches  
pushed  
this way

**Not recommended**

baylandtechnologies.com  
telephone: 1-800-801-8432

## Connect the SCSI cable to the digitizer

Use only a shielded 1.8 meter (6 ft) VIDAR SCSI cable (part number 4270). This cable has a 68-pin high density connector that attaches to the digitizer, and a 50-pin connector that attaches to the SCSI adapter in the computer (to be installed later). Use of SCSI cables from other sources may violate safety and emissions compliances.

**Note:** Attach or remove the SCSI cable carefully to avoid bending the connector pins. Insert the connector straight into the SCSI port. Inserting the connector at an angle may damage the pins. If the pins or cable are damaged, improper SCSI operation may result.

**Note:** Before connecting the SCSI cable, be certain that the SCSI cable isn't connected to anything else and the digitizer power supply is unplugged.

1. **Carefully** attach the 68-pin high density SCSI connector to the film digitizer's SCSI port, located on the rear of the digitizer. Apply even pressure to avoid bending SCSI connector pins. **Do not force the connectors together.**

Do not connect the other end of the cable at this time.

**WARNING:** If the SCSI connector has bent pins, it will damage the SCSI port in the digitizer. Do not attempt to straighten bent pins. Discard any SCSI cable with bent pins and replace it with a new cable.



**NEXT:** Go to “Installing SCSI hardware” ➡

baylandtechnologies.com  
telephone: 1-800-801-8432

# Installing SCSI hardware

---

A SCSI card (also known as a controller or host adapter) is required to enable the VIDAR film digitizer to communicate with your computer. VIDAR digitizers have been validated with the Adaptec™ 2930CU SCSI adapter card. Do not use other SCSI adapter cards. Ultra-wide SCSI adapters are not compatible with VIDAR film digitizers.

A computer equipped with a SCSI bus can communicate with multiple SCSI devices (for example: a film digitizer, a scanner and a disk drive). Each device must have a unique SCSI ID number so the computer can distinguish it from other SCSI devices. Valid SCSI ID numbers range from 1 to 7, but ID 7 is reserved for the SCSI adapter. Instructions for setting the film digitizer's SCSI ID number are provided in the previous chapter.



baylandtechnologies.com  
telephone: 1-800-801-8432

**Warning**

Before you begin the installation procedure, turn off all power to the computer and peripherals. Connecting the SCSI cable with the power on can cause serious damage to the unit or your computer.

**Précaution**

Avant de commencer la connexion, assurez vous que votre ordinateur soit bien éteint. Toute connexion du cable SCSI et courant, pourrait gravement endommager votre numériseur ou ordinateur.

**Advertencia**

Antes de continuar con la instalación, favor de apagar su computadora y periférico. Conectando el cable SCSI con la computadora prendida puede causar daño al equipo o a su computadora.

**Warnung**

Vor dem Installieren den Computer und angeschlossene Geräte ausschalten. Durch Anschluß des SCSI Kabels an angeschaltete Geräte können ernsthafte Schäden entstehen.



baylandtechnologies.com  
telephone: 1-800-801-8432

## 1. Install the SCSI card.

This section provides general instructions for installing the SCSI card. Refer to your computer's manual for specific instructions.

- a. Turn off power to the computer and disconnect the computer's power cord from the electrical outlet.
- b. Remove the cover from the computer. (Refer to the computer's manual for instructions on removing the cover.)

**Tip:** If the computer is a tower model, it's easier to install the SCSI card when the tower is laid on its side.

- c. Locate an unused PCI expansion slot (PCI connectors are typically white or ivory). Remove the expansion slot cover. Save the slot cover screw for use in step g.

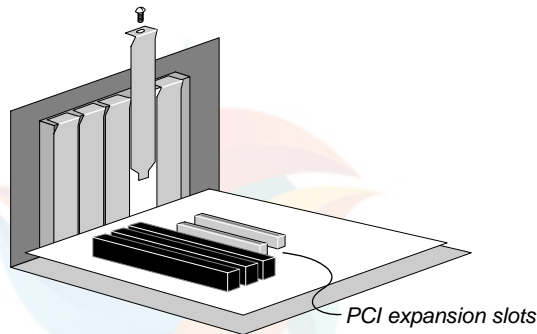

- d. Before handling the SCSI card, discharge your static electricity by touching a metal part on the computer chassis.
- e. Remove the SCSI Card from its anti-static packaging. **Handle the card only by its edges.**

*continued*

baylandtechnologies.com  
telephone: 1-800-801-8432

- f. Insert the SCSI Card into the PCI expansion slot. Press down firmly until the SCSI card clicks into place.

*These slightly tilted cards are incorrectly seated in the slot*

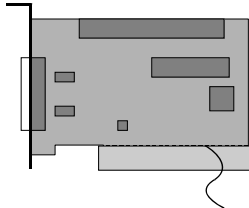

*When properly seated, the gold fingers along the bottom of the card should hardly show*

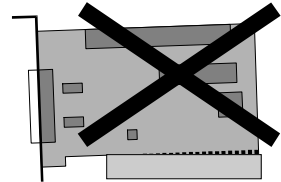
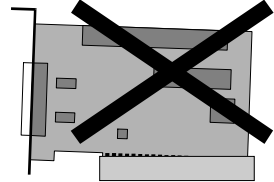

- g. Secure the SCSI card with the expansion slot screw you removed in step c.
- h. Replace the cover on the computer.

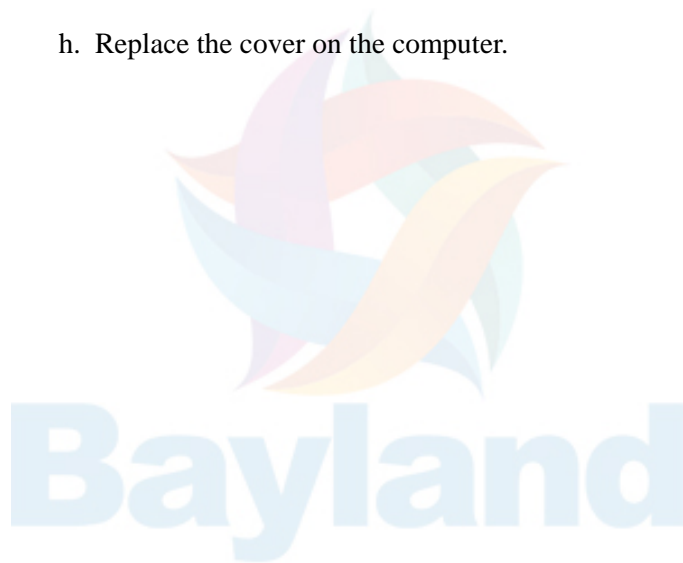

baylandtechnologies.com  
telephone: 1-800-801-8432

## 2. Configure the SCSI BIOS

**Note:** This step is required for SCSI installations.

### A. Turn on the digitizer



1. Ensure the PC is turned **off**.

**Note:** Always apply power to the digitizer before turning on the computer. This enables the computer to recognize the digitizer.

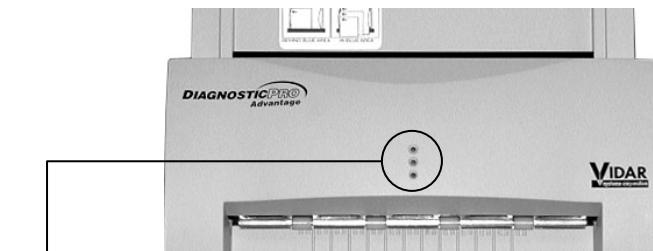
2. Turn on the digitizer.
3. Watch the LEDs on the front of the digitizer. **Wait until all LEDs are solid green (center LED may flash slowly).** Then proceed to step 2, next in this chapter.



**Note:** When you turn on the digitizer, several minutes are required for the digitizer to carry out its internal diagnostics.

	Location	Function	Normal state
	Top LED	Feeder status	Solid green
	Center LED	Digitizer status	Solid green, but slow flashing when digitizer is busy
	Bottom LED	Power status	Solid green

**Note:** For more information about LED states, see “Appendix: troubleshooting,” later in this manual.

telephone: 1-800-801-8432



## B. Edit the SCSI adapter BIOS settings

In most cases, the digitizer is not properly detected after you install the SCSI adapter. This is because the computer tries to boot from the adapter, but no SCSI hard disk is connected. You must correct this behavior in the SCSI BIOS.

1. Turn on or restart your computer. When the computer boots up, it will detect the SCSI Adapter. When this message appears on the screen, *immediately* press CTRL+A:

**Press Ctrl+A for SCSISelect™ Utility!**

(The message appears for just a few seconds.)

**Note:** In the next steps, use keyboard ARROW keys to navigate within a screen. When you have selected the desired option, press ENTER.

2. In the **Options** menu (see below), select the **Configure/View Host Adapter Settings** option, then press ENTER.

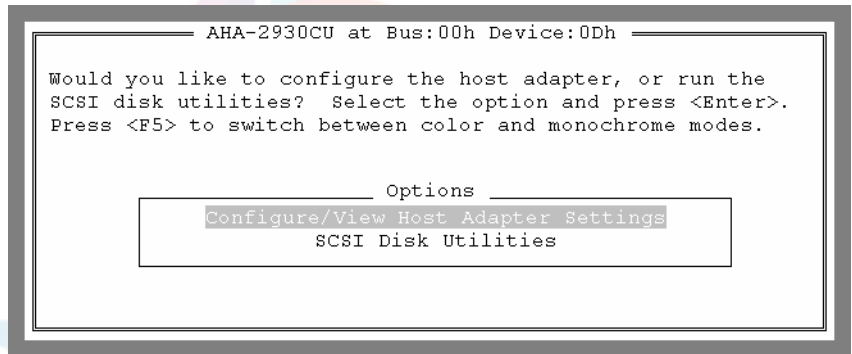

baylandtechnologies.com  
telephone: 1-800-801-8432

3. Under **Additional Options**, select **SCSI Device Configuration** (see below). Press ENTER.

```

      AHA-2930U at Bus:00h Device:0Dh
----- Configuration -----
SCSI Bus Interface Definitions
Host Adapter SCSI ID..... 7
SCSI Parity Checking..... Enabled
Host Adapter SCSI Termination..... Automatic

Additional Options
Boot Device Options..... Press <Enter>
SCSI Device Configuration..... Press <Enter>
Advanced Configuration Options..... Press <Enter>

      <F6> - Reset to Host Adapter Defaults

----- BIOS Information -----
Interrupt (IRQ) Channel..... 11
I/O Port Address.....1000h
  
```

4. You will see SCSI Device ID #s 0 to 7. **Initiate Sync Negotiation** will be set to **Yes** or **No**. Set them all to **No**. Set **Maximum Sync Transfer Rate** to **10.0** for all. Press ESC to exit this screen.

```

      SCSI Device Configuration
-----
SCSI Device ID          #0  #1  #2  #3  #4  #5  #6  #7
-----
Initiate Sync Negotiation..... no  no  no  no  no  no  no  no
Maximum Sync Transfer Rate(MB/Sec) 10.0 10.0 10.0 10.0 10.0 10.0 10.0 10.0
Enable Disconnection..... yes  yes  yes  yes  yes  yes  yes  yes

----- Options Listed Below Have NO EFFECT if the BIOS is Disabled -----
Send Start Unit Command..... no  no  no  no  no  no  no  no
BIOS Multiple LUN Support..... no  no  no  no  no  no  no  no
Include in BIOS Scan..... yes  yes  yes  yes  yes  yes  yes  yes
  
```

# Bayland

baylandtechnologies.com  
telephone: 1-800-801-8432

5. Select **Advanced Configuration Options** (see below) and press ENTER.

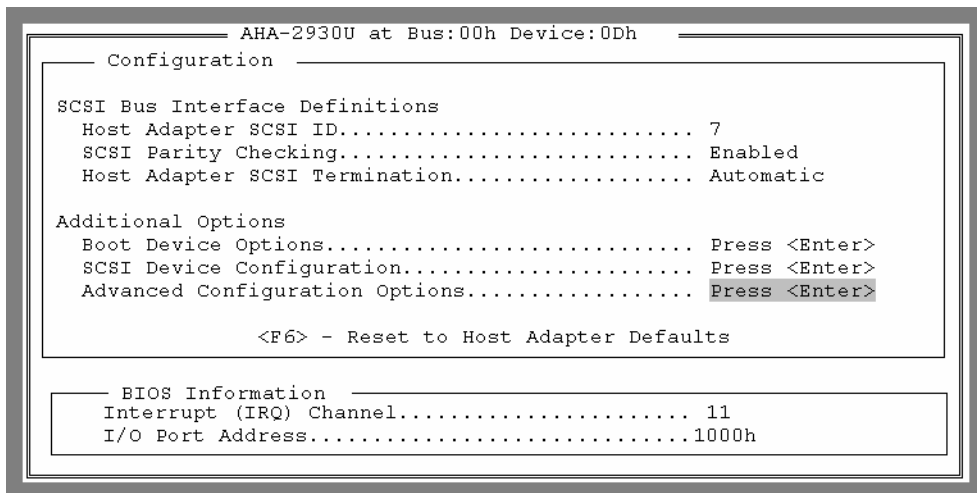

6. Select **Host Adapter Bios**. Set to **Disabled**.
7. Press ESC, then **SAVE SETTINGS**, then **REBOOT**.

**NEXT:** Go to "Installing SCSI drivers" ➡

Bayland

baylandtechnologies.com  
telephone: 1-800-801-8432

# Installing SCSI drivers

---

**Note:**

- On Windows™ 2000 computers, Service Pack 2 or higher must be installed for SCSI installations. Computers without Service Pack 2 or higher will not be supported.
- On Windows™ XP Professional Edition, Service Pack 1 or higher must be installed for SCSI installations.

VIDAR's STI device driver provides compatibility between VIDAR film digitizers/scanners and **Windows™ 2000 and Windows™ XP only**. The STI driver takes advantage of Microsoft's Still Image Architecture (STI) for digital imaging devices.

You will need:

- VIDAR Drivers and Toolkit Installation CD.

**Note:** These instructions have been successfully tested on a wide range of Windows™ 2000 and Windows™ XP systems. In rare instances, you may have difficulty installing the STI driver. If that happens, try again after logging on as Administrator, or as a user with Administrator rights.

1. Be sure the digitizer is turned OFF, and is NOT connected to the PC. Wait until you are prompted to connect the digitizer.
2. Turn on the PC.
3. Insert the **VIDAR Drivers and Toolkit Installation CD** into the CD-ROM. The installer should launch automatically.

baylandtechnologies.com  
telephone: 1-800-801-8432

If the installer does not launch automatically, double-click the appropriate CD drive icon under **My Computer** in Windows™ Explorer.

4. In the first screen, click **Install Software**.

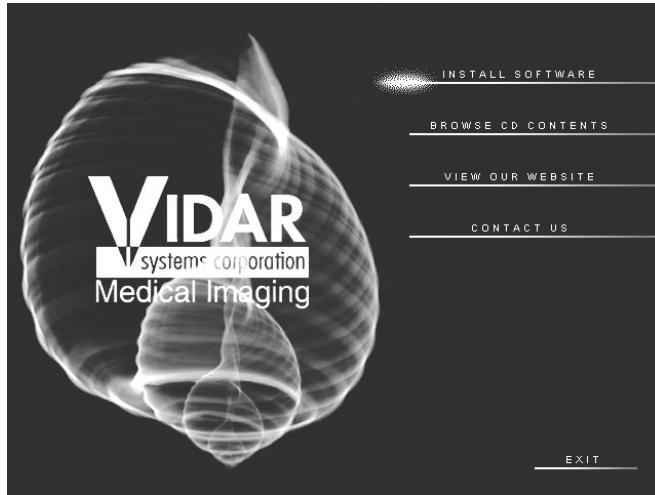

5. In the next screen, click **Install Digitizer Driver**.



6. You will see a message that the InstallShield Wizard is starting.

7. In the InstallShield Welcome screen, click **Next**.

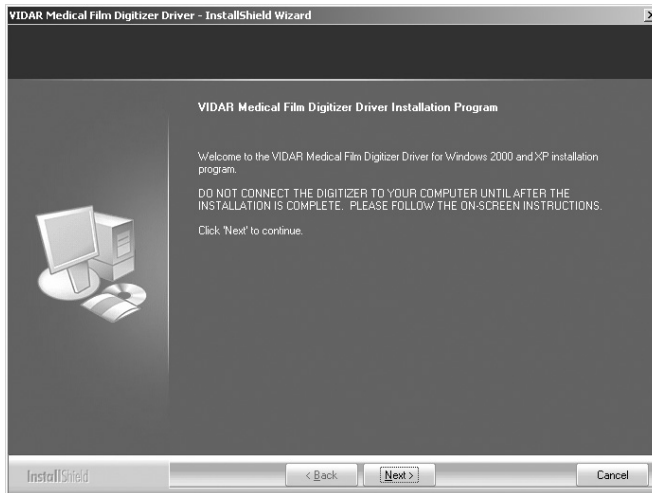

8. If you are updating from older VIDAR SCSI drivers, you will see the message below. Click **Yes**.

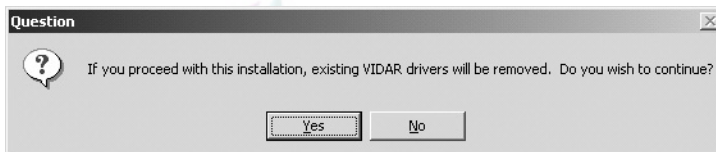

Bayland

baylandtechnologies.com  
telephone: 1-800-801-8432

9. In the **License Agreement** window, activate the **I accept the terms of the license agreement**, then click **Next**.

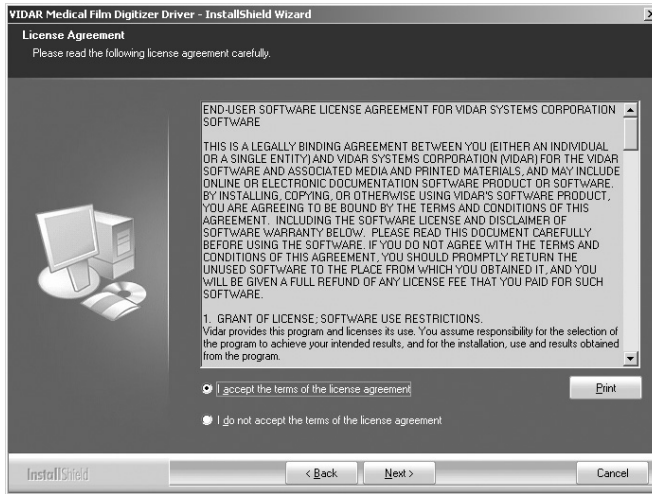

10. In the **Ready to Install the Program** window, click **Install**.

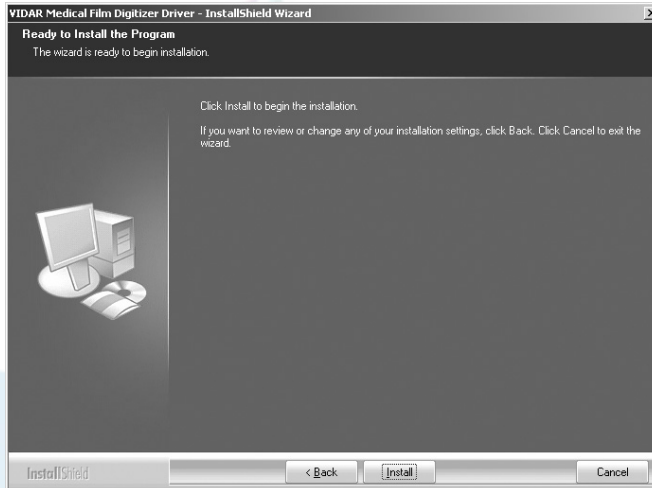

baylandtechnologies.com  
telephone: 1-800-801-8432

10. The **Setup Status** window will appear. Wait while the files are installed.

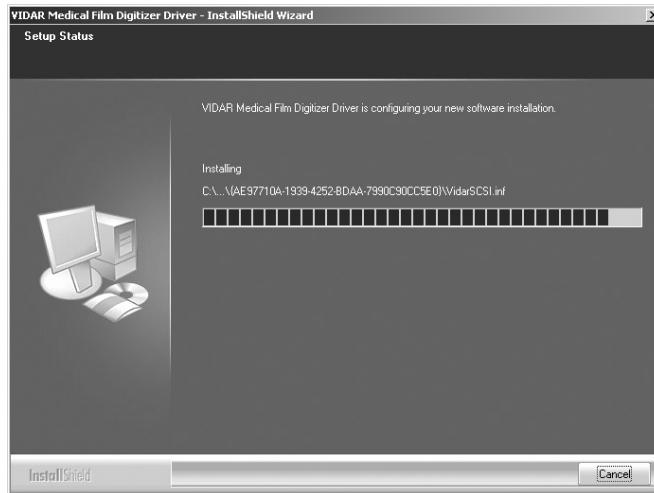

12. InstallShield will indicate that installation is complete. However, drivers are not yet installed.

In the **...Installation Complete** window, activate **No, I will restart my computer later**, then click **Finish**.

13. Shut down the computer. Leave the VIDAR CD in the CD drive.
14. Earlier, you connected VIDAR SCSI cable part number 4270 to the digitizer. Now, attach the 50-pin connector on the other end of that cable to the external port on the SCSI adapter.
15. Turn on the digitizer.
16. Turn on the computer.
17. After Windows loads, the **Found New Hardware** window will appear, indicating that the digitizer is connected to the computer.
18. Next, the **Digital Signature Not Found** window will appear. Click **Yes**.



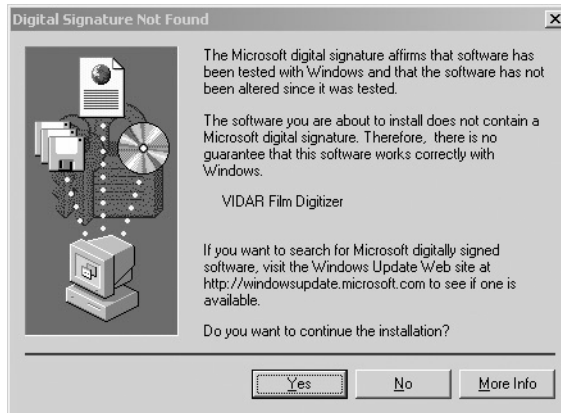

19. Verify that the digitizer drivers are fully installed by checking the device properties. Use the path for your operating system:
  - For Windows™ XP Professional: **Start > Control Panel > Printers and Other Hardware > Scanners and Cameras.**
  - For Windows™ 2000 Professional: **Start > Settings > Control Panel > Scanners and Cameras.**
20. In the device window, right-click **Vidar Film Digitizer**, then click **Properties** in the pop-up menu.
21. In the **VIDAR Film Digitizer Properties** window, click the **VIDAR Properties** tab.

Bayland

baylandtechnologies.com  
telephone: 1-800-801-8432

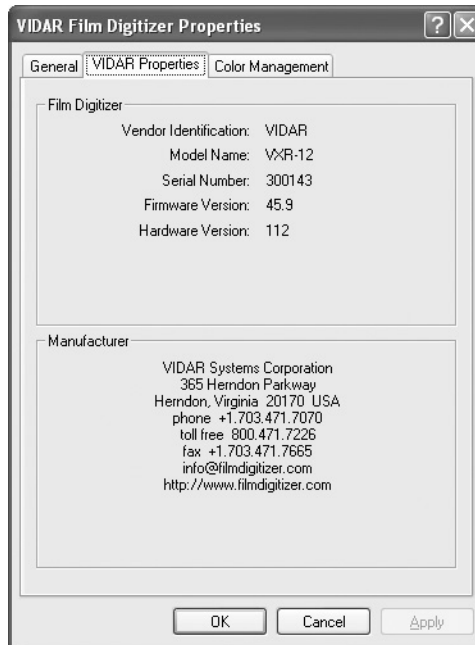

Note that:

- The digitizer will report as “VXR-12” for backward compatibility.
- You may not see the same firmware and hardware version as shown in the window above.
- The serial number will not report if the digitizer was just powered on. Your digitizer’s serial number will be different from the one shown in the example above.

**Note:** The Windows New Hardware Wizard will force you to reinstall the drivers if any of the following occur after driver installation:

- The digitizer is moved to another SCSI card
- The digitizer firmware is changed
- The digitizer is switched to another SCSI ID

The driver files are placed on the local hard disk during digitizer installation, so that the driver CD should not be needed.

BayAreaTechnologies.com  
telephone: 1-800-801-8432

---

**NEXT:** Go to “Updating the VIDAR Toolkit” ➡

---



baylandtechnologies.com  
telephone: 1-800-801-8432

# Installing USB drivers

**Note:** VIDAR digitizers with serial numbers 310000 and higher have USB 2.0 functionality. Some older models have USB ports, but require factory hardware upgrades to operate as USB devices. Contact VIDAR for details.

**Note:** Do not connect the digitizer to the computer until you are prompted during the driver installation process.

## USB interface requirements

- The computer must have a USB **2.0** port. If you are not certain that the computer has a USB 2.0 port, contact its manufacturer. Be aware that the manufacturer may tell you that a USB 2.0 peripheral can be used with a USB 1.1 port. That combination may be possible for other devices, but the operating system will not recognize the VIDAR digitizer if it is connected to a USB 1.1 port.
- If the computer does not have a USB 2.0 port, you may install a USB 2.0 adapter. Adaptec™ ([www.adaptec.com](http://www.adaptec.com)) offers several USB 2.0 adapters; however, VIDAR has only tested Adaptec Model USB2Connect, part number AUA-2000.
- The computer's operating system must be upgraded to the following level:
  - Windows™ XP: Service Pack 1 or higher.
  - Windows™ 2000: Service Pack 4 or higher.Microsoft does not support USB 2.0 on earlier service packs.
- The digitizer must be connected to the computer with a USB 2.0 cable. VIDAR provides an approved USB 2.0 cable (part number 4618) with all USB digitizer orders; this cable has been tested and approved for EMI radiated emissions.

## Updating a previous VIDAR STI driver installation

If older VIDAR STI drivers are installed on this computer, you must first remove them, then perform a clean driver installation.

To remove older drivers:

1. For Windows™ XP Professional: **Start > Control Panel > Printers and Other Hardware > Scanners and Cameras.**  
or  
On a Windows™ 2000 system: **Start > Settings > Control Panel > Scanners and Cameras.**
2. **VIDAR Film Digitizer** should report in the **Devices** window. Click the **Remove** button.
3. Continue in “Installing the USB drivers,” next.



baylandtechnologies.com  
telephone: 1-800-801-8432

## Installing the USB drivers

You will need:

- VIDAR Drivers and Toolkit Installation CD.

**Note:** These instructions have been successfully tested on a wide range of Windows™ 2000 and Windows™ XP systems. In rare instances, you may have difficulty installing the STI driver. If that happens, try again after logging on as Administrator, or as a user with Administrator rights.

1. **Be sure the digitizer is turned OFF, and is NOT connected to the PC.** Wait until you are prompted to connect the digitizer.

**Note:** If the USB cable is connected to the digitizer **before** installing driver software and the hardware wizard is allowed to install the drivers from the CD, you will be prompted to install the CD each time the digitizer is moved to another USB port.

To correct this, the driver software will need to be installed twice. The first time will be done as detailed in steps 1 through 19; the second time will follow the same method with one exception: the installation wizard will recognize that the software has been installed and will give two options prior to installation – Remove or Repair. Select **Repair** and continue with the process. After completing this process, you will no longer need the CD if the digitizer is moved to another USB port.



baylandtechnologies.com  
telephone: 1-800-801-8432

2. Turn on the PC.
3. Insert the **VIDAR Drivers and Toolkit Installation CD** into the CD-ROM. The installer should launch automatically.

If the installer does not launch automatically, double-click the appropriate CD drive icon under **My Computer** in Windows™ Explorer.

4. In the first screen, click **Install Software**.

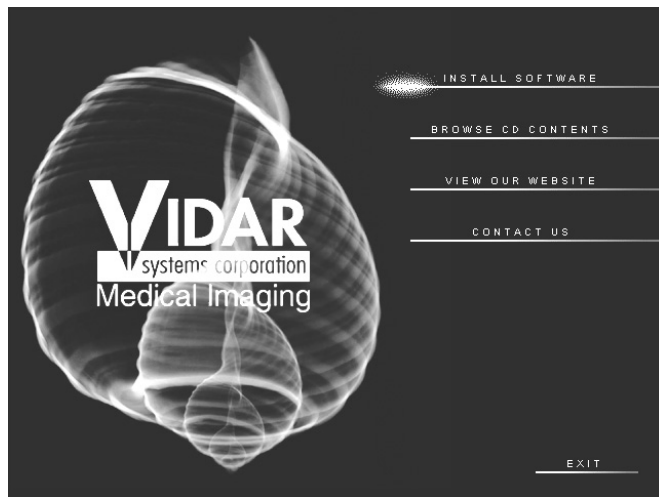

baylandtechnologies.com  
telephone: 1-800-801-8432

5. In the next screen, click **Install Digitizer Driver**.



6. You will see a message that the InstallShield Wizard is starting.
7. In the InstallShield Welcome screen, click **Next**.

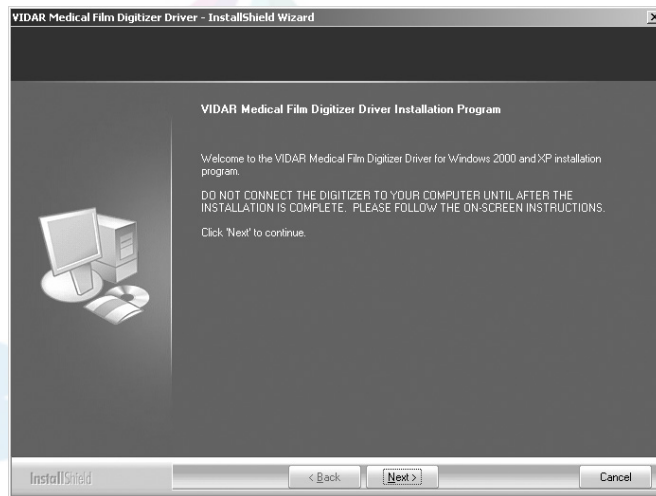

baylandtechnologies.com  
telephone: 1-800-801-8432



8. If you are updating from older VIDAR SCSI drivers, you will see the message below. Click **Yes**.

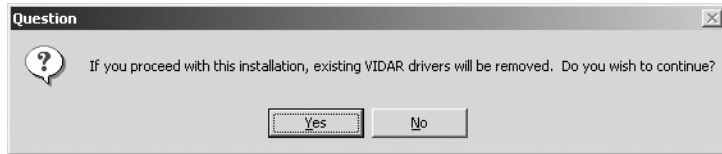

9. In the **License Agreement** window, activate the **I accept the terms of the license agreement**, then click **Next**.

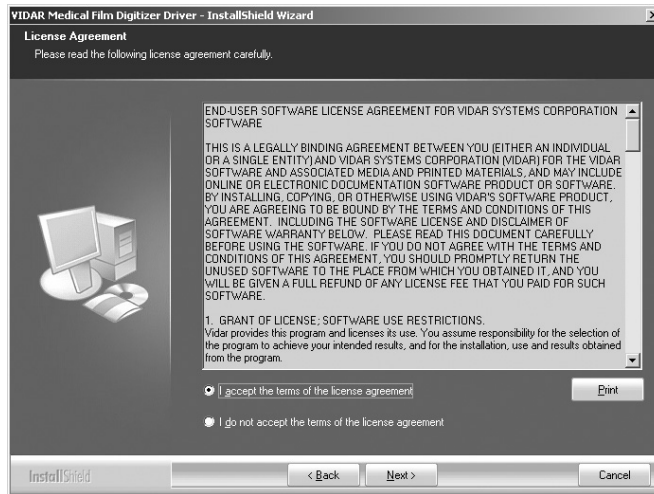

baylandtechnologies.com  
telephone: 1-800-801-8432

10. In the **Ready to Install the Program** window, click **Install**.

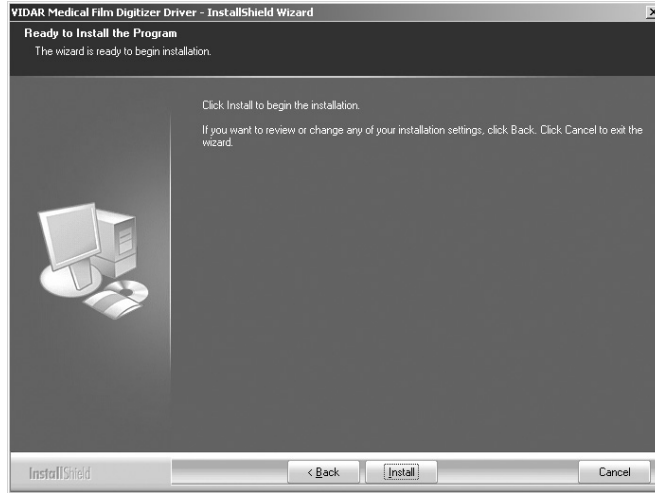

11. The **Setup Status** window will appear. Wait while the files are installed.

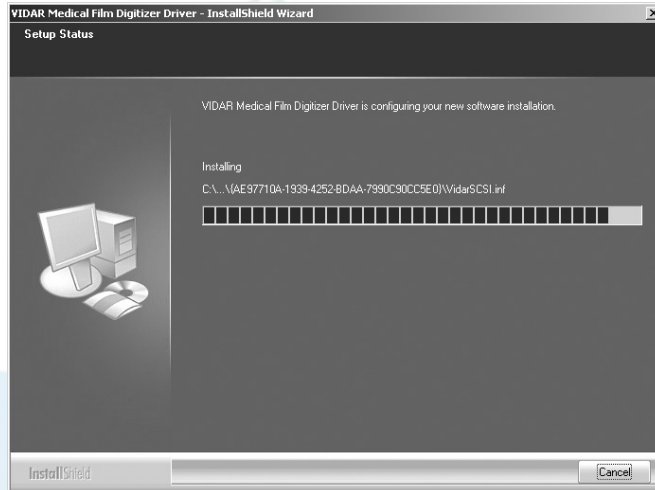

baylandtechnologies.com  
telephone: 1-800-801-8432

13. InstallShield will indicate that installation is complete. However, drivers are not yet installed.

In the **...Installation Complete** window (not shown), activate **No, I will restart my computer later**, then click **Finish**.

14. Connect the digitizer to the computer's USB 2.0 port with a USB 2.0 cable.
15. Shortly after connecting the digitizer to the computer, the **New Hardware Found Wizard** window will appear.
  - If the computer is running Windows™ XP, activate the **Install the software automatically** option, then click **Next**.
  - If the computer is running Windows™ 2000, activate the **Install from a list or specific location** option, then click **Next**. In the next screen (not shown), select the CD drive.



baylandtechnologies.com  
telephone: 1-800-801-8432

16. The wizard will search for the USB driver files.



17. You may see a warning about Windows™ Logo Testing. Click **Continue Anyway**.



baylandtechnologies.com  
telephone: 1-800-801-8432

18. The wizard will indicate that files are being installed. This may take a minute or so to complete.



19. When the wizard is finished installing the driver, click **Finish**.



baylandtechnologies.com  
telephone: 1-800-801-8432

20. Verify that the digitizer drivers are fully installed by checking the device properties. Use the path for your operating system:
  - For Windows™ XP Professional: **Start > Control Panel > Printers and Other Hardware > Scanners and Cameras.**
  - For Windows™ 2000 Professional: **Start > Settings > Control Panel > Scanners and Cameras.**
21. In the device window, right-click **Vidar Film Digitizer**, then click **Properties** in the pop-up menu.



baylandtechnologies.com  
telephone: 1-800-801-8432

22. In the **VIDAR Film Digitizer Properties** window, click the **VIDAR Properties** tab.

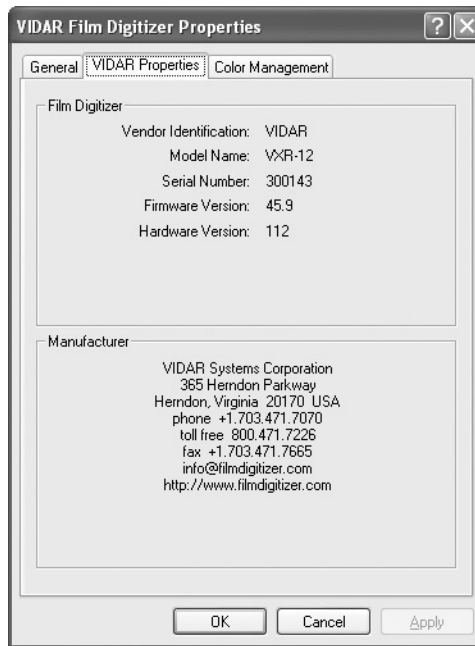

Note that:

- The digitizer will report as “VXR-12” for backward compatibility.
- You may not see the same firmware and hardware version as shown in the window above.
- The serial number will not report if the digitizer was just powered on. Your digitizer’s serial number will be different from the one shown in the example above.

---

**NEXT:** Go to “Updating the VIDAR Toolkit” ⇨

---

baylandtechnologies.com  
telephone: 1-800-801-8432

# Updating the VIDAR Toolkit

---

## IMPORTANT

The scanning application must be installed before performing the Toolkit DLL Update.

The Update Toolkit DLL feature on the VIDAR Drivers and Toolkit CD updates the scanning application with the current VIDAR Toolkit Dynamic Link Library (DLL). Check with the scanning application vendor to ensure that the scanning application has tested *vscsi32.dll*, version 4.1.81.

**WARNING:** VIDAR has validated the STI driver and replacement of *vscsi32.dll* with all supported VIDAR digitizers on both Windows™ 2000 and Windows™ XP systems using several third party software applications. No bugs or problems were identified during validation testing. However, you must check with your system integrator or scanning software vendor to verify that they support the replacement of VIDAR's *vscsi32.dll*.

1. Insert the **VIDAR Drivers and Toolkit Installation CD** into the CD-ROM. The installer should launch automatically.

If the installer does not launch automatically, double-click the appropriate CD drive icon under **My Computer** in Windows™ Explorer.

baylandtechnologies.com  
telephone: 1-800-801-8432



2. In the first screen, click **Install Software**.



3. In the next screen, click **Update Toolkit DLL**.



baylandtechnologies.com  
telephone: 1-800-801-8432

4. A DOS window will open. Wait while the files are updated.

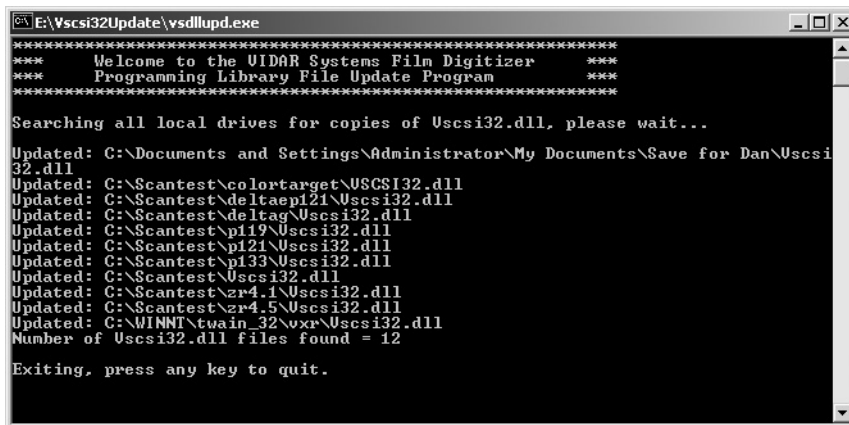

```

E:\Vscsi32Update\ysdllupd.exe
*****
*** Welcome to the VIDAR Systems Film Digitizer ***
*** Programming Library File Update Program ***
*****
Searching all local drives for copies of Uscsi32.dll, please wait...

Updated: C:\Documents and Settings\Administrator\My Documents\Save for Dan\Uscsi32.dll
Updated: C:\Scantest\colortarget\USCSI32.dll
Updated: C:\Scantest\deltaep121\Uscsi32.dll
Updated: C:\Scantest\deltaag\Uscsi32.dll
Updated: C:\Scantest\p119\Uscsi32.dll
Updated: C:\Scantest\p121\Uscsi32.dll
Updated: C:\Scantest\p133\Uscsi32.dll
Updated: C:\Scantest\Uscsi32.dll
Updated: C:\Scantest\zr4.1\Uscsi32.dll
Updated: C:\Scantest\zr4.5\Uscsi32.dll
Updated: C:\WINNT\winain_32\usp\Uscsi32.dll
Number of Uscsi32.dll files found = 12

Exiting, press any key to quit.

```

5. When you see the message “Exiting, press any key to quit,” press any key or close the window by clicking the X in the upper right corner.
6. Remove the VIDAR Drivers and Toolkit Installation CD.

**IMPORTANT:** You will need to update the toolkit DLL if you:

- Uninstall or reinstall the drivers.
- Upgrade the digitizer firmware.
- Replace the digitizer with another one having different firmware.
- Reinstall the scanning application.
- Install the digitizer and scanning application on another computer.

**NEXT:** Go to the operating chapter for your digitizer ➡

baylandtechnologies.com  
telephone: 1-800-801-8432



baylandtechnologies.com  
telephone: 1-800-801-8432



# Advantage Series Operating Guide

# Bayland

baylandtechnologies.com  
telephone: 1-800-801-8432

**VIDAR**  
systems corporation  
Medical Imaging

# Operating

## DIAGNOSTICPRO™ Advantage and DOSIMETRYPRO™ Advantage

### About digitizers and film sizes

This section describes important differences between the DIAGNOSTICPRO™ Advantage and DOSIMETRYPRO™ Advantage.

#### DIAGNOSTICPRO™ Advantage specifications

Nominal resolution	Pixels (14"x17" film)	Spot size (µm)	DPI	Line pairs per mm	Digitizing speed
1k x 1.25k	1008 x 1124	340	75	1	12.2 sec
2k x 2.5k*	2002 x 2431	170	150	3	12.2 sec
4k x 5k	3990 x 4845	85	300	6	24.4 sec

#### Mammography film: 18cm x 24cm

4k x 5k	4104 x 5472	44	570	11	27.4 sec
---------	-------------	----	-----	----	----------

\*ACR Standard for Teleradiology Guidelines [Revision 35 (1998)] recommends 2.5 line pairs/mm minimum

**Scan modes** 32-bit mapped to 12-bit and 8-bit grayscale outputs

**Film sizes**  
 (manual feed) Width: 8" to 14" (20.3cm to 35.6cm)  
 Length: 8" to 51"† (20.3cm to 129.5cm)  
 Thickness: 0.006" to 0.010" (0.15mm to 0.51mm)  
 †Longer films require user support during feeding, and a scanning application that handles long films

**Auto film feeder** Standard 25-film capacity (mixed sizes, no presorting)  
 "Light box loading": head-up, normal reading, left justified  
 Width: 8" to 14" (20.3cm x 35.6cm)  
 Length: 8" to 17" (20.3cm x 43.2cm)  
 Thickness: 0.006" to 0.010" (0.15mm to 0.51mm)

baylandtechnologies.com  
 telephone: 1-800-801-8432

## DOSIMETRYPRO™ Advantage specifications

Nominal resolution	Pixels (14"x17" film)	Spot size (µm)	DPI	Line pairs per mm	Digitizing speed
1k x 1.25k	997 x 1211	356	71.25	1.4	12.2 sec
2k x 2.5k*	1995 x 2422	178	142.5	2.8	12.2 sec
4k x 5k	3990 x 4845	89	285	5.6	24.4 sec

\*ACR Standard for Teleradiology [Revision 35 (1998)] recommends 2.5 line pairs/mm minimum

**Scan modes** 32-bit mapped to 12-bit and 8-bit grayscale outputs

**Film sizes** (manual feed)  
 Width: 8" to 14" (20.3cm to 35.6cm)  
 Length: 8" to 51"† (20.3cm to 129.5cm)  
 Thickness: 0.006" to 0.010" (0.15mm to 0.51mm)  
 †Longer films require user support during feeding, and a scanning application that handles long films

**Auto film feeder** Standard 25-film capacity (mixed sizes, no presorting)  
 "Light box loading": head-up, normal reading, left justified  
 Width: 8" to 14" (20.3cm x 35.6cm)  
 Length: 8" to 17" (20.3cm x 43.2cm)  
 Thickness: 0.006" to 0.010" (0.15mm to 0.51mm)



baylandtechnologies.com  
 telephone: 1-800-801-8432

## About films

The film digitizer handles standard radiograph films up to 14" x 17" (35.5cm x 43cm).

You can feed multiple films (up to 25), and you can mix film sizes ranging from 8" x 10" (20.3cm x 24.5cm) to 14" x 17" (35.5cm x 43cm) in one stack—as long as you follow the rules below.

**IMPORTANT:** Remove stickers, tape, staples, paper clips, etc. from films before scanning. These may cause serious film feeding problems and may damage the digitizer's internal mechanisms. **Failure to remove extraneous items from films will void your warranty.**

Load films just as you would view them on a light box, with these qualifications:

- Films less than 8" wide will not be detected by the digitizer's film sensor, and therefore will not be staged or digitized.

**CAUTION:** Films smaller than 8" x 8" can fall into the internal optics box and cause damage not covered by your warranty.

- Do not load films more than 17" (43.2cm) long in the auto feeder. (See "Digitizing a single film," later in this chapter, when loading films longer than 17".)



Bayland

baylandtechnologies.com  
telephone: 1-800-801-8432

## Basic operating instructions

1. Turn on the film digitizer and wait for all three LEDs to turn green.

**Note:** Always turn on the film digitizer before turning on the computer. This enables the computer to recognize the digitizer.

**Note:** Several minutes are required for the digitizer to carry out its internal diagnostics and establish communications with the scanning application. These activities must be completed before you can load film into the digitizer.

2. Turn on the computer.
3. Launch the scanning application.

**IMPORTANT:** Remove stickers, tape, staples, paper clips, etc. from films before scanning. These may cause serious film feeding problems. Failure to remove extraneous items from films will void your warranty.

4. If you will be digitizing films 17" (43.2cm) or longer, raise the film support bar.
5. Load the film.

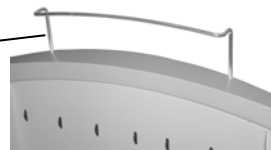

How you load the film depends on whether you are digitizing one film or multiple films. See the next pages for details.

**CAUTION:** X-ray images displayed on a computer monitor are representative only. A variety of factors influence image density and size—including monitor luminance and calibration, window and level settings, zoom level, and dimensional and grayscale inaccuracies resulting from build-up of tolerances in the digitizer, display board and computer. For this reason, special precautions must be exercised (e.g., calibrating the software ruler and computer monitor) when taking measurements from digitized images. Please refer to the user's manual for your digitizing software for more information.



## Digitizing a single film

### Options for digitizing single films

There are two ways to scan a single film:

- By manually inserting the film behind the blue bar (as described in this section), or
- By treating the single film as a batch of one (if the scanning application supports this approach); for instructions, see “Scanning multiple films” (next section in this manual).

The digitizer cannot feed films smaller than 8" wide x 8" long (20.3cm wide x 20.3cm long).

1. Hold the film in front of you as you would view it on a light box.
2. Align the left edge of the film with the film guide on the left of the feeder.
3. Place the film into the slot **BEHIND the blue bar**.

*The blue bar has a lip and a groove on the top edge of the digitizer where the feeder is attached. Place a single film directly behind the blue bar.*



When the digitizer senses the film, it automatically stages the film in preparation for digitizing. The film will first move down, then up. This is normal operation.

**CAUTION:** If the film is not staged properly, do not manually pull the film out of the digitizer. Instead, use the scanning application's EJECT command to remove the film.

*continued*

baylandtechnologies.com  
telephone: 1-800-801-8432

**Note:** When a film has been staged, it is in the digitizer's light path. The ADC (Automatic Digitizer Calibration) feature requires that the light path be clear of the film for proper background calibration of the digitizer. The digitizer will automatically adjust the film's position to properly proceed with ADC. Depending on the location of the film's leading or trailing edge, and the length of time the film has been blocking the light path, the film will be: a) pushed up, or b) pushed down.

4. Using your scanning software, execute the **Scan** command.

**Note:** Proper orientation of the film during loading depends on the scanning application program you are using. Some scanning programs rotate images 180° for display. If images appear upside down, you may be able to set the default orientation in the scanning application. If this option isn't available, then insert films into the digitizer upside down, as shown here.

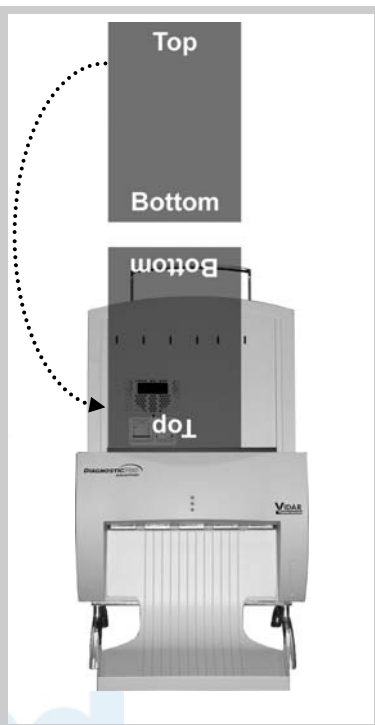

Bayland

baylandtechnologies.com  
telephone: 1-800-801-8432

## Digitizing multiple films

**CAUTION: Do not load more than 25 films at one time.**

1. Hold the film stack in front of you as you would view it on a light box.

Films at the back of the stack are digitized first.

**Note:** The digitizer cannot feed films smaller than 8" wide x 8" long (20.3cm wide x 20.3cm long). When loading small films, the vertical dimension must be at least 8" (20.3cm).



2. Align the left edge of the film stack with the film guide on the left edge of the feeder.
3. Place the film stack **IN the groove in the blue bar.**

*The blue bar has a lip and a groove on the top edge of the digitizer where the feeder is attached. Place a single film directly behind the blue bar.*

**Note:** If you are digitizing a single film, place the film **BEHIND the blue bar.**

*continued*

baylandtechnologies.com  
telephone: 1-800-801-8432

**Note:** When a film has been staged, it is in the digitizer's light path. The ADC (Automatic Digitizer Calibration) feature requires that the light path be clear of the film for proper background calibration of the digitizer. The digitizer will automatically adjust the film's position to properly proceed with ADC. Depending on the location of the film's leading or trailing edge, and the length of time the film has been blocking the light path, the film will be: a) pushed up, or b) pushed down.

4. Using your scanning software, execute the **Scan** command.

**Note:** During extended batch scans (more than 5 films), the digitizer may pause periodically to recalibrate. This is normal operation.

**Note:** Proper orientation of the film during loading depends on the scanning application program you are using. Some scanning programs rotate images 180° for display. If images appear upside down, you may be able to set the default orientation in the scanning application. If this option isn't available, then insert films into the digitizer upside down, as shown here.

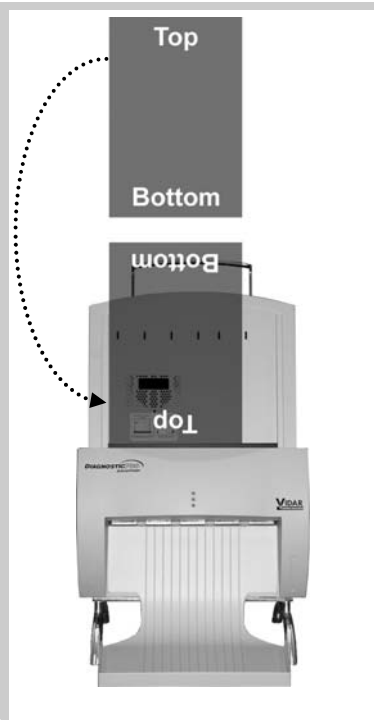

**Bayland**  
technologies

baylandtechnologies.com  
telephone: 1-800-801-8432



baylandtechnologies.com  
telephone: 1-800-801-8432

# Operating

## CADPRO™ Advantage

### Film sizes and scanning specifications

#### 18cm long x 24cm wide mammography film (landscape orientation)

Pixels	Spot size ( $\mu\text{m}$ )	DPI	Line pairs per mm	Digitizing speed
4032 x 5376	44	570	11	~30 sec

#### 30cm long x 24cm wide mammography film (portrait orientation)

Pixels	Spot size ( $\mu\text{m}$ )	DPI	Line pairs per mm	Digitizing speed
6720 x 5376	44	570	11	~50 sec

<b>Scan modes</b>	32-bit mapped to 16-bit and 12-bit grayscale outputs
<b>Film sizes</b>	Fixed width: 24cm Length: 18cm or 30cm Thickness: 0.006" to 0.010" (0.15mm to 0.51mm)
<b>Auto film feeder</b>	50 or 100-film capacity (mixed sizes) "Light box loading": head-up, normal reading

baylandtechnologies.com  
telephone: 1-800-801-8432

## About films

The film digitizer handles standard 18cm x 24cm and 24cm x 30cm mammography films.

You can feed multiple films (up to 50 or 100, depending on the feeder), and you can mix film sizes.

**IMPORTANT:** Remove stickers, tape, staples, paper clips, etc. from films before scanning. These may cause serious film feeding problems and may damage the digitizer's internal mechanisms. **Failure to remove extraneous items from films will void your warranty.**

To prepare films for digitizing:

- Stack each group of films according to the sequence specified by the CAD system manufacturer. A typical sequence is shown below.
- Place a separator in each group. Use separators approved by the CAD system manufacturer.

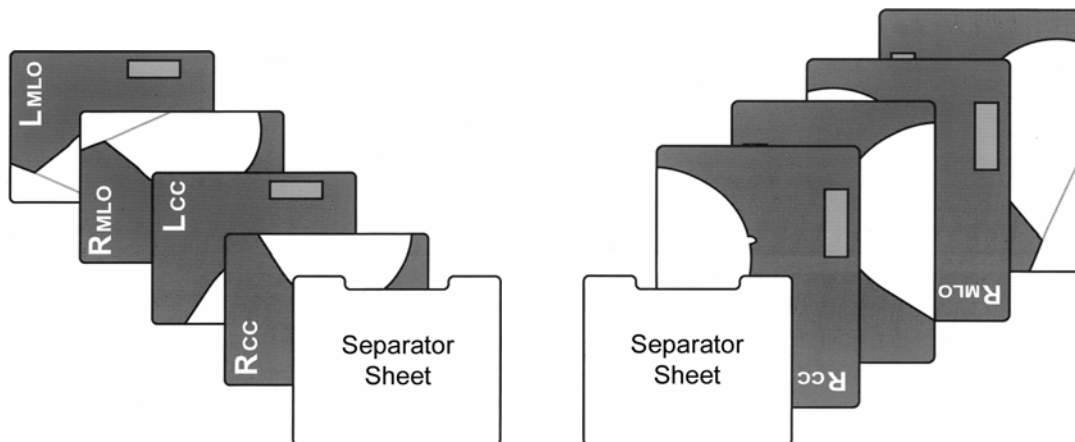

18cm long x 24cm wide film stack

30cm long x 24cm wide film stack



**Bayland**  
technologies

baylandtechnologies.com  
telephone: 1-800-801-8432

## Operating instructions

1. Turn on the film digitizer and wait for all three LEDs to turn green.

**Note:** Always turn on the film digitizer before turning on the computer. This enables the computer to recognize the digitizer.

**Note:** Several minutes are required for the digitizer to carry out its internal diagnostics and establish communications with the scanning application. These activities must be completed before you can load film into the digitizer.

2. Turn on the computer.
3. Launch the scanning application.

**IMPORTANT:** Remove stickers, tape, staples, paper clips, etc. from films before scanning. These may cause serious film feeding problems. **Failure to remove extraneous items from films will void your warranty.**

**CAUTION:** X-ray images displayed on a computer monitor are representative only. A variety of factors influence image density and size—including monitor luminance and calibration, window and level settings, zoom level, and dimensional and grayscale inaccuracies resulting from build-up of tolerances in the digitizer, display board and computer. For this reason, special precautions must be exercised (e.g., calibrating the software ruler and computer monitor) when taking measurements from digitized images. Please refer to the user's manual for your digitizing software for more information.

*continued*



**Bayland**  
technologies

baylandtechnologies.com  
telephone: 1-800-801-8432



4. Hold the stack in front of you as you would view it on a light box.
5. Slide the stack into the feeder, between the guides. **Do not overfill the feeder:**
  - The 50 sheet feeder can hold up to 50 sheets at a time.
  - The 100 sheet feeder can hold up to 100 sheets at a time.



6. Using your scanning software, execute the **Scan** command.
7. Monitor the exit tray, and remove films periodically to prevent it from overflowing. The exit tray can hold up to 100 films. If it becomes overfilled, films may be damaged or jam in the digitizer.



Bayland

baylandtechnologies.com  
telephone: 1-800-801-8432



## Advantage Series Other Information

Bayland

baylandtechnologies.com  
telephone: 1-800-801-8432

**VIDAR**  
systems corporation  
Medical Imaging

# Preventive maintenance

## Cleaning the Auto-Feed Roller

[DIAGNOSTICPRO™ Advantage and DOSIMETRYPRO™ Advantage only]

After extensive use, dust or lint particles may build up on the Auto-Feed Roller. VIDAR recommends cleaning the roller at least twice per year.

Loop a piece of light adhesive tape (such as Scotch® Magic™ Tape) around your fingers with the adhesive side out, then gently pat the roller. Pat and turn the roller until its entire surface is clean.

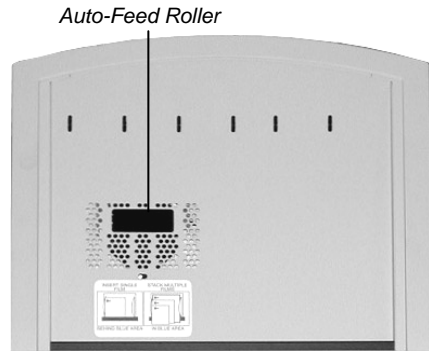

### CAUTION:

- **Do not** use any type of cleaning solvent on the feed roller and idler wheels, as this could damage these components and cause improper operation.
- **Do not** use tape with a strong adhesive, such as packing tape or strapping tape.
- **Do not** use tape requiring the adhesive to be wetted, such as brown paper packing tape.



**Bayland**  
technologies

baylandtechnologies.com  
telephone: 1-800-801-8432

## Cleaning the Auto-Feed Roller and Suction Cups [CADPRO™ Advantage only]

After extensive use, dust or lint particles may build up on the Auto-Feed Roller and Suction Cups, and they must be cleaned to maintain reliable film feeding. VIDAR recommends cleaning the Auto-Feed Roller and Suction Cups at least twice per year. During cleaning, inspect the Suction Cups for wear.

1. Turn off the digitizer using the switch on the rear panel.
2. Remove the Film Guide from the feeder by loosening four screws. Loosen each screw a few turns, then move to the next screw. Repeat until the Film Guide is freed from the feeder.

**Note:** The screws are captive, but will come entirely out if unscrewed too far, and could then fall into the digitizer base. Be careful not to unscrew them from their captive locations. Removal of screws or other items from the inside of the digitizer is not covered under your warranty.

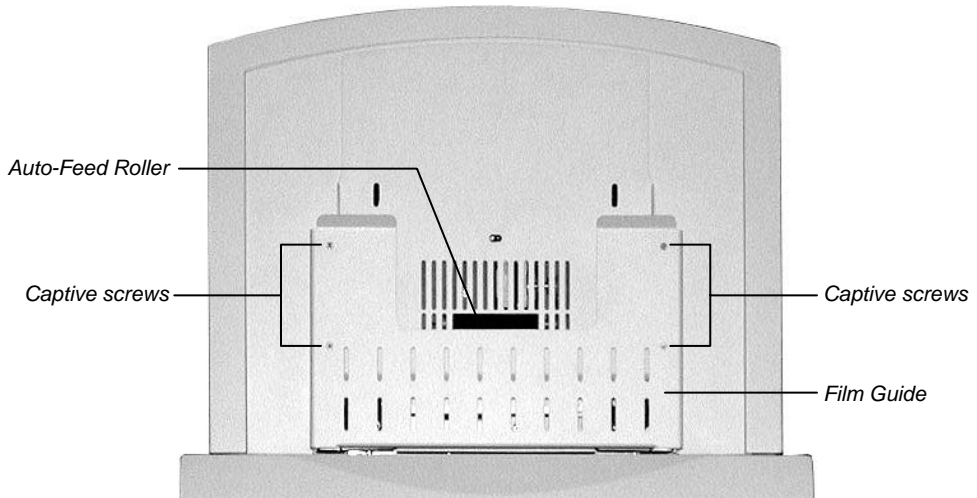

**Bayland**  
technologies

baylandtechnologies.com  
telephone: 1-800-801-8432

3. Remove residue from the Auto-Feed Roller: Loop a piece of light adhesive tape (such as Scotch® Magic™ Tape) around your fingers with the adhesive side out, then gently pat the roller. Pat and turn the roller until its entire surface is clean.
4. Gently pull the Suction Cups forward.
5. Examine the Suction Cups. If you see cracks or irregularities, you should replace the Suction Cups to prevent film feeding problems. Replacement Suction Cups (p/n 4533-001) can be ordered from VIDAR.
6. Clean the Suction Cups using an isopropyl wipe (VIDAR part number 4100).

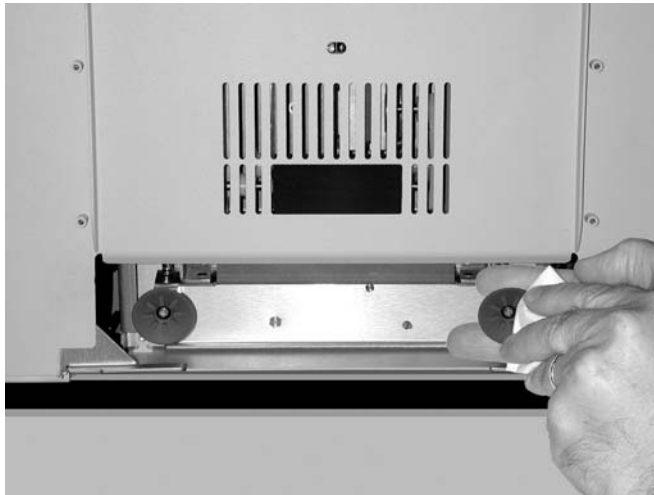
**CAUTION:**

- **Do not** use any type of cleaning solvent on the feed roller, as this could damage it and cause improper operation.
- **Do not** use tape with a strong adhesive, such as packing tape or strapping tape.
- **Do not** use tape requiring the adhesive to be wetted, such as brown paper packing tape.

8. Secure the faceplate to the feeder with the four captive screws.  
**Tighten the screws a little at a time, in the order shown here:**

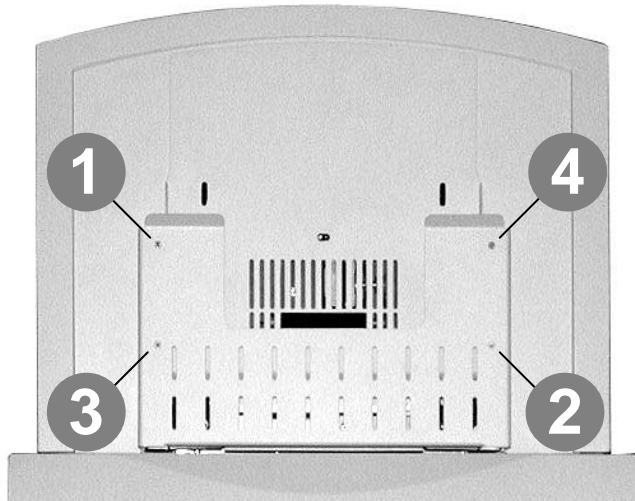

baylandtechnologies.com  
telephone: 1-800-801-8432

## Cleaning the diffuser [all Advantage models]

If you notice streaks (vertical artifacts) in images, you should clean the diffuser.

1. Turn off the digitizer. **Allow 10 to 15 minutes for the bulb cartridge to cool to a comfortable temperature before removing it.**
2. Open the door on the side of the digitizer base:



**Note:** The door has a “door open” sensor. When the door is open, all processes—including calibration and scanning—will stop.



3. Grasp the top and bottom of the lamp cartridge, then pull it out.



**CAUTION:** Do not touch the diffuser material with your fingers.

4. Place the lamp cartridge on a flat surface with the diffuser facing up.
5. Clean the diffuser using a lint-free wipe (VIDAR part number 15194). **Wipe in one direction only. Don't wipe back and forth.**

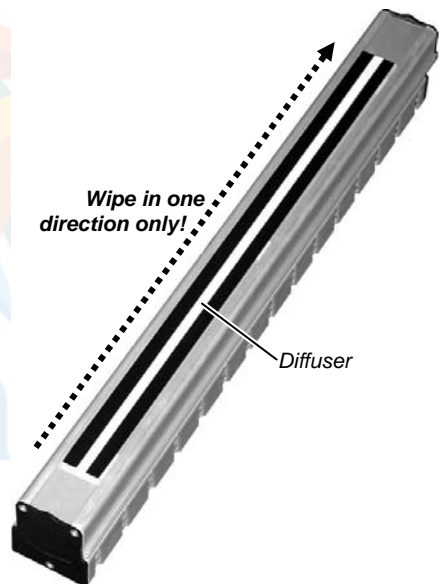

Bayla

baylandtechnologies.com  
telephone: 1-800-801-8432



6. Insert the lamp cartridge into the digitizer base:

- The diffuser must face the rear of the digitizer base.
- The end of the lamp cartridge with the white connector goes in first.
- Ensure the slots along the top and bottom of the cartridge align with the slides in the digitizer (see illustration at right).
- When the cartridge is nearly all the way in, push it firmly until you feel the connector snap into place.

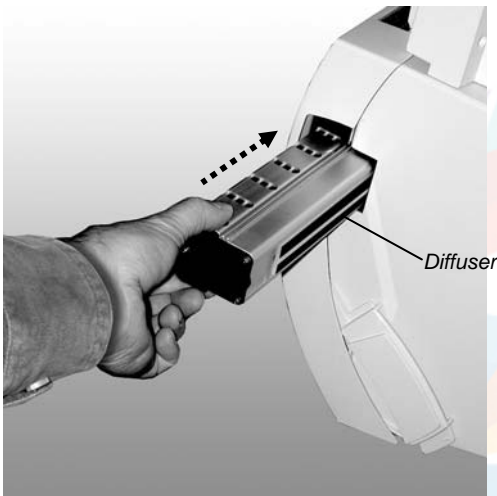
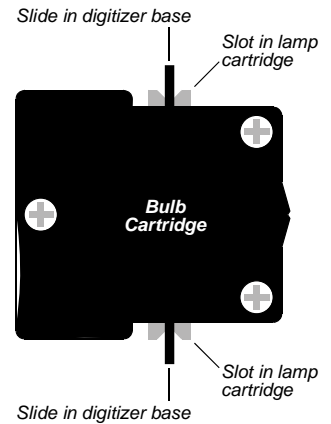

*Slide cartridge in...*



*then push to seat connector*

baylandtechnologies.com  
telephone: 1-800-801-8432

7. Close the door on the side of the digitizer base. Be sure the door closes fully.

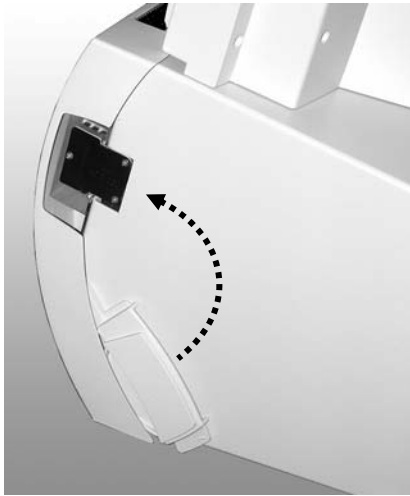

8. Turn on the digitizer. The digitizer will recalibrate to the cleaned diffuser.



baylandtechnologies.com  
telephone: 1-800-801-8432

## Replacing the lamp cartridge [all Advantage models]

Follow the instructions in “Cleaning the diffuser,” earlier in this chapter, but work with the new lamp cartridge in steps 4, 5 and 6.

VIDAR recommends replacing the lamp cartridge once per year as part of the scheduled preventive maintenance on the film digitizer. Preventive maintenance is not covered under warranty. (Only failures during the published warranty period are covered by warranty replacement. Failures must be confirmed by running VIDAR’s ScanInfo 5.2 diagnostic software. The software generates a report showing light values indicative of lamp performance. You can request a copy of the ScanInfo program from VIDAR Technical Support.)

**Contact VIDAR Technical Support** if you have any questions about installing or using your VIDAR film digitizer:

Phone: +1.800.471.SCAN (+1.800.471.7226)  
+1.703.471.7070 outside the U.S.

E-mail: [medtech@vidar.com](mailto:medtech@vidar.com)







[baylandtechnologies.com](http://baylandtechnologies.com)  
telephone: 1-800-801-8432

# Troubleshooting

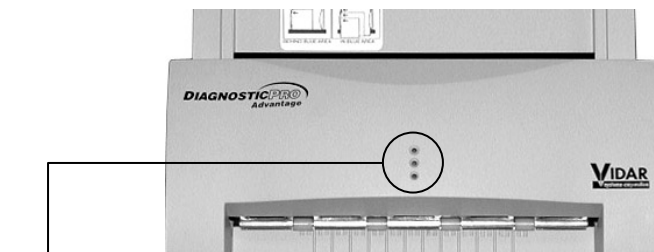
## Reading the LEDs

Three LEDs on the front of the digitizer provide operating information.



	Location	Function	Normal state
	Top LED	Feeder status	Solid green
	Center LED	Digitizer status	Solid green, but slow flashing when digitizer is busy
	Bottom LED	Power status	Solid green

Tables on the next three pages explain all LED states.

baylandtechnologies.com  
telephone: 1-800-801-8432

## Top LED: feeder status

LED state	Digitizer condition	Corrective action
Solid green	Ready	None. The feeder is ready to operate.
Off	ERROR: no feeder attached	<ol style="list-style-type: none"> <li>1. Turn off digitizer.</li> <li>2. Remove feeder.</li> <li>3. Inspect electrical connector and screws on bottom of feeder.</li> </ol>
Fast flashing green	ERROR: unknown feeder attached	Check feeder: <ol style="list-style-type: none"> <li>1. Turn off digitizer.</li> <li>2. Remove feeder.</li> <li>3. Inspect electrical connector and screws on bottom of feeder.</li> </ol>
Slow flashing green	BUSY: film is staging	None. This is normal operation.
Fast flashing green	ERROR: film staging problem	Eject film by clicking the eject button in the scanning application.



baylandtechnologies.com  
telephone: 1-800-801-8432

## Center LED: digitizer status

LED state	Digitizer condition	Corrective action
Solid green	Ready	None. The digitizer is ready to accept commands from the scanning application.
Slow flashing green	BUSY: normalizing	None. This is normal operation. The LED will flash slowly during initial calibration after power is applied, and when the scanning application initiates a calibration.
Slow flashing green	BUSY: tracking (ADC)	None. This is normal operation. The LED will flash periodically when the digitizer is idle. Automatic Digitizer Calibration (ADC) is independent of the scanning application.
Slow flashing green	BUSY: staging film	None. This is normal operation. The LED will flash slowly while the digitizer is staging the film.
Slow flashing green	BUSY: Positioning film	None. This is normal operation. The LED will flash slowly while the scanning application is positioning the film.
Slow flashing green	BUSY: digitizing film	None. This is normal operation. The LED will flash slowly while a film is being digitized.
Slow flashing green	BUSY: ejecting film	None. This is normal operation. The LED will flash slowly while the scanning application is ejecting the film.
Off	ERROR	<ol style="list-style-type: none"> <li>1. Make certain power is supplied to the digitizer, and that the digitizer power switch is on.</li> <li>2. If problem persists, get qualified technical help (see "In case of difficulty," later in this chapter).</li> </ol>



# Bayland

baylandtechnologies.com  
telephone: 1-800-801-8432

**Bottom LED: power status**

LED state	Digitizer condition	Corrective action
Solid green	Ready	None.
Fast flashing green	ERROR: DSP not communicating	Get qualified technical help (see “In case of difficulty,” later in this chapter).
Fast flashing green	ERROR: unknown ballast	Get qualified technical help (see “In case of difficulty,” later in this chapter).
Off	ERROR	<ol style="list-style-type: none"><li>1. Make certain power is supplied to the digitizer, and that the digitizer power switch is on.</li><li>2. If problem persists, get qualified technical help (see “In case of difficulty,” later in this chapter).</li></ol>



baylandtechnologies.com  
telephone: 1-800-801-8432

## In case of difficulty

How to use this section:

1. Look through the left columns to find a description of the problem you are having.
2. Follow the instructions (in order) in the “Corrective action” column. If the one corrective action doesn’t solve the problem, then carry out the next corrective action.
3. When the instruction is “Get qualified technical help,” then:
  - a. Contact your system integration specialist (the company or person that installed your VIDAR film digitizer).
  - b. If your system integration specialist isn’t available, then contact VIDAR Customer Support (medtech@vidar.com). Please record system information and digitizer serial number before calling, and have it available when calling.

**Tip:** Check [www.filmdigitizer.com](http://www.filmdigitizer.com) for current troubleshooting information, tools and software updates.

Symptom	Corrective action
Can't turn digitizer on or off. Can't find power switch.	The on/off switch is located on the rear of the digitizer body. Look at the digitizer from the rear to see the switch.
Streaks in image	Clean lamp diffuser (see “Cleaning the diffuser” in the “Cleaning and maintaining” chapter, earlier in this manual).

*continued*



Bayland

baylandtechnologies.com  
telephone: 1-800-801-8432



Symptom	Corrective action
Bottom LED (power status) is off.	<p>Ensure wall outlet is providing AC power: obtain another electrical device known to be working, and plug it into that AC wall outlet.</p> <ul style="list-style-type: none"> <li>■ If other device doesn't work, AC power is not available at that wall outlet. Get help from building services.</li> <li>■ If other device does work, AC power is available from that outlet.</li> </ul>
Film starts and stops during scanning.	<ol style="list-style-type: none"> <li>1. Increase memory allocation for scanning software. (Especially if scanning at high resolutions, memory allocation must be sufficient to accept data stream from digitizer.)</li> <li>2. If scanning to disk, ensure sufficient space is available on disk drive.</li> <li>3. Ensure PC has enough memory available to support scanning application. Close applications not needed for image acquisition from digitizer.</li> <li>4. If problem persists, get qualified technical help.</li> </ol>
Digitizer stops scanning and PC locks up.	<ol style="list-style-type: none"> <li>1. Reset entire system. Remember that SCSI protocol requires that digitizer be powered before PC. <ol style="list-style-type: none"> <li>a. Turn digitizer off.</li> <li>b. Shut down PC.</li> <li>c. Turn digitizer on.</li> <li>d. After digitizer all three digitizer LEDs turn solid green, turn on PC.</li> </ol> </li> <li>2. Launch scanning software on PC, then try scanning again. If problem persists, get qualified technical help.</li> <li>3. Check for correct device driver installation.</li> </ol>

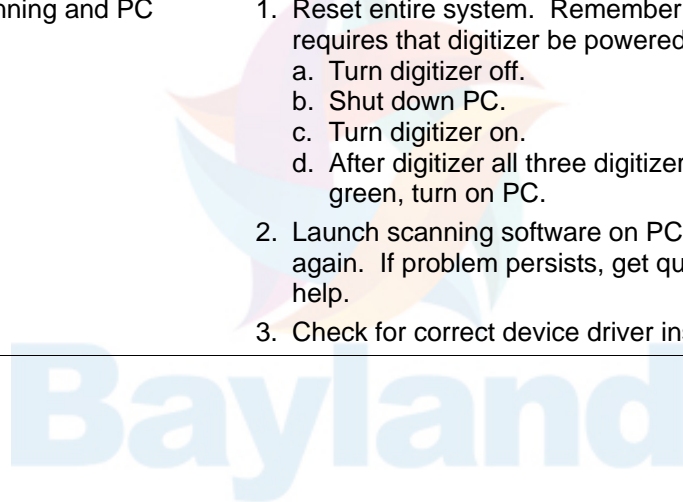

Bayland

*continued*

baylandtechnologies.com  
telephone: 1-800-801-8432

Symptom	Corrective action
Digitizer was working properly, but after installing (or reinstalling) the scanning application there are Toolkit errors or the digitizer is not detected on the SCSI bus.	<ol style="list-style-type: none"> <li>1. If you installed a new scanning application, or if you reinstalled the existing application, the older Toolkit (<i>vscsi32.dll</i>) may have been installed. Run the VIDAR Drivers and Toolkit Installation CD (see appropriate section in the “Installing device drivers” chapter).</li> <li>2. If problem persists, contact <a href="mailto:medtech@vidar.com">medtech@vidar.com</a>.</li> </ol>
Digitizer is not listed in Windows™ Control Panel under Scanners and Cameras.	<ol style="list-style-type: none"> <li>1. Update to STI drivers. See “Computers with Windows™ 2000 and Windows™ XP” in the “Installing device drivers” chapter.</li> <li>2. Check all SCSI cables and connectors.</li> </ol>
Digitizer is not detected on SCSI bus.	<ol style="list-style-type: none"> <li>1. Set up SCSI card. See the “Installing SCSI hardware” chapter.</li> <li>2. Check all SCSI cables and connectors.</li> </ol>
Auto Feeder does not reliably feed films.	<ol style="list-style-type: none"> <li>1. Clean the lift roller on the Feeder.</li> <li>2. CadPro only: Clean the Suction Cups inside the feeder (see “Cleaning the Auto-Feed Roller and Suction Cups” in the “Preventive maintenance” chapter). Be sure Suction Cups are not loose.</li> </ol>
Computer does not recognize the digitizer when it is connected through a USB cable.	<p>VIDAR firmware does not support USB 1.1. The digitizer will not be detected by the host computer if it is connected to a USB 1.1 port. The digitizer must be connected to a USB 2.0 port.</p> <ul style="list-style-type: none"> <li>■ Check the operating system to ensure the latest service pack is installed (Windows™ XP must have Service Pack 1 or higher; Windows™ 2000 must have Service Pack 4 or higher). Microsoft does not support USB 2.0 in older service packs.</li> <li>■ If the computer does not have a USB 2.0 port, install a USB 2.0 adapter. Adaptec™ (<a href="http://www.adaptec.com">www.adaptec.com</a>) offers several USB 2.0 adapters. VIDAR has tested Adaptec’s USB2Connect, p/n AUA-2000.</li> </ul>
Windows XP does not recognize the USB-connected film digitizer when another USB scanner is connected to the system.	<p>Disconnect the other scanner from the system. Windows XP (SP1 and SP2) supports only one scanner per system.</p>

# Weights and dimensions

## Shipping weight and dimensions

Shipping dimensions	24" wide x 29" deep x 24" high 610mm x 737mm x 610mm
Shipping weight	60 lb 27 kg

## Digitizer weight and dimensions: DIAGNOSTICPRO™ Advantage and DOSIMETRYPRO™ Advantage

Overall dimensions	19" wide x 23" deep x 29.25" high 483mm x 584mm x 743mm
Footprint	19" wide x 23" deep 483mm x 584mm
Weight	40 lb 18 kg

## Digitizer weight and dimensions: CADPRO™ Advantage

Overall dimensions	19" wide x 21.25" deep x 25.5" high 483mm x 540mm x 648mm
Footprint	19" wide x 21.25" deep 483mm x 540mm
Weight	40 lb 18 kg

baylandtechnologies.com  
telephone: 1-800-801-8432

# SCSI information and troubleshooting guide

---

## Introduction

VIDAR digitizer installation instructions provide basic guidance for installing SCSI hardware and software. That information enables most customers to successfully install and connect their digitizers to recommended SCSI controllers.

Some customers, however, may encounter situations in which the basic SCSI installation information is insufficient. This appendix provides additional information, and offers troubleshooting guidance for common problems.

## Digitizer and SCSI controller compatibility

VIDAR film digitizers have been validated with the Adaptec™ 2930CU SCSI adapter card. Do not use other SCSI adapter cards. Ultra-wide SCSI adapters are not compatible with VIDAR film digitizers.



Bayland

baylandtechnologies.com  
telephone: 1-800-801-8432

## SCSI cable

Use **VIDAR part number 4270 only**.

### Connecting the cable

**Note:** Attach or remove the SCSI cable carefully to avoid bending the connector pins. Insert the connector straight into the SCSI port. Inserting the connector at an angle may damage the pins. If the pins or cable are damaged, improper SCSI operation may result.

**Note:** Before connecting the SCSI cable, be certain that the PC and digitizer are OFF.

1. **Carefully** attach the SCSI connector to the digitizer's SCSI port. Apply even pressure to avoid bending SCSI connector pins. **Do not force the connectors together.**
2. Connect the other end of the cable to the SCSI port on the computer.

**WARNING:** If the SCSI connector has bent pins, it will damage the SCSI port in the digitizer. Do not attempt to straighten bent pins. Discard any SCSI cable with bent pins and replace it with a new cable.



Bayland

baylandtechnologies.com  
telephone: 1-800-801-8432

## Troubleshooting

- **Problem:** A BIOS banner does not appear for an adapter that has a BIOS chip.  
or  
A BIOS banner appears, but there is an error message (“Host Adapter Configuration Error”).

This error at system boot indicates the PCI interrupt has not been configured correctly. Do not continue with installation until this problem has been resolved.

Check these items in the system CMOS/BIOS (they will usually be found under PCI or PnP configuration):

- PCI slot should be enabled.
- Bus mastering should be enabled.
- IRQ triggering should be set to Level.
- There should be enough IRQs available for PCI/PnP.

Also, try installing the adapter in another PCI slot.

- **Problem:** Driver is installed, but Windows™ fails to run when you reboot.

There is probably a resource conflict.

- **Problem:** System locks up with memory errors or no video.

There could be a BIOS address conflict. Contact the BIOS manufacturer and update the system BIOS to the most recent version.

Bayland

baylandtechnologies.com  
telephone: 1-800-801-8432

- **Problem:** System locks up or freezes when the driver loads.
  - Check for IRQ conflicts.
  - Check the system CMOS for any PCI slot or IRQ options that enable you to reserve an IRQ for PCI/PnP.
  - Try the adapter in another PCI slot (primary or first slot preferred).

- **Problem:** You installed a PnP adapter in Windows™, and the PnP does not load the driver.

Disable the PnP on the adapter. Check adapter documentation for instructions.

- **Problem:** Digitizer is not listed in Windows™ Control Panel > Scanners and Cameras (Windows™ 2000 or Windows™ XP).
  - Update to STI drivers. See “Computers with Windows™ 2000 and Windows™ XP” in the “Installing device drivers” chapter.
  - Check all SCSI cables and connectors.
- **Problem:** Digitizer is not detected on SCSI bus.
  - Set up SCSI card. See the “Installing SCSI hardware” chapter.
  - Check all SCSI cables and connectors.

The logo for Bayland Technologies, featuring a stylized, multi-colored flower or leaf design in shades of purple, blue, and yellow, positioned above the word "Bayland" in a large, light blue, sans-serif font.

Bayland

baylandtechnologies.com  
telephone: 1-800-801-8432

- **Problem:** SCSI card driver not loading or hanging during Windows™ 2000 installation.

This applies to all Adaptec™ PCI SCSI adapters/cards running the Windows™ 2000 operating system.

**Note:** Use these troubleshooting steps in sequence. Stop when the problem is corrected and do not execute the next step!

1. Update the motherboard BIOS to make it A.C.P.I. compliant (ACPI= Advanced Configuration & Power Interface)
2. Disable P.M. and A.C.P.I. in motherboard CMOS (PM= Power Management).
3. Set the option for PnP OS to “No” in motherboard CMOS, even though Windows™ 2000 is a PnP OS.
4. Press the F6 key at Windows™ 2000 CD boot. It allows selecting another SCSI card if necessary. Unfortunately, only the four top drives are displayed, and there is no way to scroll (a Microsoft limitation).
5. Press the F6 key at Windows™ 2000 CD boot. Selecting “Standard PC” installs Windows™ 2000 without ACPI support.



Bayland

baylandtechnologies.com  
telephone: 1-800-801-8432



# Packing the film digitizer for shipment

---

**IMPORTANT:** When shipping the film digitizer, you **must** use the original packing materials, including wire ties, plastic bags, plastic wrap, foam supports and cartons. Improper packaging may allow damage to the digitizer, which will incur additional charges for repair.

## 1. Turn off the digitizer

Press “0” on the power switch.

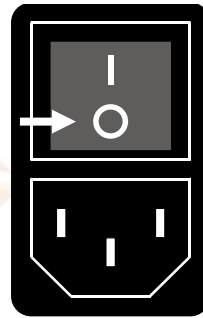

Bayland

baylandtechnologies.com  
telephone: 1-800-801-8432

## 2. Disconnect the power cord and SCSI or USB cable

- a. Disconnect the power cord from the Power Entry Module on the rear of the digitizer.
- b. Disconnect the SCSI or USB cable from the rear of the digitizer.

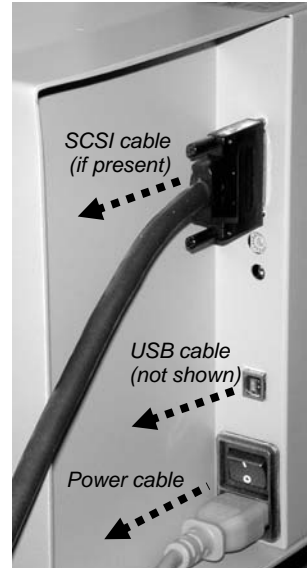

baylandtechnologies.com  
telephone: 1-800-801-8432

### 3. Remove the exit tray from the digitizer base

Lift the exit tray up to disengage it from the plastic edge just below the rollers, then pull it gently toward you.

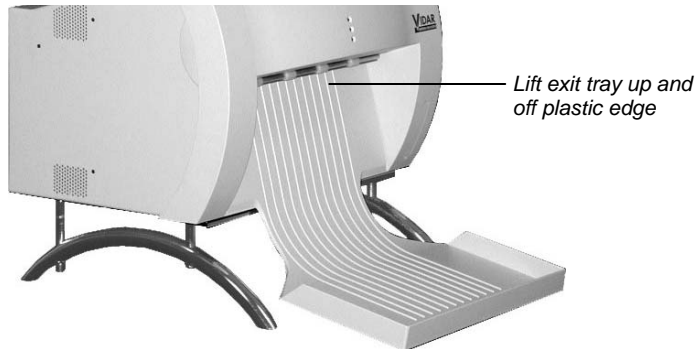

*Removing DIAGNOSTICPRO™ Advantage and DOSIMETRYPRO™ Advantage exit tray*



*Removing CADPRO™ Advantage exit tray*

Bayland

baylandtechnologies.com  
telephone: 1-800-801-8432

## 4. Remove the feeder from the digitizer base

- a. [DIAGNOSTICPRO™ Advantage and DOSIMETRYPRO™ Advantage only]  
Remove the film support bar from the top of the feeder.

**Note:** You must remove the film support bar before packing the feeder, otherwise the feeder will not fit into the foam support.

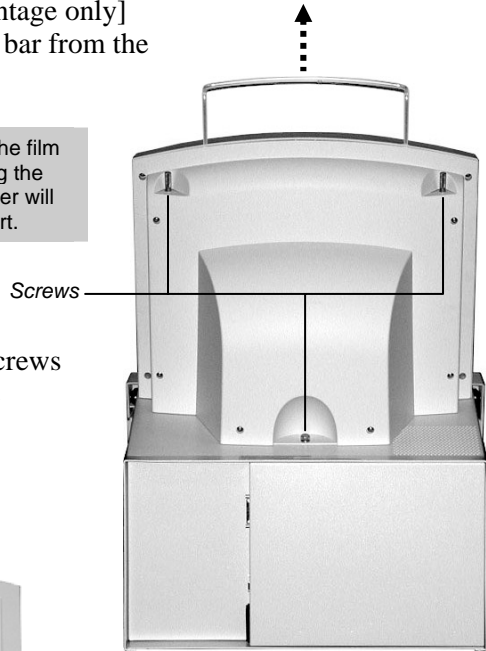

- b. Loosen the three thumbscrews securing the feeder to the digitizer base.

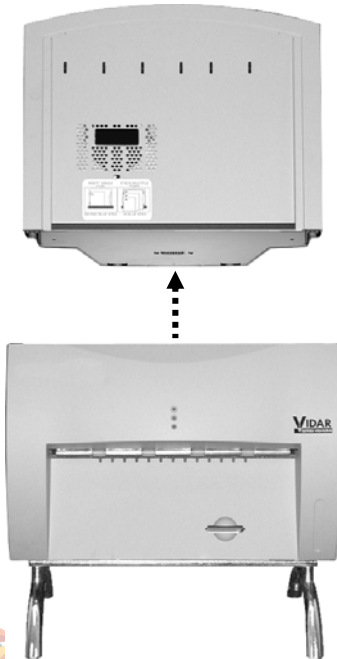

- c. Lift the feeder up and off the digitizer base.



Daylanu  
technologies

landtechnologies.com  
telephone: 1-800-801-8432

## 5. Remove the digitizer base from the stand

[DIAGNOSTICPRO™ Advantage and DOSIMETRYPRO™ Advantage only]

Loosen the thumbscrews on the bottom of the stand, then lift the digitizer base from the stand.

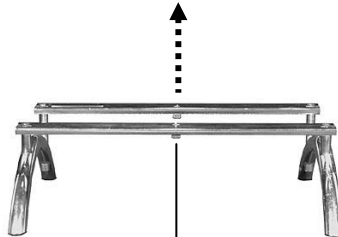
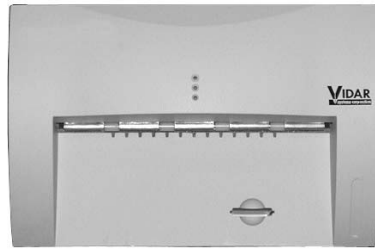

Thumbscrews (2)



Bayland

baylandtechnologies.com  
telephone: 1-800-801-8432

## 6. Prepare the feeder [CADPRO™ Advantage only]

- a. Secure the film feeder Suction Cup Arm using the foam wedge as shown below.

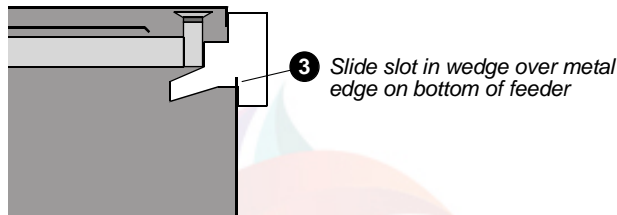
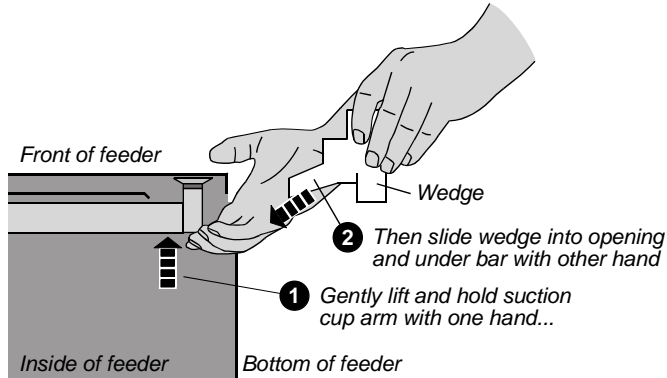

Feeder with wedge inserted should look like this:

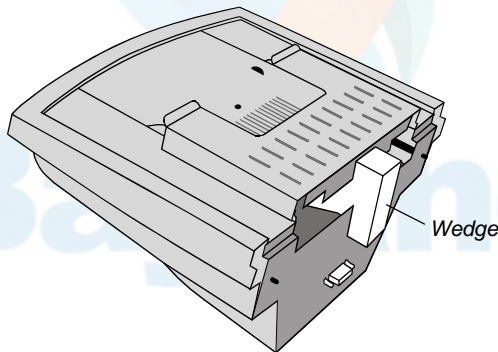

- b. Place the film feeder in a plastic bag. Seal the bag with tape.

## 7. Wrap certain items

- a. Insert the foam block in the rear of the digitizer base.

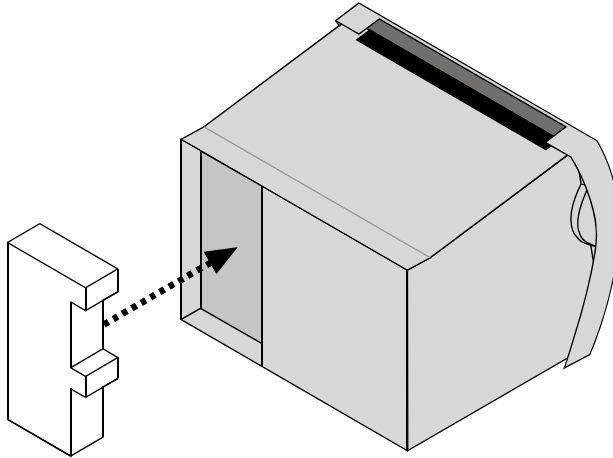

- b. Place the digitizer base in a plastic bag. Seal the bag with tape.
- c. Place the film feeder in a plastic bag. Seal the bag with tape.
- d. Place the exit tray in a plastic bag. Seal the bag with tape.
- e. Place the film support bar in a padded bag. Seal the bag with tape.

**Bayland**

baylandtechnologies.com  
telephone: 1-800-801-8432

## 8. Pack the accessory box

### DIAGNOSTICPRO™ Advantage and DOSIMETRYPRO™ Advantage only

- a. Place these items in the accessory box in the order shown here. Orient the items as shown. When the cardboard retainer is in place, the two runners on the exit tray should protrude through the two slots in the retainer.

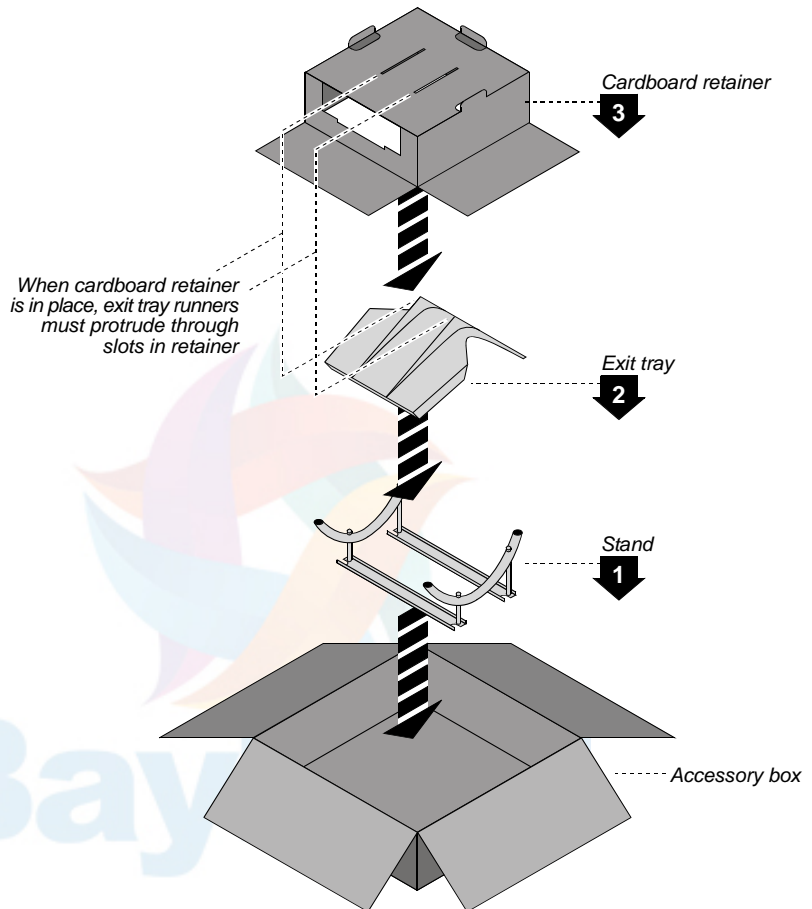

**Note:** For clarity, this illustration does not show the protective plastic bag surrounding the exit tray.

baylandtechnologies.com  
telephone: 1-800-801-8432



b. Place these items on the cardboard retainer:

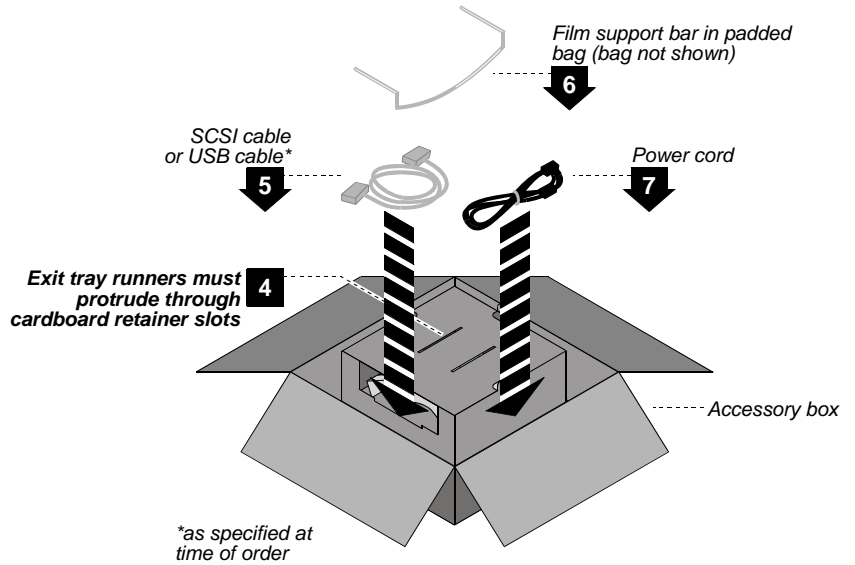

c. Close the accessory box and seal it with tape.



baylandtechnologies.com  
telephone: 1-800-801-8432

## CADPRO™ Advantage only

- a. Place these items in the accessory box in the order shown here. Orient the items as shown.

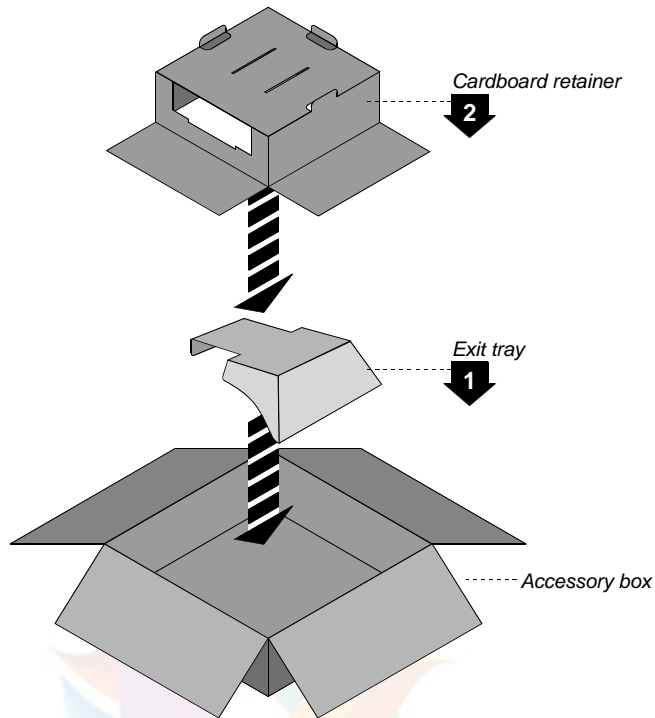

**Note:** For clarity, this illustration does not show the protective plastic bag surrounding the exit tray.

# Bayland

baylandtechnologies.com  
telephone: 1-800-801-8432

b. Place these items on the cardboard retainer flap:

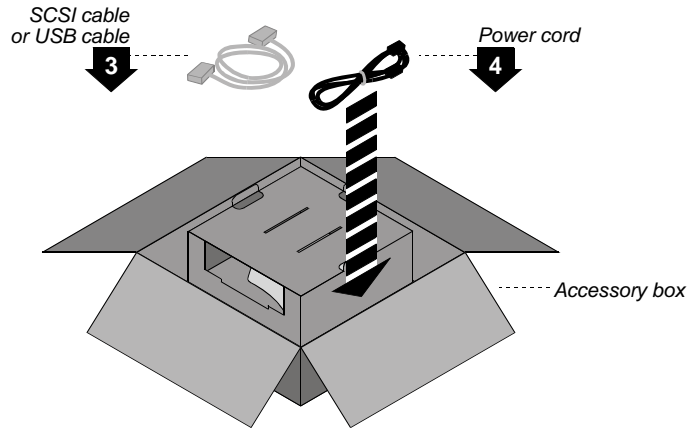

c. Close the accessory box and seal it with tape.



baylandtechnologies.com  
telephone: 1-800-801-8432

## 9. Pack the shipping carton

- a. Place the items shown in the shipping carton, as shown here. Orient the items as shown.

**Note:** For clarity, this illustration does not show the plastic bags surrounding the digitizer and feeder.

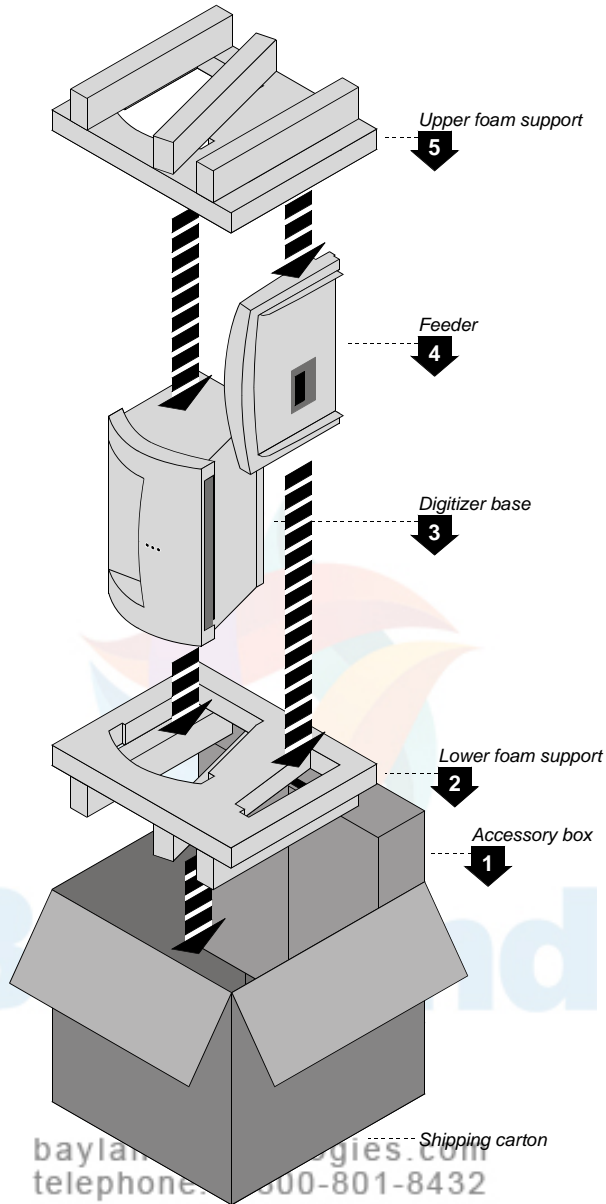

b. Close the shipping carton and seal it with tape.

**Note:** If you are shipping the digitizer to VIDAR for repair or any other reason:

1. Obtain a Returned Materials Authorization (RMA) number by sending an e-mail request to [medtech@vidar.com](mailto:medtech@vidar.com). Include the digitizer's serial number and the reason for return.
2. Write the RMA number on the box or shipping label. If the shipment does not have an RMA, processing will be delayed when it reaches VIDAR.



[baylandtechnologies.com](http://baylandtechnologies.com)  
telephone: 1-800-801-8432

# Electromagnetic guidance

**Caution: Medical electrical equipment.**

**EMC (Electro Magnetic Compatibility) must be considered before any medical electrical equipment is installed or put into service. Follow the information in the accompanying documentation when installing and operating the Digitizer.**

**Caution: Portable or mobile RF communication equipment can effect Medical Electrical equipment.**

**Caution: Using the Digitizer adjacent to or stacked with other equipment may cause interference between the equipment. Before utilizing stacked or adjacent equipment, verify proper functionality of all equipment in the actual configuration in which it will operate.**

**Caution: Connecting the Digitizer to equipment that is not rated CISPR 11 class A or class B may alter the electromagnetic characteristics.**

**Caution: In a domestic environment this product may cause radio interference in which case the user may be required to take adequate measures.**

Guidance and manufacturer's declaration - electromagnetic immunity			
Guidance and manufacturer's declaration - electromagnetic immunity			
Table 202 Table 201			
The DIAGNOSTICPRO Advantage, DOSIMETRYPRO Advantage and CADPRO Advantage Digitizers are intended for use in the electromagnetic environment specified below. The customer or end user of the Digitizer should assure that it is used in such an environment. The customer or end user should assure that they are used in such an environment.			
Immunity test	IEC 60601 test level	Compliance level	Electromagnetic environment - guidance
RF Emissions Electrostatic Discharge (ESD) CISPR IEC 61000-4-2	+ 6 kV contact Group 1 + 8 kV air	+ 6 kV contact + 8 kV air	The Digitizers use RF energy only for their internal functions. Therefore, their RF emissions are very low and are not likely to cause any interference with electronic equipment. Floors should be wood, concrete or ceramic tile. Floors are covered with synthetic material, the relative humidity should be at least 30%
RF Emissions (CISPR11) Electrical fast transient burst Harmonic Emissions IEC 61000-3-2	Class A ±2 kV for power supply lines Class A	±2 kV for power supply lines	Mains power quality should be that of a typical commercial or hospital. The Digitizers are suitable for use in all establishments other than domestic and those directly connected to the public low voltage power supply network that supplies buildings used for domestic purposes.
Voltage Fluctuations/ flicker emissions IEC 61000-3-3	Complies		

# Bayland

baylandtechnologies.com  
telephone: 1-800-801-8432

IEC 61000-4-4	$\pm 1$ kV for input/output lines	$\pm 1$ kV for input/output lines	environment.
Surge IEC 61000-4-5	$\pm 1$ kV differential mode $\pm 2$ kV common mode	$\pm 1$ kV differential mode $\pm 2$ kV common mode	Mains power quality should be that of a typical commercial or hospital environment.
Voltage dips, short interruptions and voltage variations on power supply input lines  IEC 61000-4-11	<5 % $U_T$ (>95 % dip in $U_T$ ) for 0,5 cycle  40 % $U_T$ (60 % dip in $U_T$ ) for 5 cycles  70 % $U_T$ (30 % dip in $U_T$ ) for 25 cycles  <5 % $U_T$ (>95 % dip in $U_T$ ) for 5 sec	<5 % $U_T$ (>95 % dip in $U_T$ ) for 0,5 cycle  40 % $U_T$ (60 % dip in $U_T$ ) for 5 cycles  70 % $U_T$ (30 % dip in $U_T$ ) for 25 cycles  <5 % $U_T$ (>95 % dip in $U_T$ ) for 5 sec	Mains power quality should be that of a typical commercial or hospital environment. If the user of the Digitizer requires continued operation during power mains interruptions, it is recommended that the Digitizer be powered from an uninterruptible power supply or a battery
Power frequency (50/60 Hz) magnetic field IEC 61000-4-8	3 A/m	3 A/m	Power frequency magnetic fields should be at levels characteristic of a typical location in a typical commercial or hospital environment.
NOTE: $U_T$ is the a.c. mains voltage prior to application of the test level.			



baylandtechnologies.com  
telephone: 1-800-801-8432

## Guidance and manufacturer's declaration – electromagnetic immunity

Table 204

The Digitizer is intended for use in the electromagnetic environment specified below. The customer or end user of the Digitizer should assure that it is used in such an environment.

Immunity test	IEC 60601 test level	Compliance level	Electromagnetic environment - guidance
Conducted RF IEC 61000-4-6	3 Vrms 150 kHz to 80 MHz	3 V	<p>Portable and mobile RF communication equipment should be used no closer to any part of the Digitizer, including cables, than the recommended separation distance calculated from the equation applicable to the frequency of the transmitter.</p> <p>Recommended separation distance</p> $d = 1.2\sqrt{P}$
Radiated RF IEC 61000-4-3	3 V/m 80 MHz to 2,5 GHz	3 V/m	$d = 1.2\sqrt{P}$ 80 MHz to 800 MHz $d = 2.3\sqrt{P}$ 800 MHz to 2.5 GHz
			<p>Where <math>P</math> is the maximum output power rating of the transmitter in watts (W) according to the transmitter manufacturer and <math>d</math> is the recommended separation distance in meters (m).</p> <p>Field strengths from fixed RF transmitters, as determined by an electromagnetic site survey,<sup>a</sup> should be less than the compliance level in each frequency range.<sup>b</sup></p> <p>Interference may occur in the vicinity of equipment marked with the following symbol:</p> 

Note1: At 80MHz and 800MHz, the higher frequency range applies.

Note 2: These guidelines may not be applicable in all situations. Electromagnetic propagation is affected by absorption and reflection from structures, objects and people.

<sup>a</sup> Field strengths from fixed transmitters, such as base stations for radio (cellular/cordless) telephones and land mobile radios, amateur radio, AM and FM radio broadcast and TV broadcast cannot be predicted theoretically with accuracy. To assess the electromagnetic environment due to fixed RF transmitters, an electromagnetic site survey should be considered. If the measured field strength in the location in which the Digitizer is used exceeds the applicable RF compliance level above, the Digitizer should be observed to verify normal operation. If abnormal performance is observed, additional measures may be necessary, such as reorienting or relocating the Digitizer.

<sup>b</sup> Over the frequency range 150 kHz to 80 MHz, field strengths should be less than 3 V/m.

# Bayland

baylandtechnologies.com  
telephone: 1-800-801-8432



## Recommended separation distances between portable and mobile RF communications equipment and the Digitizer

Table 206

The Digitizer is intended for use in an electromagnetic environment in which radiated RF disturbances are controlled. The customer or the user of the Digitizer can help prevent electromagnetic interference by maintaining a minimum distance between portable and mobile RF communications equipment (transmitters) and the Digitizer as recommended below, according to the maximum output power of the communications equipment.

Rated maximum output power of transmitter W	Separation distance according to frequency of transmitter, m		
	150 kHz to 80 MHz $d = 1.2\sqrt{P}$	80 MHz to 800 MHz $d = 1.2\sqrt{P}$	800 MHz to 2.5 GHz $d = 2.3\sqrt{P}$
0.01	0.12	0.12	0.23
0.1	0.37	0.37	0.74
1	1.2	1.2	2.3
10	3.7	3.7	7.4
100	12	12	23

For transmitters rated at a maximum output power not listed above, the recommended separation distance  $d$  in meters (m) can be estimated using the equation applicable to the frequency of the transmitter, where  $P$  is the maximum output power rating of the transmitter in watts (W) according to the transmitter manufacturer.

NOTE 1: At 80 MHz and 800 MHz, the separation distance for the higher frequency range applies.

NOTE 2: These guidelines may not apply in all situations. Electromagnetic propagation is affected by absorption and reflection from structures, objects and people.



# Bayland

baylandtechnologies.com  
telephone: 1-800-801-8432



## **Disposal of Waste Equipment by Users in the European Union**

This symbol on the product indicates that this product must not be disposed of as unsorted municipal waste. Instead, it is your responsibility to dispose of your waste equipment by handing it over to a designated collection point for recycling of waste electrical and electronic equipment. The separate collection and recycling of your waste equipment will help to conserve natural resources and ensure that it is recycled in a manner that protects human health and the environment. For more information about where you can dispose of your waste equipment for recycling please contact your local city office, your household waste disposal service or the shop where you purchased the product.

Note on WEEE, 6799D237



# Bayland

baylandtechnologies.com  
telephone: 1-800-801-8432



baylandtechnologies.com  
telephone: 1-800-801-8432



**365 Herndon Parkway  
Herndon, VA 20170 USA  
Phone: 1-703-471-7070  
Main fax: 1-703-471-1165  
Web: [www.filmdigitizer.com](http://www.filmdigitizer.com)**

**Technical Support:  
Phone: 1-703-471-7070  
1-800-471-7226  
Fax: 1-703-471-7665  
[medtech@vidar.com](mailto:medtech@vidar.com)**

**Bayland**

**baylandtechnologies.com  
telephone: 1-800-801-8432**

---