

Echo Fix

CHORUS ECHO EF-X3R

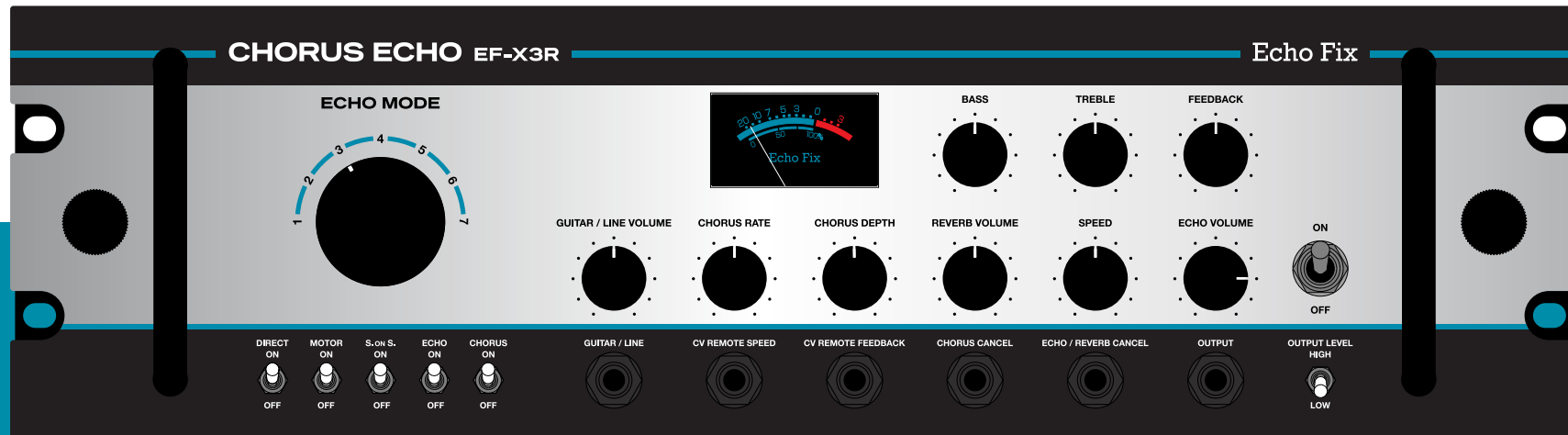

USER MANUAL

THANK YOU FOR CHOOSING THE EF-X3R CHORUS ECHO

Congratulations on your purchase of the EF-X3R Chorus Echo!

If you have not owned a tape echo unit before, it is strongly recommended that you review this document prior to use.

TABLE OF CONTENTS

1. Start here
2. Installation
3. Understanding the EF-X3R - Front Panel
4. Understanding the EF-X3R - Rear Panel
5. Remote Inputs
6. Spring Reverb & Analog BBD Chorus
7. Upkeep and troubleshooting

1 START HERE

For nearly 15 years, we've been keeping tape echos alive. Now that we make our own, our standards are higher than ever. Built by the same team to the highest quality, this new machine includes many of our most requested features and builds on the momentum and trust gained after 3 years of making the EF-X2. Rest assured that your machine will be the most capable, reliable tape echo on the market, supported by a team with some of the best customer service in the industry.

We have designed this manual to assist in getting the best possible result from your EF-X3R. Please note the following and keep them in mind as you get to know your unit:

- The EF-X3R is an electromechanical, analog tape echo device. The echo is produced by a tape loop engaging with multiple read and write heads,

therefore some inherent tape hiss and minor noise artefacts will always be present. However, you can radically improve your signal to noise ratio by ensuring your input signal is loud enough to reach '0' on the VU Meter and cause your peak light to flash red. This will give you the best echo sound quality.

- When it comes to maintaining your unit, please use only genuine Echo Fix parts and tape loops. Using anything other than Echo Fix tape loops will void your warranty and could damage your EF-X3R.
- We are excited to offer CV control with the unit. Please do not use voltages outside of the 0-5v range. Doing so will void your warranty and may cause damage to the unit.

2 INSTALLATION

Mount your EF-X3R using 4 x screws appropriate to your your 19" rack. Adjust and finalise the position of your EF-X3R between any other equipment before tightening screws.

Please note: Screw head diameter must be smaller than 12mm.

CAUTION! It is recommended that the installation of your EF-X3R be performed by two people, with one person supporting the unit in place and the second person installing the appropriate screws. To avoid damage to any of your equipment, lay down soft fabric to protect delicate surfaces.

CAUTION! To avoid tipping, always ensure your rack is secured before opening the drawer of your EF-X3R.

DRAWER REMOVAL - To remove the drawer section of the EF-X3R, pull the drawer out until it is fully extended and press tabs on runners to release the drawer section (Left Side - press down; Right Side - lift up).

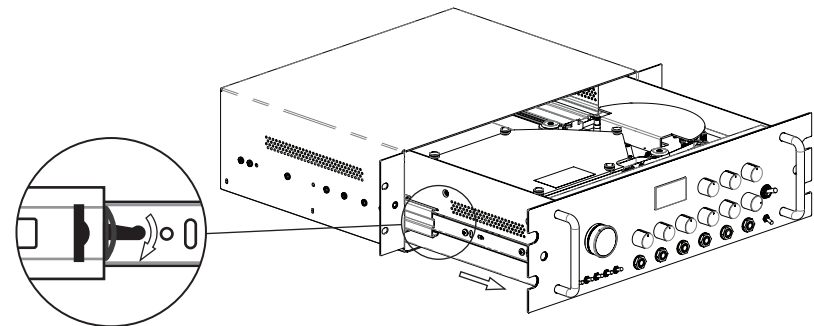
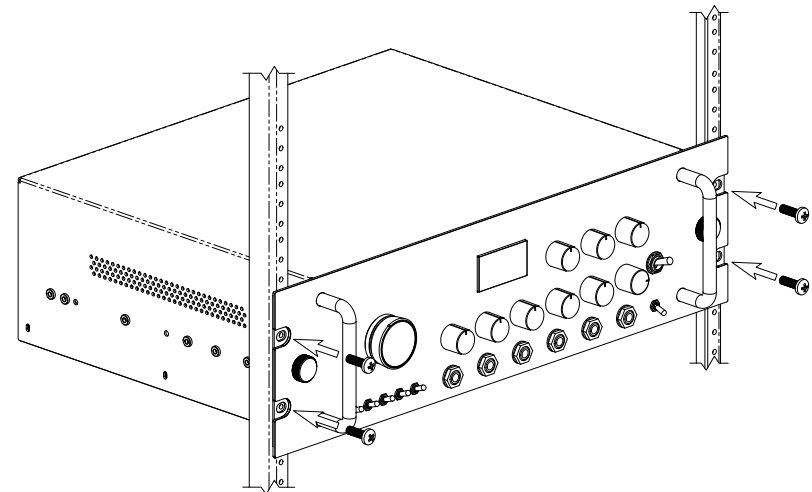

3 UNDERSTANDING THE EF-X3R FRONT PANEL

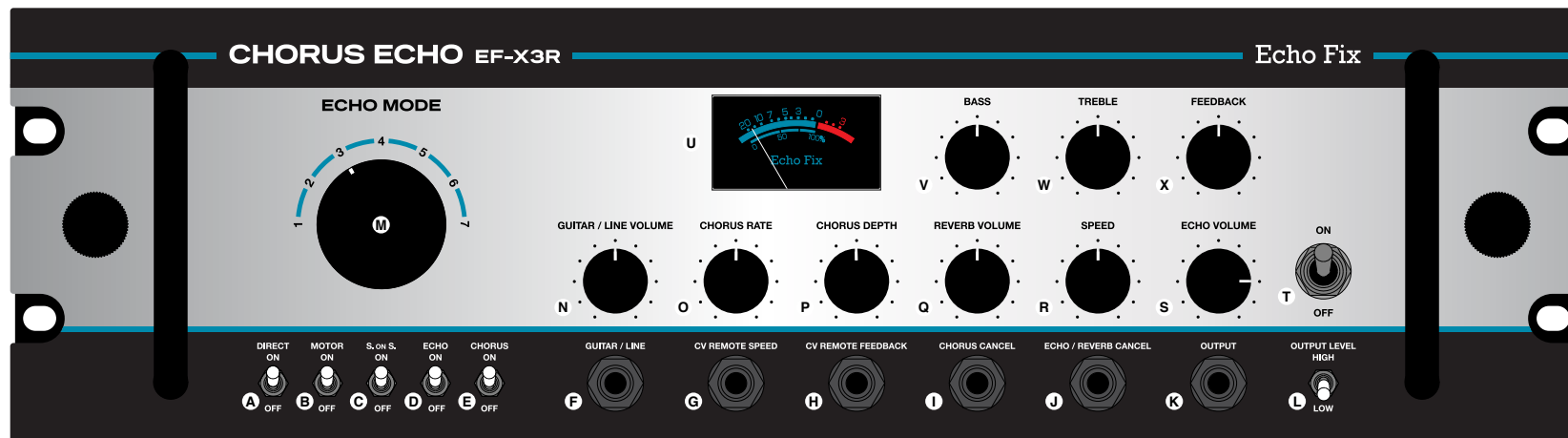

A. Direct ON/OFF Switch - Switches the direct signal ON or OFF. For traditional echo operation (wet + dry signal), set to “ON”. For wet-only, set to “OFF”.

B. Motor ON/OFF Switch - Allows you to turn the tape drive motor ON or OFF. This is useful for achieving slow down/tape stop effects or increasing tape life when using the EF-X3R as a preamp or reverb/chorus effect only.

C. Sound On Sound ON/OFF Switch - Activates the fourth playback head, positioned to achieve the longest possible delay time. The S. on S. head functions independently of the Echo ON/OFF switch.

D. Echo ON/OFF Switch - Disables playback heads 1, 2 and 3. Also turning off switch (C) allows you to use the unit as a preamp or reverb/chorus effect only. We recommend turning “Echo Volume” (S) all the way down when using the unit in this way.

E. Chorus ON/OFF Switch - Activates the chorus effect.

F. Guitar / Line - A dedicated instrument-level input with a vintage FET EP style preamp circuit (1M Ω input impedance). Input gain is controlled by (N). Front input controls do not affect rear balanced XLR input.

G. CV Remote Speed - Allows for control of the unit "speed" function using control voltages, including any TRS expression pedal (100KΩ impedance recommended). Connecting a CV source to this input will disable the "Speed" control (R).

H. CV Remote Feedback - Allows for control of the unit "feedback" function using control voltages, including an expression pedal (100KΩ impedance recommended). Connecting a CV source to this input will disable the "Feedback" control (X).

I. Chorus Cancel - Allows for bypassing of unit functions with an external footswitch. Connect a one-button TS footswitch to bypass the chorus. It is also possible to use a two-button TRS footswitch (latching type) however the ring switch will not have any effect.

J. Echo / Reverb Cancel - Allows for bypassing of unit functions with an external footswitch. Connect a one-button TS footswitch to bypass the echo only, or a two-button TRS footswitch (latching type) for bypass of the echo (tip) and reverb (ring).

K. Output - Connect to an amplifier, audio interface or additional effects processors.

L. Output Level - Sets the output level of the front output Jack (K). Note this does not set the output level of any of the rear outputs, these are fixed at high output.

M. Echo Mode - 7-position selection of the unit's playback heads. Please consult the following table for a guide to these settings:

Mode 1 - Head 1 (short) [56 - 221ms]
Mode 2 - Head 2 (medium) [121 - 477 ms]
Mode 3 - Head 3 (long) [187 - 800 ms]
Mode 4 - Head 1 + 2 (short + medium)
Mode 5 - Head 2 + 3 (medium + long)
Mode 6 - Head 1 + 3 (short + long)
Mode 7 - Head 1 + 2 + 3 (short + medium + long)

The Sound On Sound playback head can be engaged over all the above settings.

N. Guitar / Line Volume - Adjusts the gain for input (F).

O. Chorus Rate - Sets the rate of the chorus.

P. Chorus Depth - Sets the depth of the chorus by changing the amount of pitch modulation in the affected signal.

Q. Reverb Volume - Controls the volume of the spring reverb.

R. Speed - Adjusts the echo rate, corresponding to the heads selected with control (M). Turn counterclockwise for longer echo times, or clockwise for shorter.

Please note: This is controlling the physical motion of a motor and echo times will ramp up or down gradually when adjusted, with the pitch of any repeated sound being raised or lowered accordingly.

S. Echo Volume - Adjusts the volume of the echoes mixed into the overall output signal. Turned all the way to maximum, the echo volume is slightly louder than the dry signal. Please note: This does not affect the individual head outputs at the rear of the unit.

T. On / Off - Supplies power to the unit.

U. VU Meter - Indicates the input signal volume. The loudest peak signal should go "into the red" for optimal signal to noise ratio.

V. Bass - Cuts or boosts the bass frequencies of the overall output. 12 o'clock is "flat".

W. Treble - Cuts or boosts the treble frequencies of the overall output. 12 o'clock is "flat".

X. Feedback - Adjusts the amount of regenerated signal. Please note: Setting this control past 12 o'clock will likely result in self-oscillation. Additionally, using multi-head echo modes at higher feedback settings will increase the likelihood of self-oscillation.

4 UNDERSTANDING THE EF-X3R REAR PANEL

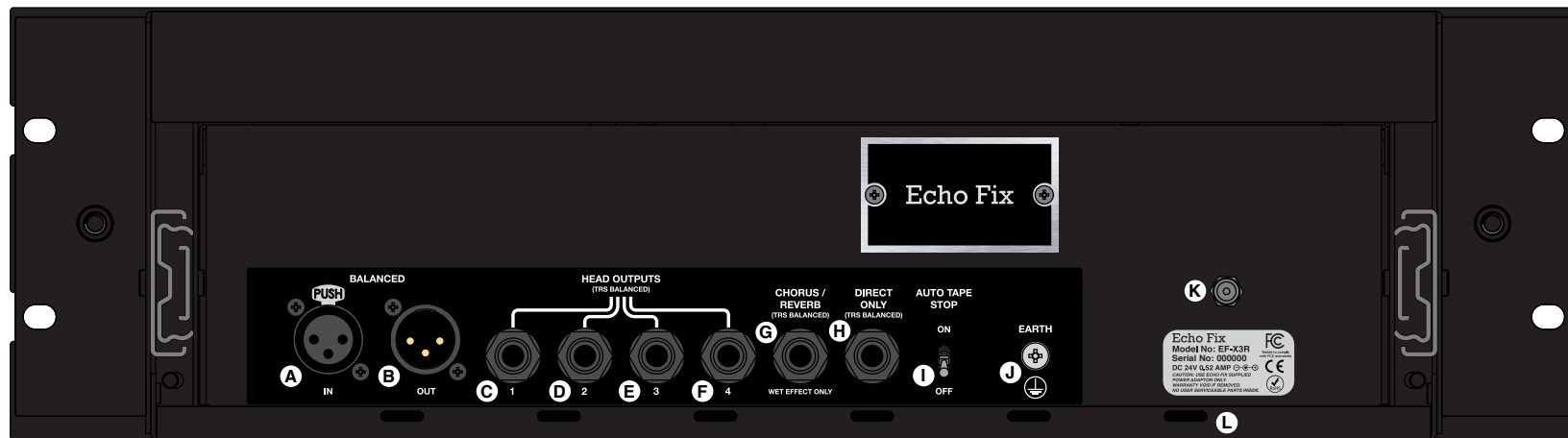

A. Balanced XLR Input - Line level input. This input can be used in addition to the input on the front. The Guitar / Line Volume knob does not affect this level.

B. Balanced XLR Output - Line level output.

C - F. Individual Head Outputs - 4 TRS balanced head outputs provide access to the signal from each of the 4 playback heads. These can be mixed and panned with a mixing desk or DAW to create a variety of echo effects.

G. Chorus / Reverb Output - Provides access to the wet effect only. In the case of the Chorus effect, wet-only results in a vibrato effect.

H. Direct Only - Provides access to a duplicate direct signal after the EF-X3R preamp.

I. Auto Tape Stop - If set to ON, the motor and roller arm will disengage after 4-5mins of not receiving signal. This increases tape life and reduces wear on the motor and tape heads. You can disable this feature by switching it to OFF.

J. Earth Point

K. DC Jack - Use Echo Fix provided power supply.

L. Cable Management Loops - Connect cable management straps (not included) to organise your cables.

5 REMOTE INPUTS

We have designed the EF-X3R to accommodate CV or expression pedal control of the tape speed and feedback functions. The control voltage range is 0 - 5v for CV control. The expression pedal needs to be a TRS output and is recommended to be 100KΩ impedance.

The echo, reverb and chorus effects can be disabled via TRS latching footswitches. The Chorus cancel has its own control input. The Echo and Reverb cancel can be operated with a dual footswitch.



6.35MM TRS CABLE

SPEED CONTROL



OR



CV OUT (0-5v)

TIP	CV Control (to EF-X3R)
RING	+5V Supply (from EF-X3R)
SLEEVE	Ground

FEEDBACK CONTROL

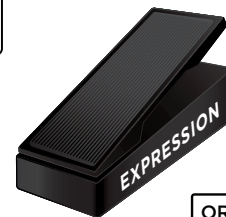

OR



CV OUT (0-5v)

1 CHANNEL FOOTSWITCH (TRS LATCHING)

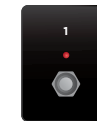

TIP	Chorus Mute
RING	N/A
SLEEVE	Ground

2 CHANNEL FOOTSWITCH (TRS LATCHING)



TIP	Echo Mute
RING	Reverb Mute
SLEEVE	Ground

6 SPRING REVERB & ANALOG BBD CHORUS

The EF-X3R has a real spring reverb and fully analog BBD chorus. They can be used in combination or on their own by adjusting (E), (O), (P) and (Q).

Blend - With chorus switch (E) in the ON position, you can adjust the amount of spring reverb in the mix by increasing (clockwise) or decreasing (counterclockwise) knob (Q).

Chorus Only - With reverb volume (Q) turned fully down (counterclockwise), only the chorus will be heard. By adjusting Rate (O) and Depth (P), various chorus settings can be achieved. Switch (E) must be in the ON position for chorus to be heard.

Vibrato - With chorus switch (E) ON, and direct switch (A) OFF, the effect heard is vibrato. The rate and depth of the vibrato are controlled by chorus controls (O) and (P).

Reverb Only - For spring reverb only, set chorus switch (E) to the OFF position. Adjust reverb volume (Q) to set the amount of spring reverb in the mix.

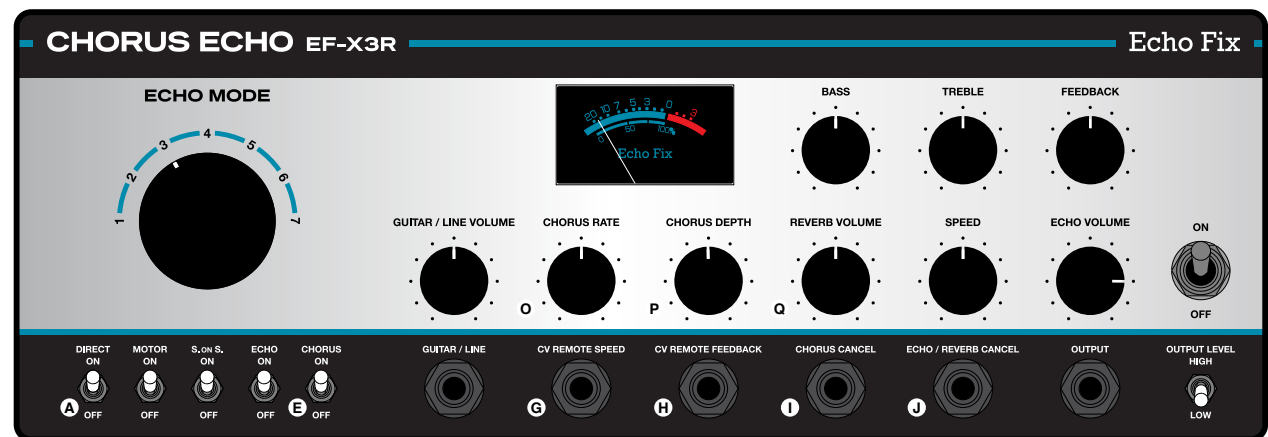

7 UPKEEP AND TROUBLESHOOTING

If you have questions or concerns, you are welcome to contact us at any time, and we'll do whatever we can to help: support@echofix.com

Your EF-X3R has been designed to last - whether in a studio environment or regularly used in a live environment, we've done everything we possibly can to ensure that your unit will be up to the task. On your end, however, there are a few simple measures you can take to ensure reliable and consistent performance.

- Tape echoes rely on the use of tape and parts that are designed for the task. We have been fitting premium parts and tape to other units for years - it hopefully goes without saying, but only use genuine Echo Fix parts for the upkeep of your unit. The fitting of inferior tape or parts will void your warranty, will adversely affect performance, and will likely damage the unit.
- Regularly clean the heads on your unit with isopropyl alcohol and cotton tips (cotton tips supplied). Please refer to our "how-to" guide on YouTube if you aren't sure how to do this.
- If you are not getting expected results from the unit, please ensure that front panel switches (A), (B), (C) and (D) are positioned as follows: Direct ON, Motor ON, S on

S OFF, Echo ON. This may seem very simple, but it's surprisingly easy to miss - even for those of us who've designed the unit. Similarly, make sure that the Guitar / Line volume control (N) is set to 12 o'clock, the Echo Volume (S) is turned up, and the Feedback Control (X) is set around 11 o'clock.

- Your unit ships with a universal-voltage switch-mode power supply. This is safe to connect to any worldwide mains voltage supply, using the correct IEC-C7 ("Figure 8") cable for your region. If your power supply is damaged or lost, replacement power supplies are available at www.echofix.com.
- If you experience excessive wow and flutter (pitch instability), this usually indicates it is time to replace the tape loop in your EF-X3R. A tape loop can last anywhere from 50 - 300 hours, depending on humidity and other atmospheric conditions. We have discounted tape loops available at www.echofix.com for EF-X3R owners.
- Your EF-X3R is covered by a limited warranty which covers manufacturing defects for the first 2 years after purchase. This warranty does not cover general wear or consumables (including tape, felt, rollers and bearings). Any damage caused by the use of non-Echo Fix branded parts (including tape and power supply) will void your warranty.

Echo Fix

CHORUS ECHO
EF-X3R

USER MANUAL

web www.echofix.com

email support@echofix.com