

### ELECTRICAL PROPERTIES

Critical Impulse Flashover Voltage		
Positive	kV	105
Impulse Withstand Voltage	kV	95
Wet p.f. Withstand Voltage	kV	30

### PHYSICAL PROPERTIES

Nominal Creepage Distance	In.	14
Net Weight	lb.	7.9
Color		Light Grey

### MECHANICAL PROPERTIES

Cantilever Strength, Upright	lb.	1200
Cantilever Strength, Underhung	lb.	1200
Torsion Strength	in. - lb.	5000
Tension Strength	lb.	5000
Reference Standard		ANSI C29.9

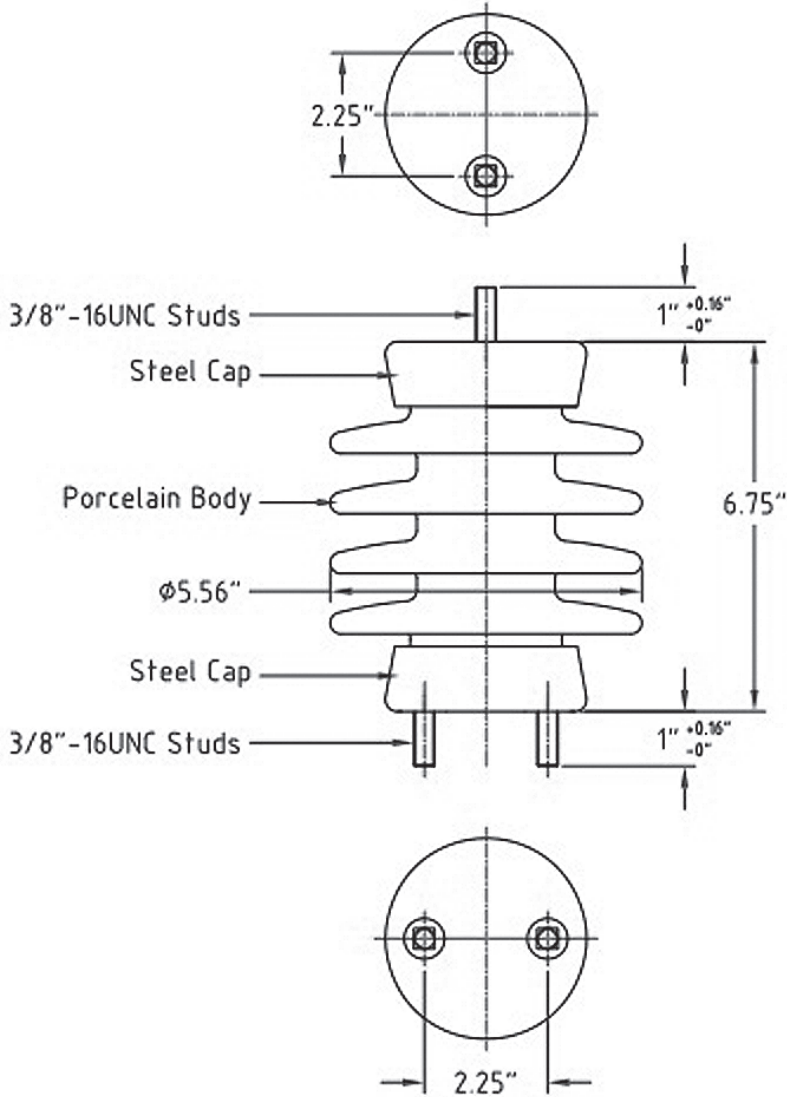

### NOTES:

1. All ferrous parts Hot Dip Galvanized.
2. Exposed cement surface coated with silicone.



**Meister** International, LLC

P.O.Box 338 Ross, Ohio 45061 USA

Tel: 513-923-2712 • Fax: 513-923-1978 • Email: sales@meisterintl.com

www.meisterintl.com

**PART NO. 6038AX**  
**PORCELAIN SWITCH POST INSULATOR**  
**15kV, 95kV BIL**