

8 7 6 5 4 3 2 1

# ELECTRO-MOTIVE DIESEL

## EMD ENGINE LIFTER

**WARNING!**  
DO NOT EXCEED RATED CAPACITY  
INSPECT BEFORE EVERY USE. REPORT ANY  
OBSERVED DAMAGE AND REMOVE LIFTER  
FROM SERVICE. IMPROPER OPERATION  
MAY RESULT IN SERIOUS INJURY.

WLL/RATED LOAD: 80,000LBS

D  
C  
B  
A

D  
C  
B  
A

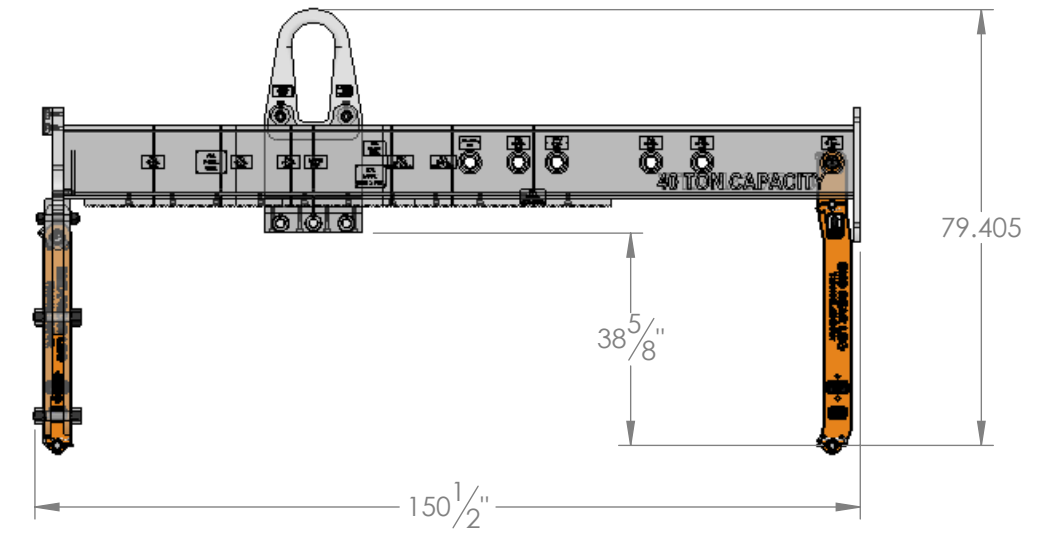
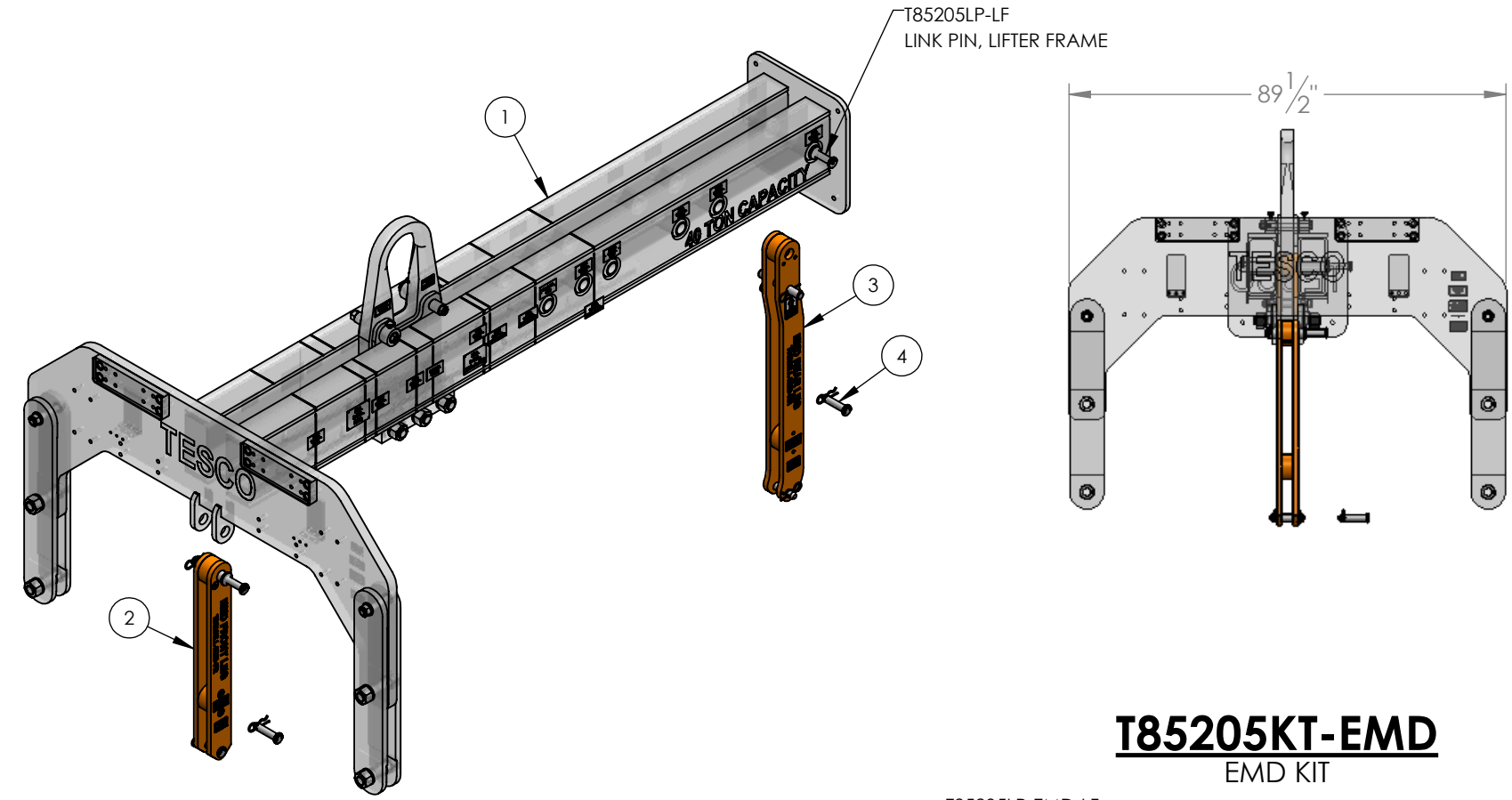

### T85205KT-EMD

#### EMD KIT

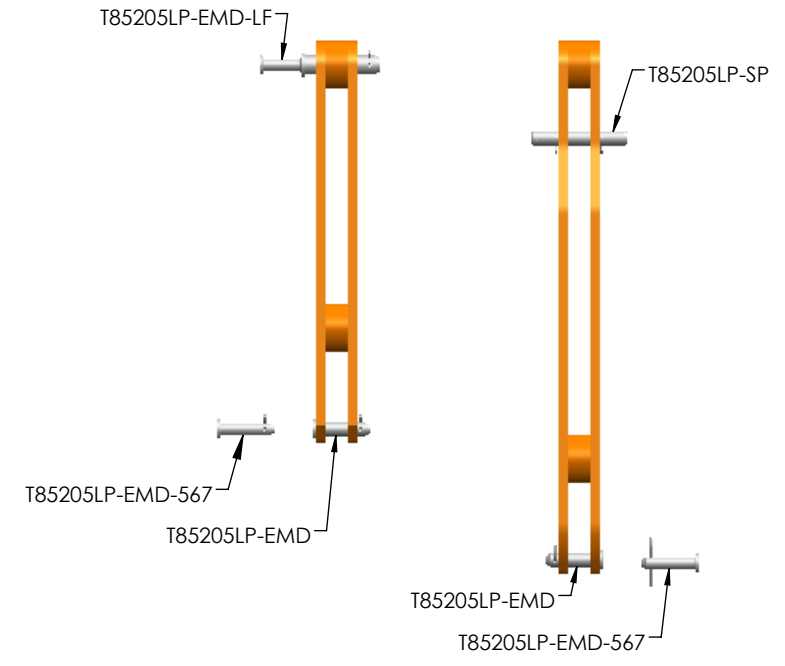

ITEM NO.	PART NUMBER	DESCRIPTION	QTY.
1	T85205	ENGINE LIFTER ASM F/EMD/FDL/GEVO/TIER 4	1
2	T85205LL-EMD-FR	EMD FRONT LIFTER LEG	1
3	T85205LL-EMD-RR	EMD REAR LIFTER LEG ASM	1
4	T85205LP-EMD-567	EMD 567 LINK PIN ASM	2

UNLESS OTHERWISE SPECIFIED:  
DIMENSIONS ARE IN INCHES  
TOLERANCES:  
FRACTIONAL: ± 1/64  
ANGULAR: MACH ± .5° BEND ± 1°  
ONE DECIMAL: .X = +0.1  
TWO PLACE DECIMAL: .XX = ±0.01  
THREE PLACE DECIMAL: .XXX = ±0.005  
INTERPRET GEOMETRIC TOLERANCING PER:  
ASME Y14.5-2009

COMPANY NAME  
**TRANSPORTATION EQUIPMENT SUPPLY COMPANY**  
8106 HAWTHORNE DRIVE  
ERIE, PA 16509  
(814) 866-1952

**TESCO**

TOOL NAME  
**EMD ENGINE LIFTER**

DWN BY CDS	DATE 1/20/2016	DWG. NO. EMD ENGINE LIFTER	REV
SIZE: B	SCALE: 1:35	WT: 5080.48 lb	SHEET 1 OF 1

**PROPRIETARY:**  
THE INFORMATION CONTAINED IN THIS  
DRAWING IS THE SOLE PROPERTY OF  
TESCO. ANY REPRODUCTION IN PART  
OR AS A WHOLE WITHOUT THE WRITTEN  
PERMISSION OF TESCO IS PROHIBITED.

8 7 6 5 4 3 2 1

# GE LOCOMOTIVE FDL ENGINE LIFTER

**WARNING!**  
DO NOT EXCEED RATED CAPACITY  
INSPECT BEFORE EVERY USE. REPORT ANY  
OBSERVED DAMAGE AND REMOVE LIFTER  
FROM SERVICE. IMPROPER OPERATION  
MAY RESULT IN SERIOUS INJURY.

WLL/RATED LOAD: 80,000LBS

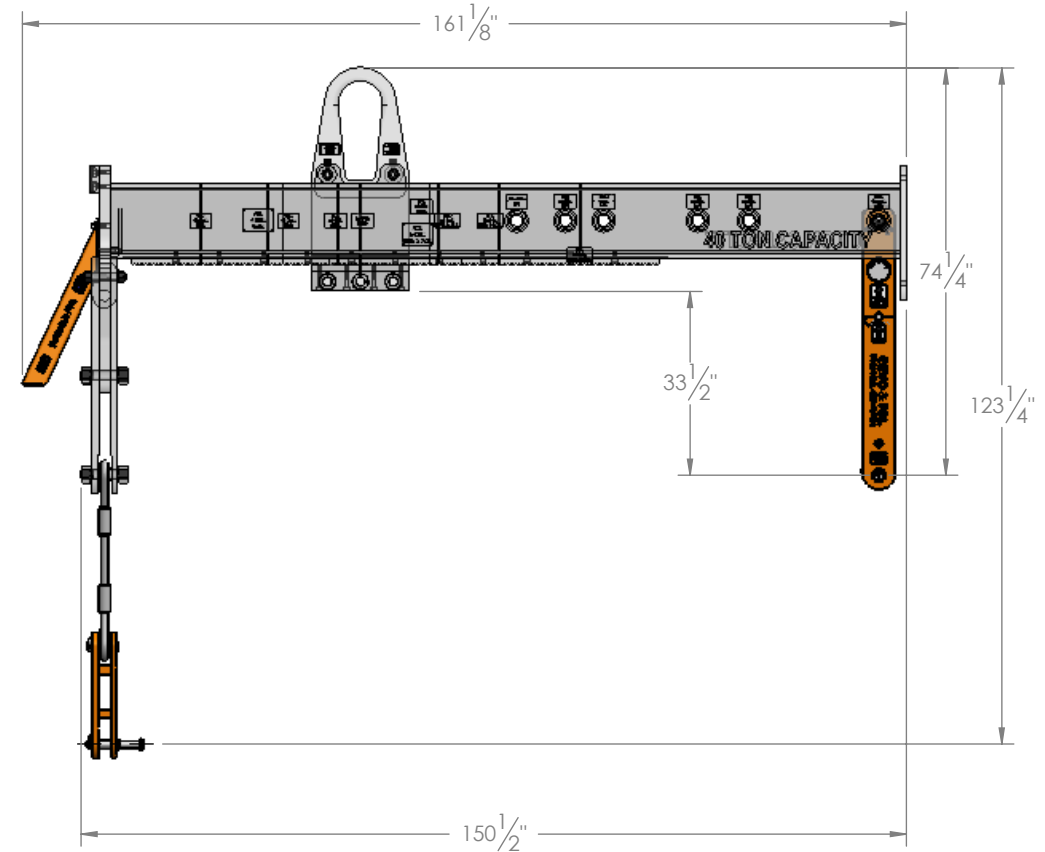
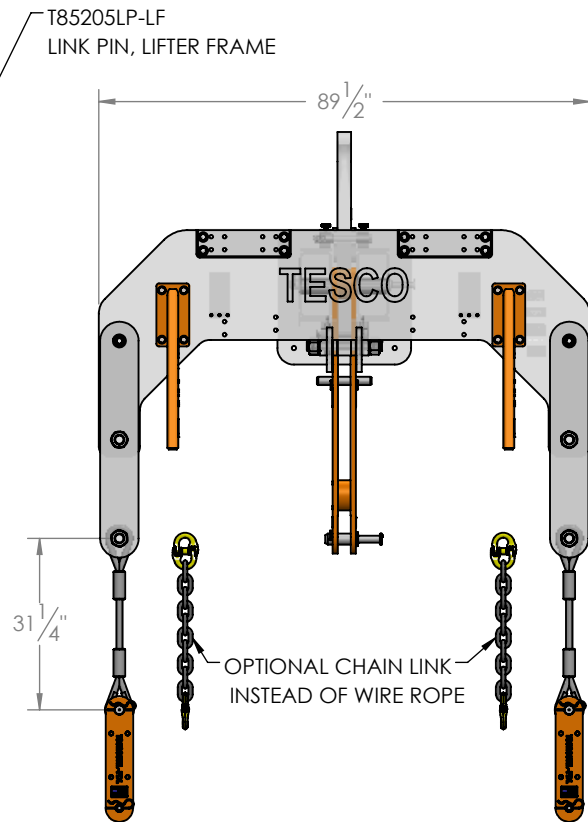
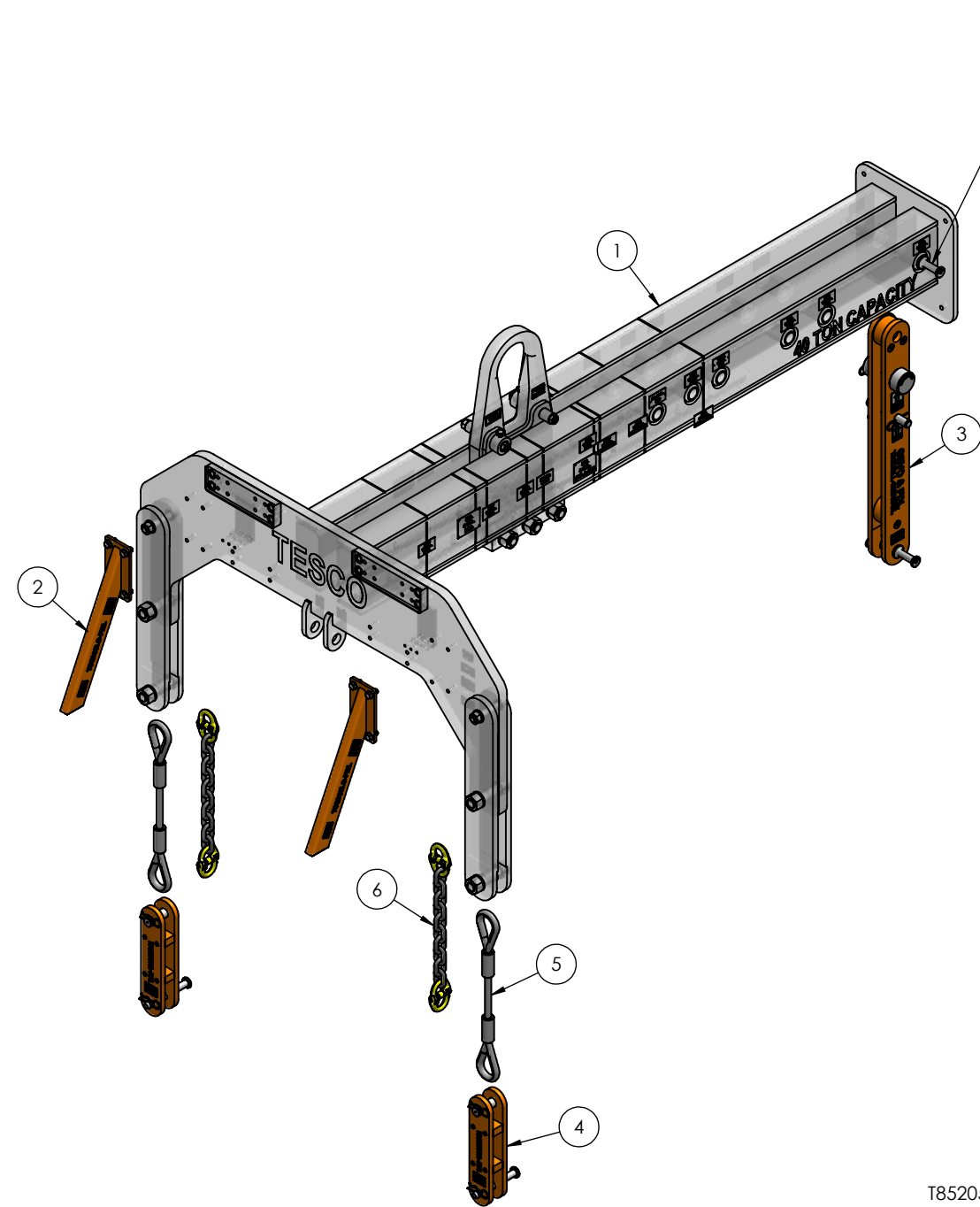

## T85205KT-FDL FDL KIT

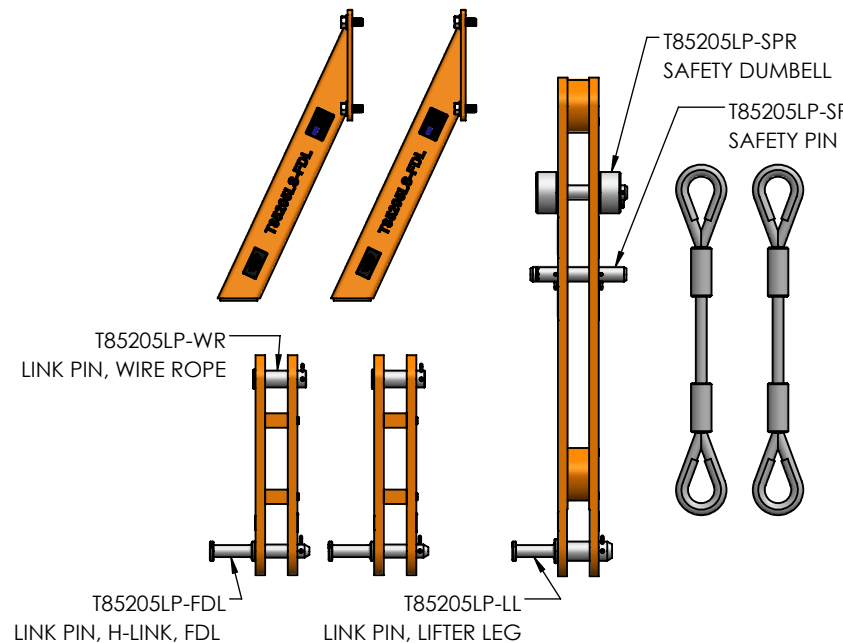

ITEM NO.	PART NUMBER	DESCRIPTION	QTY.
1	T85205	ENGINE LIFTER ASM F/EMD/FDL/GEVO/TIER 4	1
2	T85205LS-FDL	FDL LIFTER SUPPORT LEG ASM	2
3	T85205LL-GEVDFDL	LIFTER LEG F/GEVO & FDL	1
4	T85205HL-FDL	H-LINK ASM F/FDL	2
5	LC1320	1 1/8" X 34" Cable Assembly	2
6	T85205LC	ENGINE LIFTER CHAIN LINK	2

UNLESS OTHERWISE SPECIFIED:  
DIMENSIONS ARE IN INCHES  
TOLERANCES:  
FRACTIONAL: ± 1/64  
ANGULAR: MACH ± .5° BEND ± 1°  
ONE DECIMAL: .X = +0.1  
TWO PLACE DECIMAL: .XX = ±0.01  
THREE PLACE DECIMAL: .XXX = ±0.005  
INTERPRET GEOMETRIC TOLERANCING PER:  
ASME Y14.5-2009

COMPANY NAME  
TRANSPORTATION EQUIPMENT SUPPLY COMPANY  
8106 HAWTHORNE DRIVE  
ERIE, PA 16509  
(814) 866-1952

**TESCO**

TOOL NAME  
GE FDL ENGINE LIFTER

DWN BY CDS	DATE 1/20/2016	DWG. NO. FDL ENGINE LIFTER	REV
SIZE: B	SCALE: 1:35	WT: 5243.16 lb	SHEET 1 OF 1

**PROPRIETARY:**  
THE INFORMATION CONTAINED IN THIS  
DRAWING IS THE SOLE PROPERTY OF  
TESCO. ANY REPRODUCTION IN PART  
OR AS A WHOLE WITHOUT THE WRITTEN  
PERMISSION OF TESCO IS PROHIBITED.

**!WARNING!**  
DO NOT EXCEED RATED CAPACITY  
INSPECT BEFORE EVERY USE. REPORT ANY  
OBSERVED DAMAGE AND REMOVE LIFTER  
FROM SERVICE. IMPROPER OPERATION  
MAY RESULT IN SERIOUS INJURY.

**WLL/RATED LOAD: 80,000LBS**

# GE EVOLUTION LOCOMOTIVE

## GEVO ENGINE LIFTER MUFFLER REMOVED

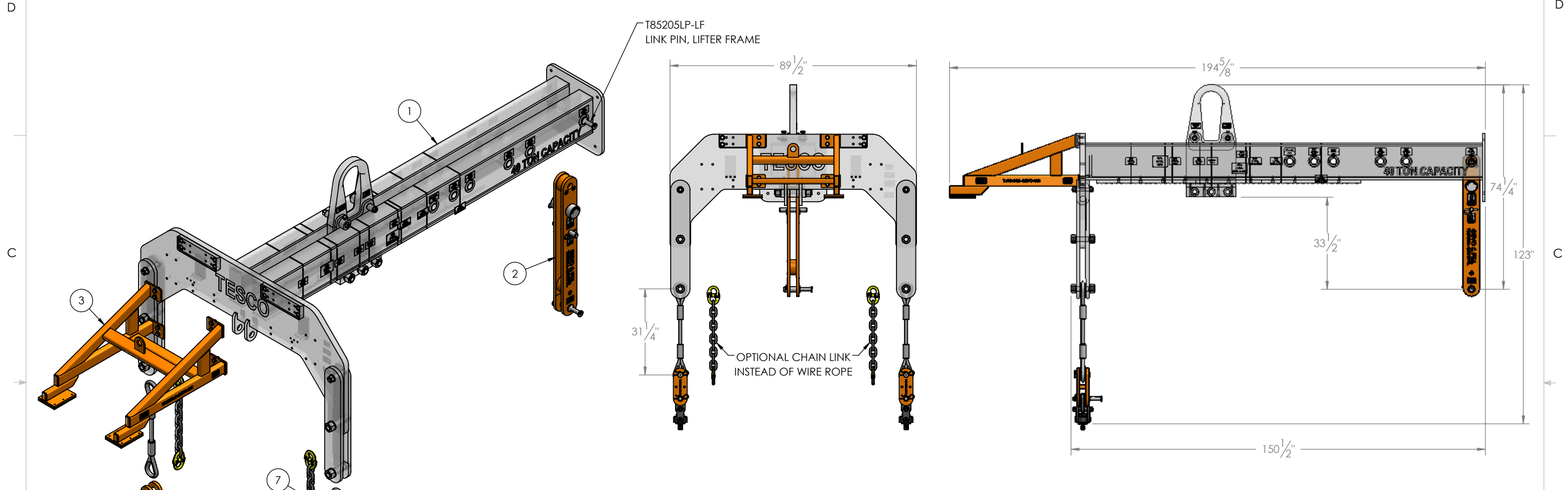

### T85205KT-GEVO-MR

#### TIER 4 MUFFLER REMOVED KIT

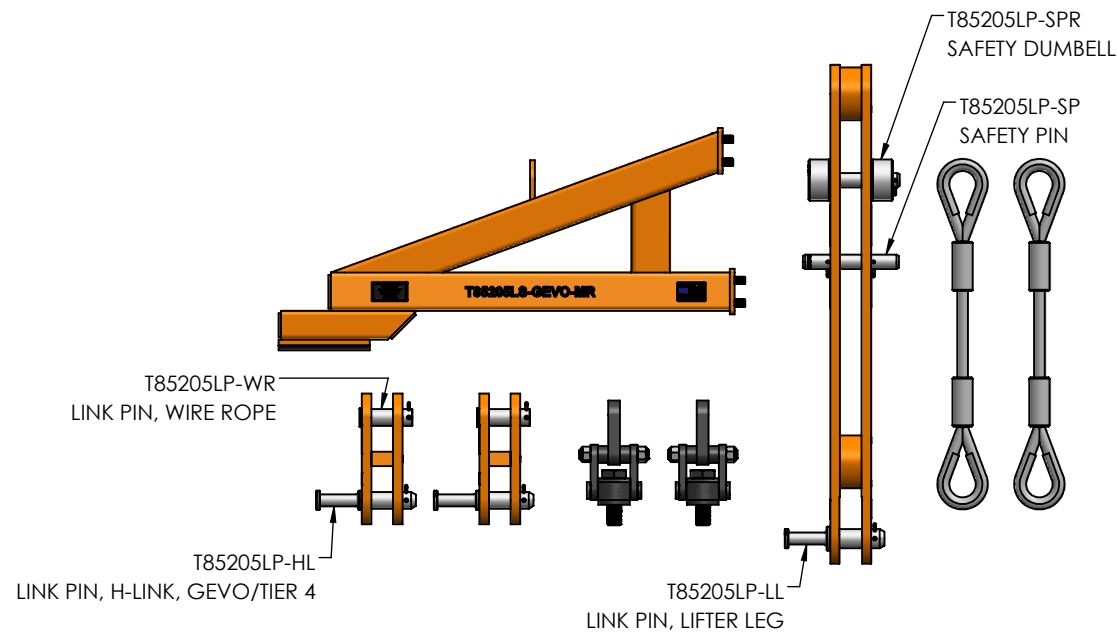

ITEM NO.	PART NUMBER	DESCRIPTION	QTY.
1	T85205	ENGINE LIFTER ASM F/EMD/FDL/GEVO/TIER 4	1
2	T85205LL-GEVOFDL	LIFTER LEG F/GEVO & FDL	1
3	T85205LS-GEVO-MR	GEVO LIFTER SUPPORT MUFFLER REMOVED ASM	1
4	T85205HL-GEVO	GEVO H-LINK	2
5	T85205SHR-GEVO	SWIVEL HOIST GEVO, M36	2
6	LC1320	1 1/8" X 34" Cable Assembly	2
7	T85205LC	ENGINE LIFTER CHAIN LINK	2

UNLESS OTHERWISE SPECIFIED:  
DIMENSIONS ARE IN INCHES  
TOLERANCES:  
FRACTIONAL: ± 1/64  
ANGULAR: MACH ± .5° BEND ± 1°  
ONE DECIMAL: .X = +0.1  
TWO PLACE DECIMAL: .XX = ±0.01  
THREE PLACE DECIMAL: .XXX = ±0.005  
INTERPRET GEOMETRIC TOLERANCING PER:  
ASME Y14.5-2009

COMPANY NAME  
**TRANSPORTATION EQUIPMENT SUPPLY COMPANY**  
8106 HAWTHORNE DRIVE  
ERIE, PA 16509  
(814) 866-1952

**TESCO**

TOOL NAME  
**GEVO ENGINE LIFTER MUFFLER REMOVED**

DWN BY CDS	DATE 1/20/2016	DWG. NO. GEVO-MR ENGINE LIFTER	REV
---------------	-------------------	-----------------------------------	-----

SIZE: B SCALE: 1:35 WT: 5438.63 lb SHEET 1 OF 1

**PROPRIETARY:**  
THE INFORMATION CONTAINED IN THIS  
DRAWING IS THE SOLE PROPERTY OF  
TESCO. ANY REPRODUCTION IN PART  
OR AS A WHOLE WITHOUT THE WRITTEN  
PERMISSION OF TESCO IS PROHIBITED.

8 7 6 5 4 3 2 1

# GE EVOLUTION LOCOMOTIVE

## GEVO ENGINE LIFTER MUFFLER ATTACHED

**!WARNING!**  
DO NOT EXCEED RATED CAPACITY  
INSPECT BEFORE EVERY USE. REPORT ANY  
OBSERVED DAMAGE AND REMOVE LIFTER  
FROM SERVICE. IMPROPER OPERATION  
MAY RESULT IN SERIOUS INJURY.

WLL/RATED LOAD: 80,000LBS

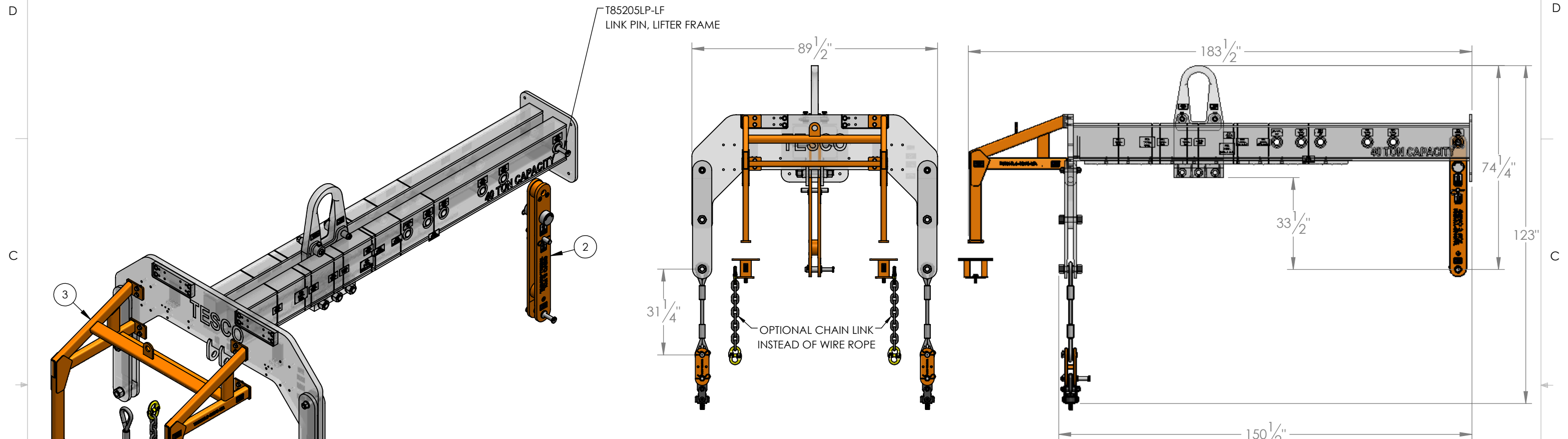

### T85205KT-GEVO-MA

#### GEVO MUFFLER ATTACHED KIT

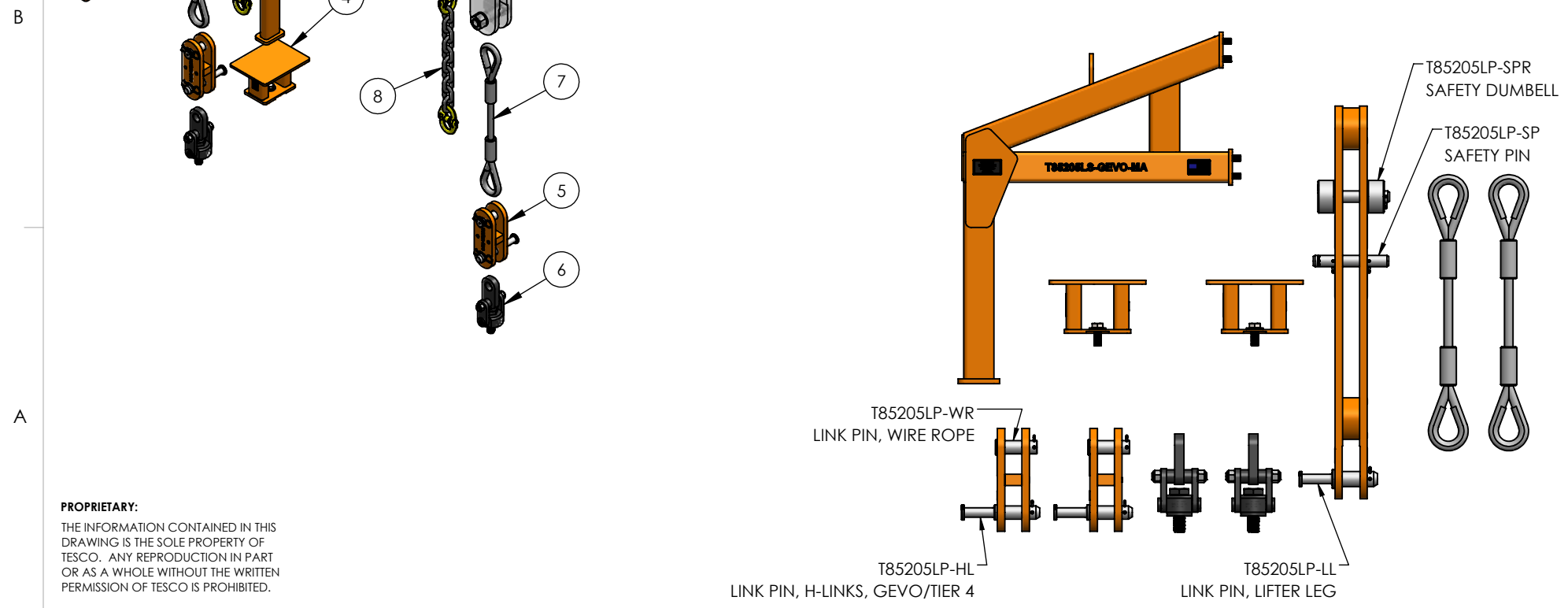

ITEM NO.	PART NUMBER	DESCRIPTION	QTY.
1	T85205	ENGINE LIFTER ASM F/EMD/FDL/GEVO/TIER 4	1
2	T85205LL-GEVOFDL	LIFTER LEG F/GEVO & FDL	1
3	T85205LS-GEVO-MA	GEVO LIFTER SUPPORT MUFFLER ATTACHED ASM	1
4	T85205LS-P	GEVO LIFTER SUPPORT PLATFORM ASM	2
5	T85205HL-GEVO	GEVO H-LINK	2
6	T85205SHR-GEVO	SWIVEL HOIST GEVO, M36	2
7	LC1320	1 1/8" X 34" Cable Assembly	2
8	T85205LC	ENGINE LIFTER CHAIN LINK	2

UNLESS OTHERWISE SPECIFIED:  
DIMENSIONS ARE IN INCHES  
TOLERANCES:  
FRACTIONAL: ± 1/64  
ANGULAR: MACH ± .5° BEND ± 1°  
ONE DECIMAL: .X = +0.1  
TWO PLACE DECIMAL: .XX = ±0.01  
THREE PLACE DECIMAL: .XXX = ±0.005  
INTERPRET GEOMETRIC TOLERANCING PER:  
ASME Y14.5-2009

COMPANY NAME  
**TESCO**  
TRANSPORTATION EQUIPMENT SUPPLY COMPANY  
8106 HAWTHORNE DRIVE  
ERIE, PA 16509  
(814) 866-1952

TOOL NAME  
GEVO ENGINE LIFTER MUFFLER ATTACHED

DWN BY CDS	DATE 1/20/2016	DWG. NO. GEVO-MA ENGINE LIFTER	REV
---------------	-------------------	-----------------------------------	-----

SIZE: B SCALE: 1:35 WT: 5544.51 lb SHEET 1 OF 1

**PROPRIETARY:**  
THE INFORMATION CONTAINED IN THIS  
DRAWING IS THE SOLE PROPERTY OF  
TESCO. ANY REPRODUCTION IN PART  
OR AS A WHOLE WITHOUT THE WRITTEN  
PERMISSION OF TESCO IS PROHIBITED.

8 7 6 5 4 3 2 1

**WARNING!**  
DO NOT EXCEED RATED CAPACITY  
INSPECT BEFORE EVERY USE. REPORT ANY  
OBSERVED DAMAGE AND REMOVE LIFTER  
FROM SERVICE. IMPROPER OPERATION  
MAY RESULT IN SERIOUS INJURY.

WLL/RATED LOAD: 80,000LBS

# GE EVOLUTION LOCOMOTIVE

## TIER 4 ENGINE LIFTER MUFFLER REMOVED

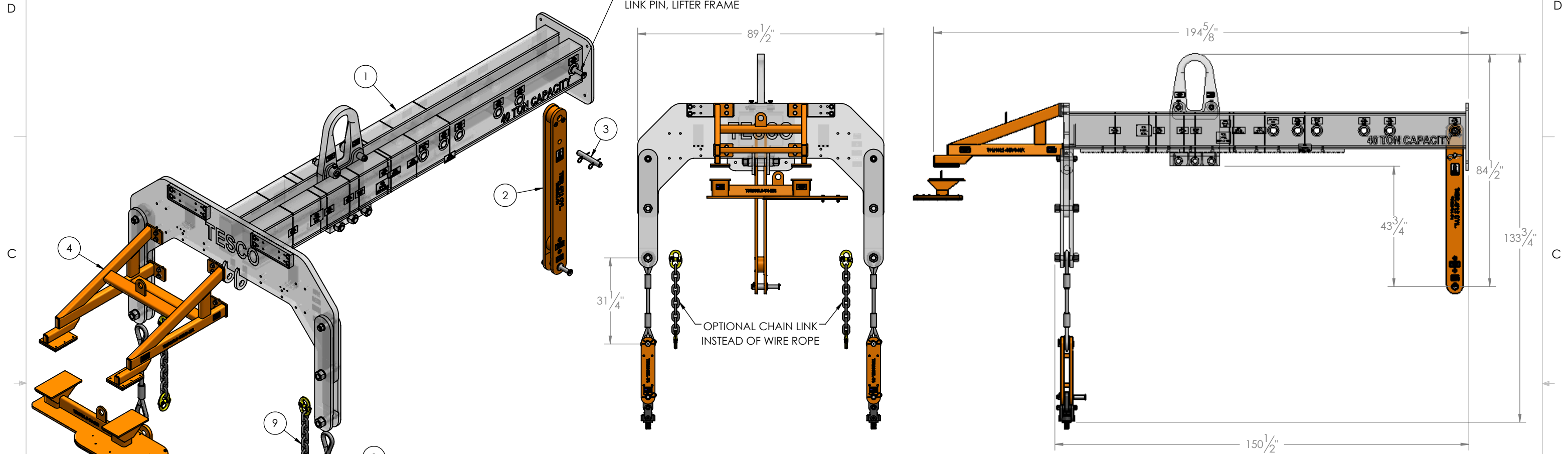

### T85205KT-T4-MR

#### TIER 4 MUFFLER REMOVED KIT

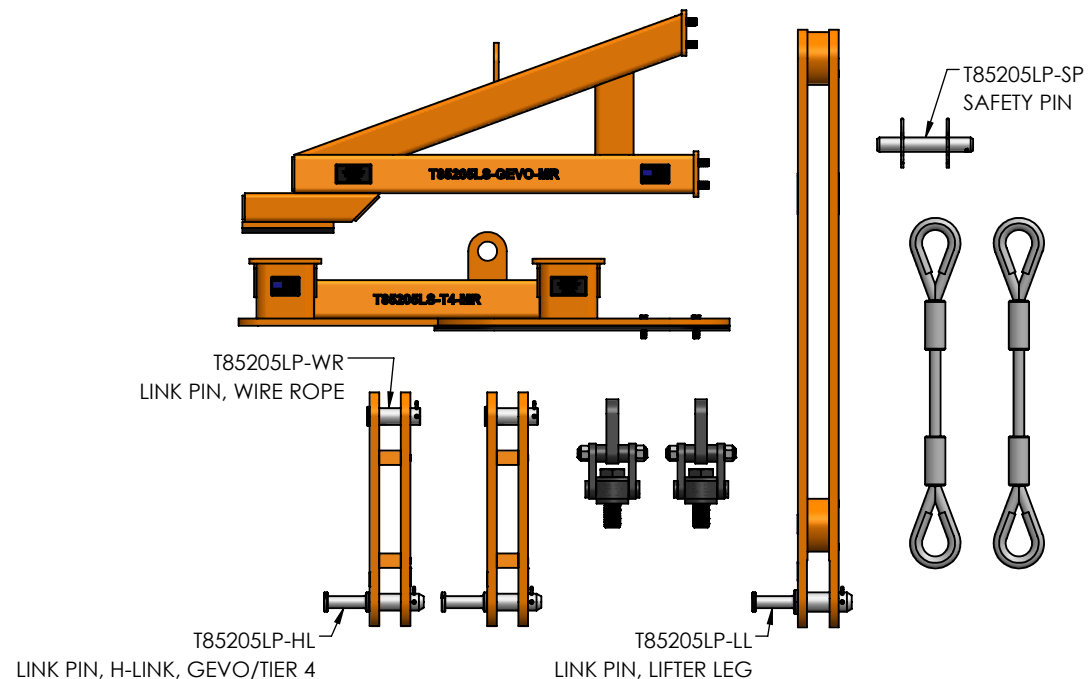

ITEM NO.	PART NUMBER	DESCRIPTION	QTY.
1	T85205	ENGINE LIFTER ASM F/EMD/FDL/GEVO/TIER 4	1
2	T85205LL-T4	TIER 4 ENGINE LIFTER LEG ASM	1
3	T85205LP-SP	SAFETY PIN ASM	1
4	T85205LS-GEVO-MR	GEVO LIFTER SUPPORT MUFFLER REMOVED ASM	1
5	T85205LS-T4-MR	TIER 4 LIFTER SUPPORT MUFFLER REMOVED ASM	1
6	T85205HL-T4	TIER 4 H-LINK ASM	2
7	T85205SHR-T4	SWIVEL HOIST TIER 4, M42	2
8	LC1320	1 1/8" X 34" Cable Assembly	2
9	T85205LC	ENGINE LIFTER CHAIN LINK	2

UNLESS OTHERWISE SPECIFIED:  
DIMENSIONS ARE IN INCHES  
TOLERANCES:  
FRACTIONAL: ± 1/64  
ANGULAR: MACH ± .5° BEND ± 1°  
ONE DECIMAL: .X = ± 0.1  
TWO PLACE DECIMAL: .XX = ± 0.01  
THREE PLACE DECIMAL: .XXX = ± 0.005  
INTERPRET GEOMETRIC TOLERANCING PER:  
ASME Y14.5-2009

COMPANY NAME  
**TESCO**  
TRANSPORTATION EQUIPMENT SUPPLY COMPANY  
8106 HAWTHORNE DRIVE  
ERIE, PA 16509  
(814) 866-1952

TOOL NAME  
GE TIER 4 ENGINE LIFTER MUFFLER REMOVED

DWN BY CDS	DATE 1/20/2016	DWG. NO. T4-MR ENGINE LIFTER	REV
---------------	-------------------	---------------------------------	-----

SIZE: B SCALE: 1:35 WT: 5766.12 lb SHEET 1 OF 1

**PROPRIETARY:**  
THE INFORMATION CONTAINED IN THIS  
DRAWING IS THE SOLE PROPERTY OF  
TESCO. ANY REPRODUCTION IN PART  
OR AS A WHOLE WITHOUT THE WRITTEN  
PERMISSION OF TESCO IS PROHIBITED.

**!WARNING!**  
DO NOT EXCEED RATED CAPACITY  
INSPECT BEFORE EVERY USE. REPORT ANY  
OBSERVED DAMAGE AND REMOVE LIFTER  
FROM SERVICE. IMPROPER OPERATION  
MAY RESULT IN SERIOUS INJURY.

WLL/RATED LOAD: 80,000LBS

# GE EVOLUTION LOCOMOTIVE

## TIER-4 ENGINE LIFTER MUFFLER ATTACHED

D

C

B

A

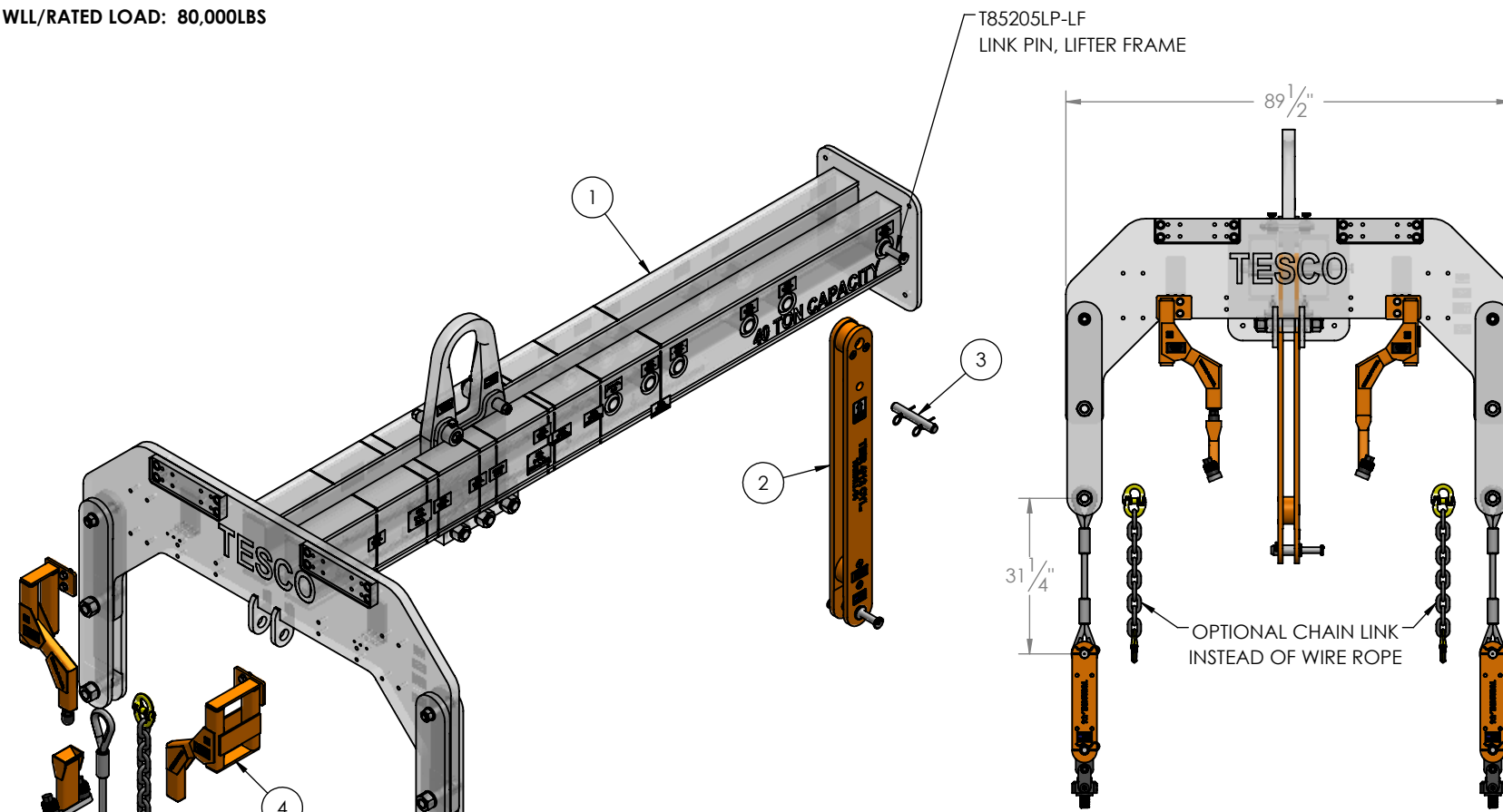

### T85205TK-T4-MA

#### TIER 4 MUFFLER ATTACHED KIT

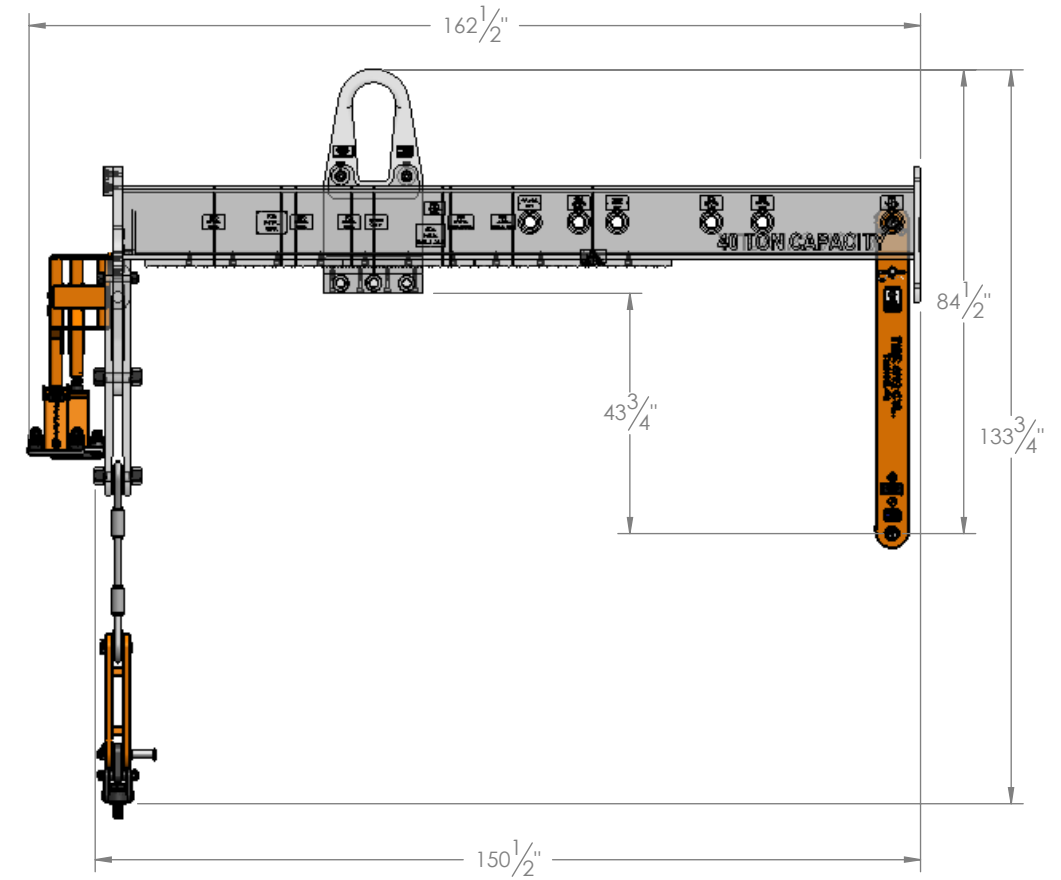
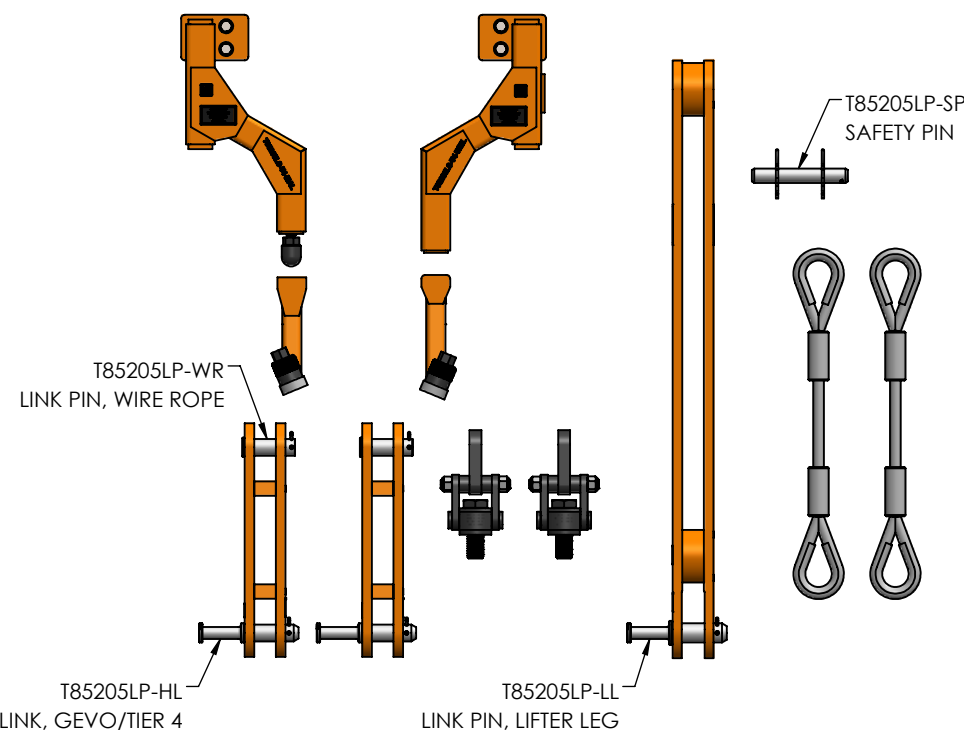

ITEM NO.	PART NUMBER	DESCRIPTION	QTY.
1	T85205	ENGINE LIFTER ASM F/EMD/FDL/GEVO/TIER 4	1
2	T85205LL-T4	TIER 4 ENGINE LIFTER LEG ASM	1
3	T85205LP-SP	SAFETY PIN ASM	1
4	T85205LS-T4-MAL	TIER 4 ENGINE LIFTER ADAPTER LEGS ASM	1
5	T85205LS-T4-MAP	TIER 4 CYLINDER STUD PLATFORM W/NUTS ASM	1
6	T85205HL-T4	TIER 4 H-LINK ASM	2
7	T85205SHR-T4	SWIVEL HOIST TIER 4, M42	2
8	LC1320	1 1/8" X 34" Cable Assembly	2
9	T85205LC	ENGINE LIFTER CHAIN LINK	2

UNLESS OTHERWISE SPECIFIED:  
DIMENSIONS ARE IN INCHES  
TOLERANCES:  
FRACTIONAL: ± 1/64  
ANGULAR: MACH ± .5° BEND ± 1°  
ONE DECIMAL: .X = +0.1  
TWO PLACE DECIMAL: .XX = ±0.01  
THREE PLACE DECIMAL: .XXX = ±0.005  
INTERPRET GEOMETRIC TOLERANCING PER:  
ASME Y14.5-2009

COMPANY NAME  
**TESCO**  
TRANSPORTATION EQUIPMENT SUPPLY COMPANY  
8106 HAWTHORNE DRIVE  
ERIE, PA 16509  
(814) 866-1952

TOOL NAME  
**GE TIER 4 ENGINE LIFTER MUFFLER ATTACHED**

DWN BY CDS	DATE 1/20/2016	DWG. NO. T4-MA ENGINE LIFTER	REV
---------------	-------------------	---------------------------------	-----

SIZE: B SCALE: 1:35 WT: 5432.76 lb SHEET 1 OF 1

**PROPRIETARY:**  
THE INFORMATION CONTAINED IN THIS  
DRAWING IS THE SOLE PROPERTY OF  
TESCO. ANY REPRODUCTION IN PART  
OR AS A WHOLE WITHOUT THE WRITTEN  
PERMISSION OF TESCO IS PROHIBITED.

8

7

6

5

4

3

2

1

D

C

B

A