

# HYDROTOOLS™

By **SWIMLINE®**

HYDROTOOLS by Swimline / ILP  
191 Rodeo Drive, Edgewood, New York 11717 | Tel: 1.631.254.2155 • Fax: 1.631.254.2363  
Email: [info@swimlinecorp.com](mailto:info@swimlinecorp.com) • [www.swimline.com](http://www.swimline.com)

# HYDROTOOLS™

By **SWIMLINE®**

**Models 8939 8939G Wide Mouth Thru-Wall Skimmer Instructions**

## INSTALLATION INSTRUCTIONS:

1. Begin by assembling the wide mouth extension to the skimmer housing using (8) SS Philips Head screws and the 8946 Gasket. The eight holes are the ones that are recessed in the extension piece. There are 2 holes on all four sides at the rear of the extension.
2. If pool wall **IS factory pre-cut** for a skimmer and return fitting follow these instructions, otherwise go to step 3 below.
  - a. Locate the wall opening, and punch out the (22) twenty two 1/4" holes, and rectangular cut out.
  - b. Find the pre-cut area for the return fitting and knock out the cut out.
  - c. With a file or piece of sandpaper remove any metal burrs that may cut the liner or yourself during the assembly.
  - d. Skip step 3 and go directly to step 4.
3. If the pool wall is **NOT factory pre-cut** for a skimmer and return follow these instructions.
  - a. Using the **Hole Template Guide**, locate the area against the metal wall at your desired position. (The water level should be approximately at the mid point of the face plate.) Be careful that the skimmer body and face plate will not interfere with the top coping or the lip of the pool structure.
  - b. Using the **Hole Template Guide** drawing for spacing details, drill (22) 1/4" holes. With a pair of tin snips cut a 5-5/8" x 12" opening in the wall, again using the drawing as a guide.
  - c. Next, find a desired location for the return fitting. The cutout should be approximately 8" below the desired water level. Cut a 2-3/8" diameter circle at the location.
  - d. With a file or piece of sandpaper remove any metal burrs that may cut the liner or yourself during assembly.
4. Skimmer Housing Installation procedure:
  - a. Select one of the 8905 hose adapters and screw into the bottom of the skimmer housing using the Teflon tape. **CAUTION:** these are pipe threads and over tightening can crack the housing. **Never use any type of glue or sealant on these threads.**
  - b. Place one of the 8917 Wide Mouth skimmer gaskets on the skimmer face, making sure that the holes in the gasket align with the holes in the skimmer face.
  - c. Align the skimmer face and gasket with the drilled holes in the wall panel and fasten with (4) four pan head screws. These are the 4 short screws in the hardware set. The holes are located on the top and bottom of the housing. They are the 3rd hole in from each side of the housing.
  - d. Install the vinyl liner according to the swimming pool manufacturer's instruction. **Do not cut any holes in the liner at this time.** Fill the pool to approximately 2" below the return fitting before proceeding to the next steps. Adjust the liner as necessary as pool is filling.
  - e. Align the second 8917 gasket and face plate (8918).
  - f. You should have a sandwich of materials between the face plate and the skimmer housing as follows: the 8918 Face plate, 8917 gasket, the vinyl liner, the metal wall panel, 8917 gasket and finally the skimmer housing Wide Mouth extension.
  - g. Fasten tightly to the skimmer face with the 18 remaining stainless steel Philips head screws. Alternate tightening screws from left to right and top to bottom.
  - h. Connect the filter hose on the suction side of your filtration unit to the 8905 hose adapter on the bottom of the skimmer housing. Secure with a hose clamp.

**(If air is getting into your pump system while you are filtering or vacuuming your pool. Check the hose connections between the skimmer housing and pump inlet for an airtight fit and that you have a good seat with the hose adapters by using the Teflon tape on all pipe threads, or check water level to make sure it's at least midway up on the face plate)**

- i. Using the skimmer face plate as a guide, use a razor blade or sharp knife to trim only the liner, being careful not to cut the gasket.

### 5. Return Fitting Installation Procedure:

- a. Gently press the vinyl liner at the circular wall-fitting opening to locate the exact position. Make a circular cutout in the vinyl approximately 3/4" smaller than the opening in the wall.
- b. Disassemble the 8949 return fitting.
- c. Screw the remaining 8905 hose adapter into the return fitting opposite of the flange end. Use the Teflon tape for a sealant. **Use caution not to over tighten as it may crack the fitting. Never use any type to glue or sealant on the pipe threads.**
- d. Place one of the rubber gaskets, from the 3 pc gasket set, on the fitting and insert through the vinyl liner and wall panel. The eyeball side should be inside the pool. Next, place the cork gaskets followed by the rubber gasket over the rear of the fitting and screw the locknut hub up tightly.
- e. Screw the adjustable directional ball fitting into the flange side of the fitting. Direct the flow of water away from the skimmer opening.
- f. Connect the return hose to the pressure side of your filtration system. Secure with a hose clamp.

## OPERATING INSTRUCTIONS:

1. Make sure you keep the water level in the pool midway up the face plate. If the water level falls below the recommended level, water may cavitate in the housing and cause the pool pump to lose its prime.
2. To adjust the inlet flow direction loosen the knurled outer ring of the "eyeball" portion and move the ball to the desired position.
3. To clean the 8928-skimmer basket, remove the 8927 top cover; and remove the basket. It is recommended that the pool pump be shut off.
4. To vacuum the pool follow these directions:
  - a. Remove the top cover or fold the 8926-weir flap forward and squeeze pins toward the center and remove. It is not necessary to remove the 8928 basket.
  - b. Fill your vacuum hose with water by temporarily inserting the hose cuff into the return fitting while the pool pump is on. Make sure all the air is removed from the hose.
  - c. Take the 8929 Vac adapter, which consists of the plate and elbow, and attach to the hose through the opening of the wall and place down inside the housing. Try to keep the hose cuff submerged during this process so no air gets back into the hose to cause the pump to cavitate and lose its prime.

## WINTERIZING PROCEDURE:

Drain pool level approximately 2" to 4" below skimmer opening. Remove the "eyeball" fitting in return and securely plug wall fitting with 1-1/2" plugs from your dealer. Disconnect filter hoses from the skimmer and wall fitting. Be sure that the skimmer is kept free from water accumulation.

**Your warranty does not cover damages caused by the formation of ice in the skimmer housing.**

## PARTS LIST:

Model 8939 / 8939G Wide Mouth Thru-Wall Skimmer System includes:

- Skimmer Housing
- Wide Mouth Extension
- 8918 Wide Mouth Face Plate
- 8927 Locking Top Cover
- 8926 Flap Weir
- 8928 Basket
- 8929 Vac Adapter Plate & Elbow
- 8949 Return Fitting including "Eyeball" and Gaskets
- (2) 8905 Hose Adapters 1-1/4" and 1-1/2"
- 8917 Wide Mouth Skimmer Gasket Set (2 Pcs.)
- Stainless Steel Philips Screw Set (30) Pcs.- (26) #10 x 1" flat Philips heads and (4) #10 x 5/8" short pan heads
- 8948 Roll Teflon Tape

## EXPLODED VIEW:

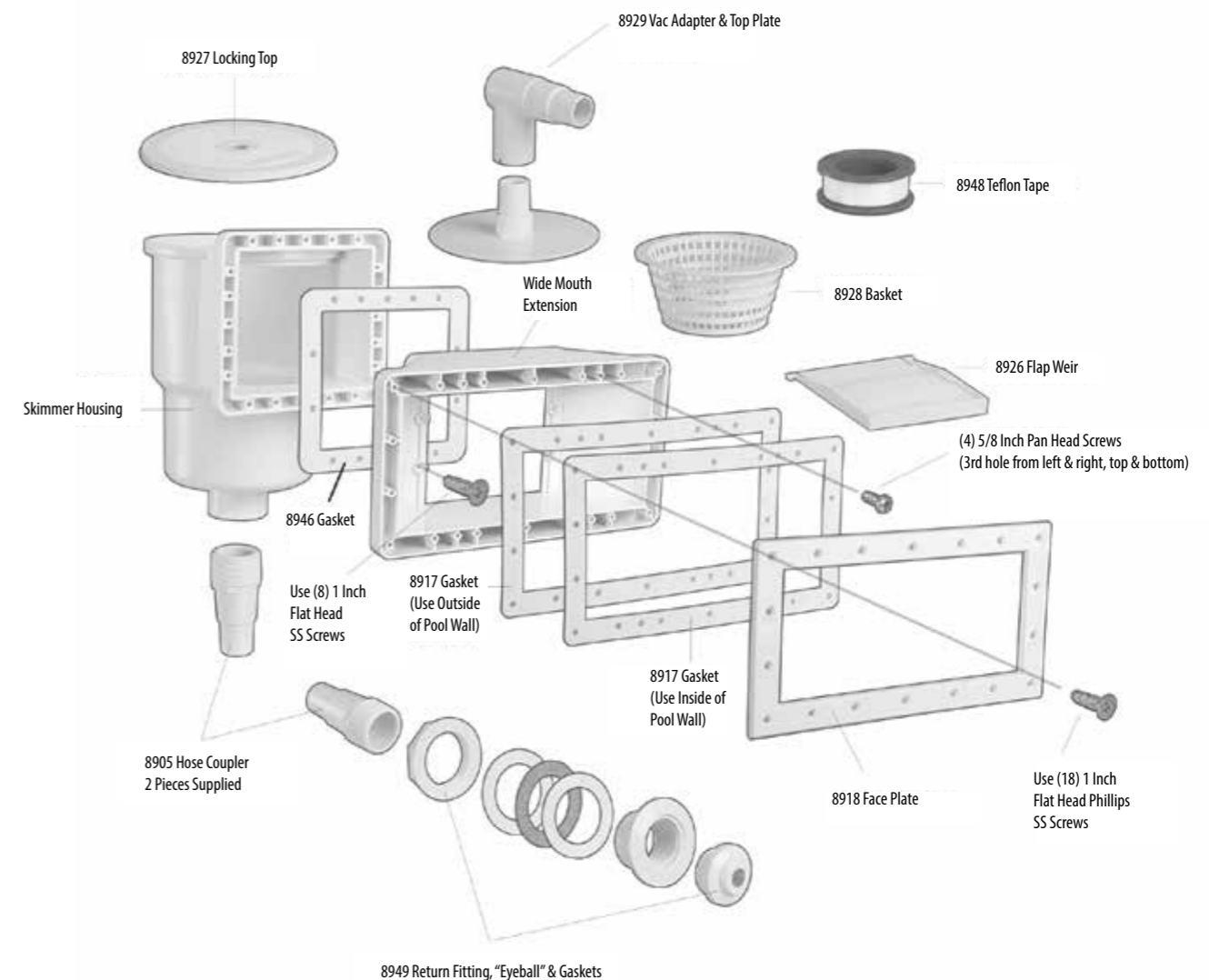

8939, 8939G, 8939A, 8939AG Template

TOP  
HAUT  
ARRIBA

