



***PROFILE  
DESIGN***

---

**ASC SERIAL EXTENSIONS**

REVISION 01-02-16-2024

## INTRODUCTION

**Thank you for purchasing this set of Profile Design Aerobar Extensions. These instructions apply to the ASC series.**

Please read these instructions thoroughly before attempting to install this item. Proper installation is required for compliance with Profile Design's warranty policy. If you are not familiar with installation of Aerobars or their accessories, please seek the assistance of your local Profile design dealer by logging on to [www.profile-design.com](http://www.profile-design.com) and using "dealer search" or by calling Profile Design's customer service number p.# 888.800.5999.

**Note to Dealers: If you install this product for the consumer, please provide him/her with this owner's manual after installation.**

### Tools and materials required:

- Assembly compound such as Finish Line Fiber Grip™
- Cutting guide
- Hacksaw with a 32T blade for Carbon Extensions
- Half round file
- Electrical/Insulation tape
- Clean, lint free cloth

## **Your Extension kit should contain:**

- Two (2) extensions (Carbon)
- Two (2) grip end bar plugs
- Two (2) cable exit bar plugs

## **Optional accessories compatible with these extensions:**

- Aeria II Series Brackets
- Sonic Series Brackets

**If anything is missing from the extension kit please contact your dealer.**

**WARNING: Periodically check the extension for damage, particularly for scratches through the clearcoat (carbon parts) that could lead to degradation and weakening of the base material. Replace your extension if you notice any damage from use or accident.**

# COMPONENT LIST

43ASC 400mm

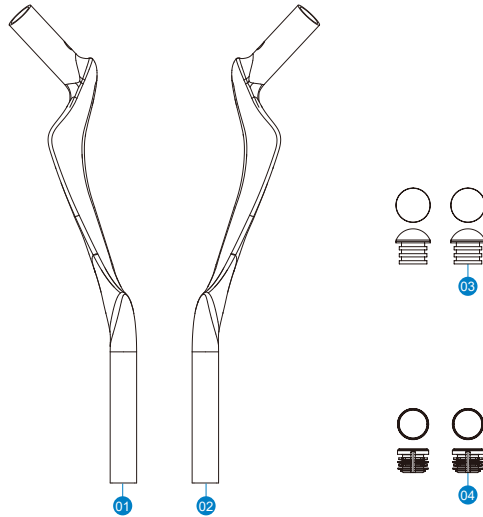

Ref.#	Part.#	QTY. Req.	Part Description
1	852289	1	43ASC 400mm - Left(A)
2	852290	1	43ASC 400mm - Right(B)
3	716669	2	End Plug - Front
4	716667	2	End Plug - Rear

43ASC 340mm

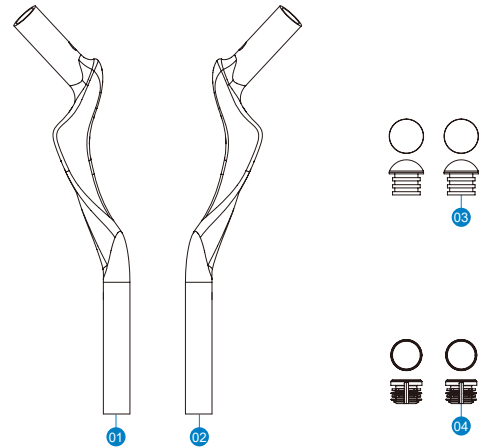

Ref.#	Part.#	QTY. Req.	Part Description
1	852291	1	43ASC 340mm - Left(A)
2	852292	1	43ASC 340mm - Right(B)
3	716669	2	End Plug - Front
4	716667	2	End Plug - Rear

# COMPONENT LIST

**52ASC 400mm**

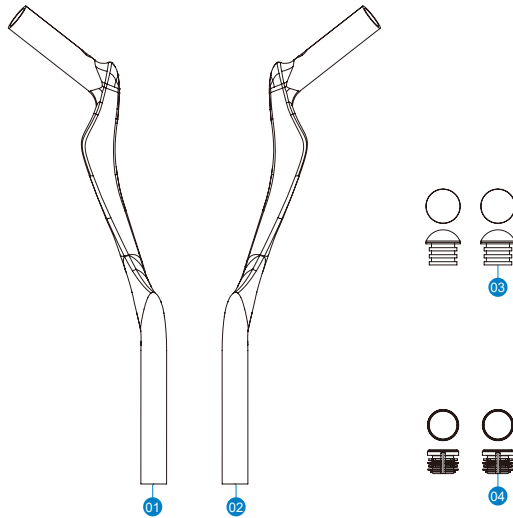

Ref.#	Part.#	QTY. Req.	Part Description
1	852303	1	52ASC 400mm - Left(A)
2	852304	1	52ASC 400mm - Right(B)
3	716663	2	End Plug - Front
4	716674	2	End Plug - Rear

**52ASC 340mm**

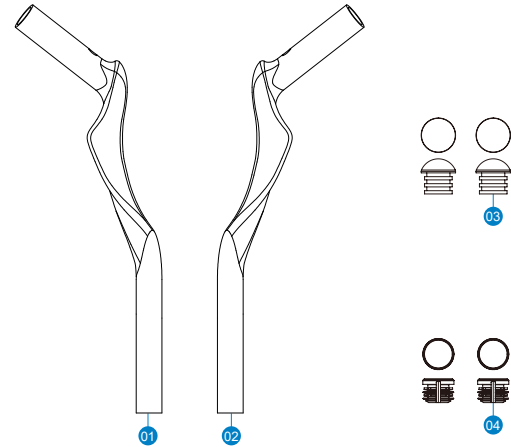

Ref.#	Part.#	QTY. Req.	Part Description
1	852301	1	52ASC 340mm - Left(A)
2	852302	1	52ASC 340mm - Right(B)
3	716663	2	End Plug - Front
4	716674	2	End Plug - Rear

# PART DRAWINGS

**43ASC 400mm**

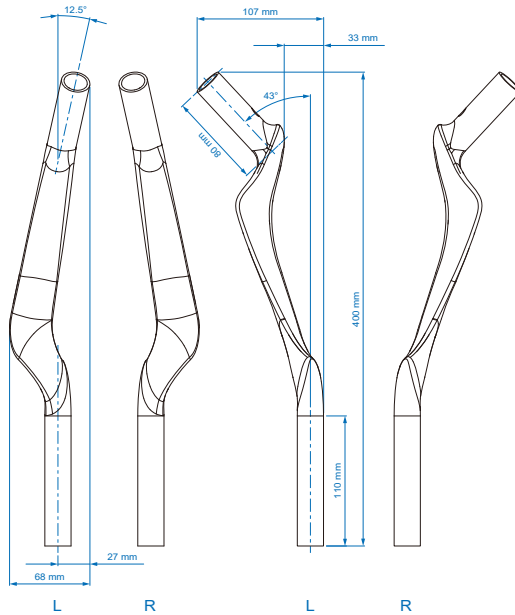

**43ASC 340mm**

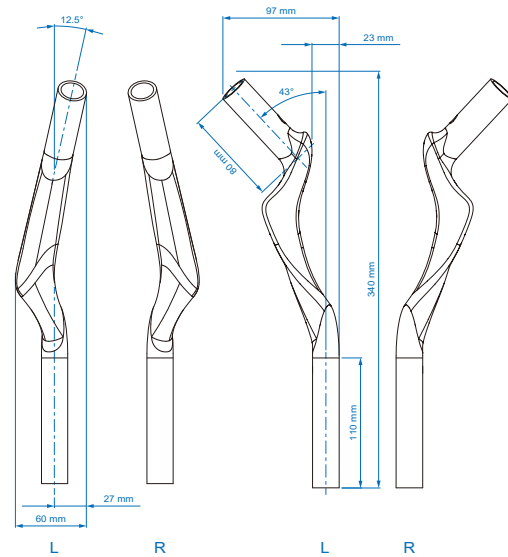

# PART DRAWINGS

**52ASC 400mm**

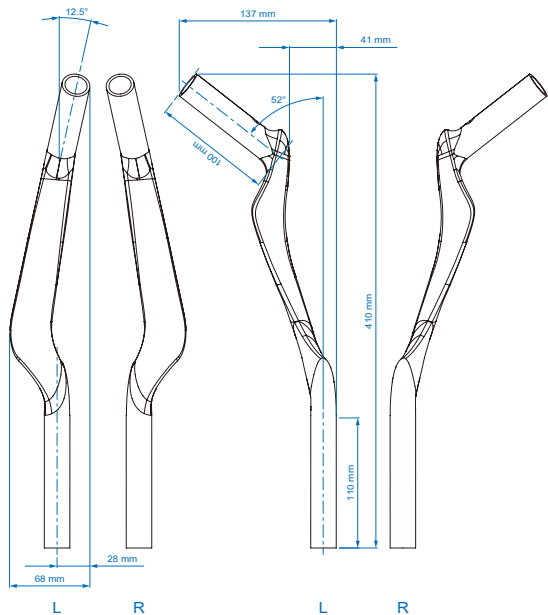

**52ASC 340mm**

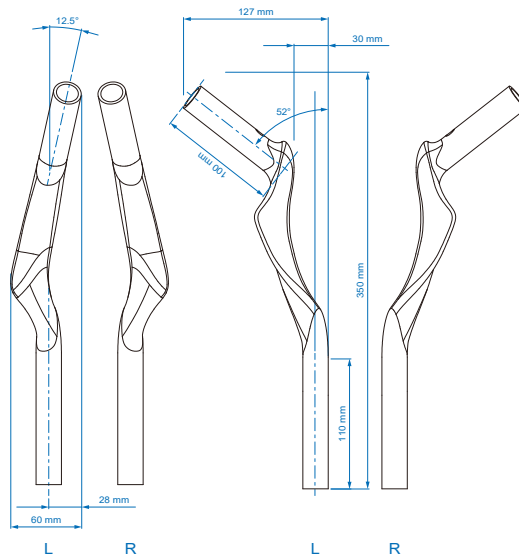

## PRODUCT SPECIFIC SETUP LIMITATIONS

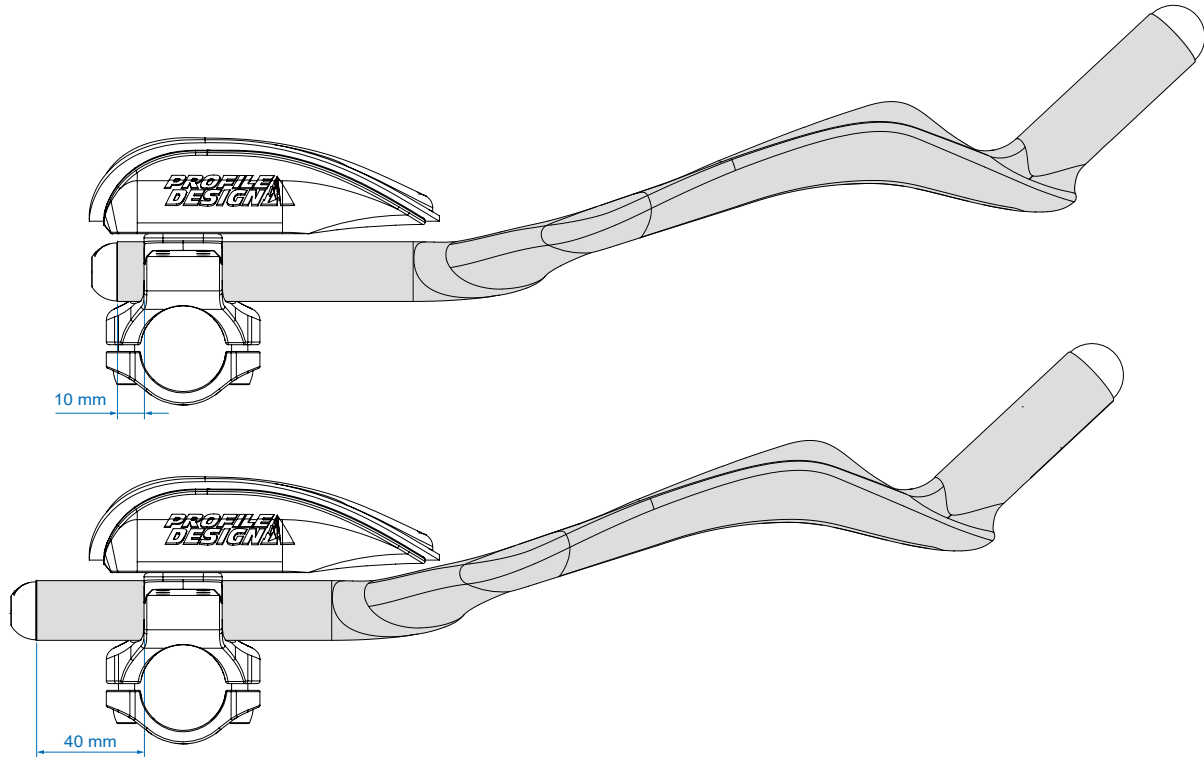



# TORQUE SETTINGS

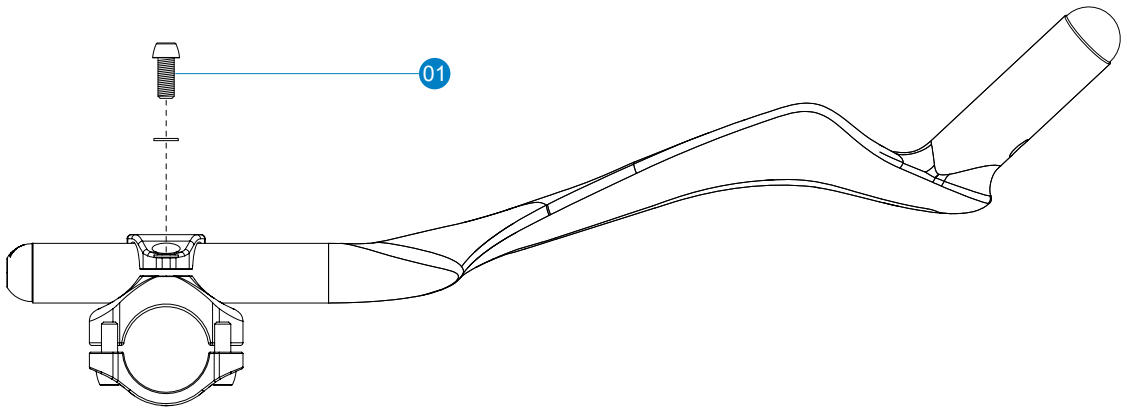



Ref.#	Location	Bolt Size	Torque
1	Extension clamp	M6x15mm	6Nm (53 inlbf)

# INSTALLATION INSTRUCTIONS

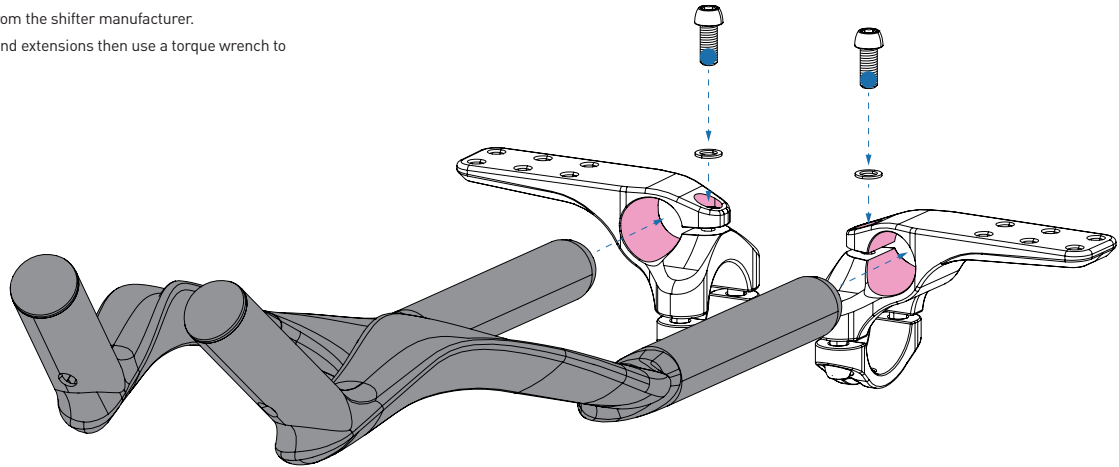
1. Install the extensions in the desired position and tighten the extension fixing bolt so they are held snugly.
2. Install the shifters as per the shifter manufacturer's instructions. We recommend a light coating of assembly compound on the inside of the extension prior to installing the shifter.
3. Install the cables as per instructions from the shifter manufacturer.
4. Check the placement of the brackets and extensions then use a torque wrench to tighten the extension clamp.



 Assembly compound  
 Threadlocker

## HOW TO CUT THE EXTENSIONS

1. Carefully determine the required extension length by performing a bike fit or measuring the existing extensions.
2. Mark the point at which you wish to make a cut.
3. We recommend checking your measurements after first marking the cut line to ensure that you do not inadvertently cut the extensions too short.
4. Mount the cutting guide securely in a vice. Then place the extension in the guide and line up the marked cut line with the slot in the cutting guide.
  - a. For carbon a 32T or carbon specific blade is recommended. Wrap the extension with insulation tape at the cut line to limit the risk of splintering the carbon at the blade exit point.
  - b. When cutting carbon, wear a breathing mask, gloves and eye protection then dispose of the dust residue carefully. Airborne dust particles are a respiratory hazard.
5. Using the hacksaw, make firm strokes of the blade through the guide, allowing the blade to do the work. Do not apply excessive force to the hacksaw as you risk snapping the blade and the possibility of injury.
6. Repeat the process for the second extension.
7. Once you have cut both extensions, use the half round file to remove any sharp edges from both the interior and exterior faces of the extension.

## **WARRANTY POLICY**

- Profile Design Worldwide Two Year Limited Warranty.
- Profile Design, LLC (distributor) warrants to the original retail purchaser ("you") that the Profile Design product for which you received this warranty is free from defects in material and workmanship for (2) two years from the date of original retail purchase. For more details on this warranty, its exclusions and/or how to make a claim under the warranty please call +1 310.747.0085 extension 161 or visit [www.profile-design.com/pages/warranty](http://www.profile-design.com/pages/warranty)



2677 El Presidio Street  
Long Beach, CA 90810  
Ph: 310-884-7756

[www.profile-design.com](http://www.profile-design.com)

© Profile Design LLC