



**PROFILE
DESIGN**

AERIA¹ EVO AEROBAR

REVISION 01-02-28-2019

INTRODUCTION

Thank you for purchasing this Profile Design bar. These instructions apply to the Aeria' Evo complete bar with Ergo armrests and 35a extensions.

Please read these instructions thoroughly before attempting to install this item. Proper installation is required for compliance with Profile Design's warranty policy. If you are not familiar with the installation of aerobars or their accessories, please seek the assistance of your local Profile Design dealer by logging on to www.profile-design.com and using "Dealer Locator" or by calling Profile Design's customer service number p.# 888.800.5999.

Note to Dealers: If you install this product for the consumer, please provide him/her with this owner's manual after installation.

Tools and materials required:

- 5mm Hex Wrench
- 4mm Hex Wrench
- Torque Wrench with a 4mm and 5mm Hex fitting
- Assembly compound
- Lithium grease
- Isopropyl alcohol
- Cutting guide and hacksaw (18T blade for Aluminium, 32T for Carbon) Or a pipecutter for aluminium
- Half round file
- Electrical/Insulation tape
- Clean, lint free cloth

Optional accessories compatible with this aerobar:

- Profile Design Aeria¹ riser kit
- Boom or Race armrests
- Other extensions from the Profile Design range – 45/25a and 50a
- Older generation armrests – F35, F22, F19
- Older generation extensions – T1, T2, T3, T4, T5 add V2, V4 extensions in carbon and aluminium

If anything is missing from the aerobar kit please contact your dealer.

Please note that threaded areas have been pre-treated by Profile Design during production with a special blue thread locking compound. This special compound is easy to detect on the threads of all bolts provided. If you cannot detect this thread locking compound or you are re-installing the bolt, re-apply a suitable blue thread locking compound as available from Loctite® or another company before assembly.

Periodically check the aerobars for damage, particularly for scratches through the anodised coating that could lead to oxidation and weakening of the aluminum. Replace your aerobars if you notice any damage from use or accident.

AEROBAR COMPONENTS PARTS

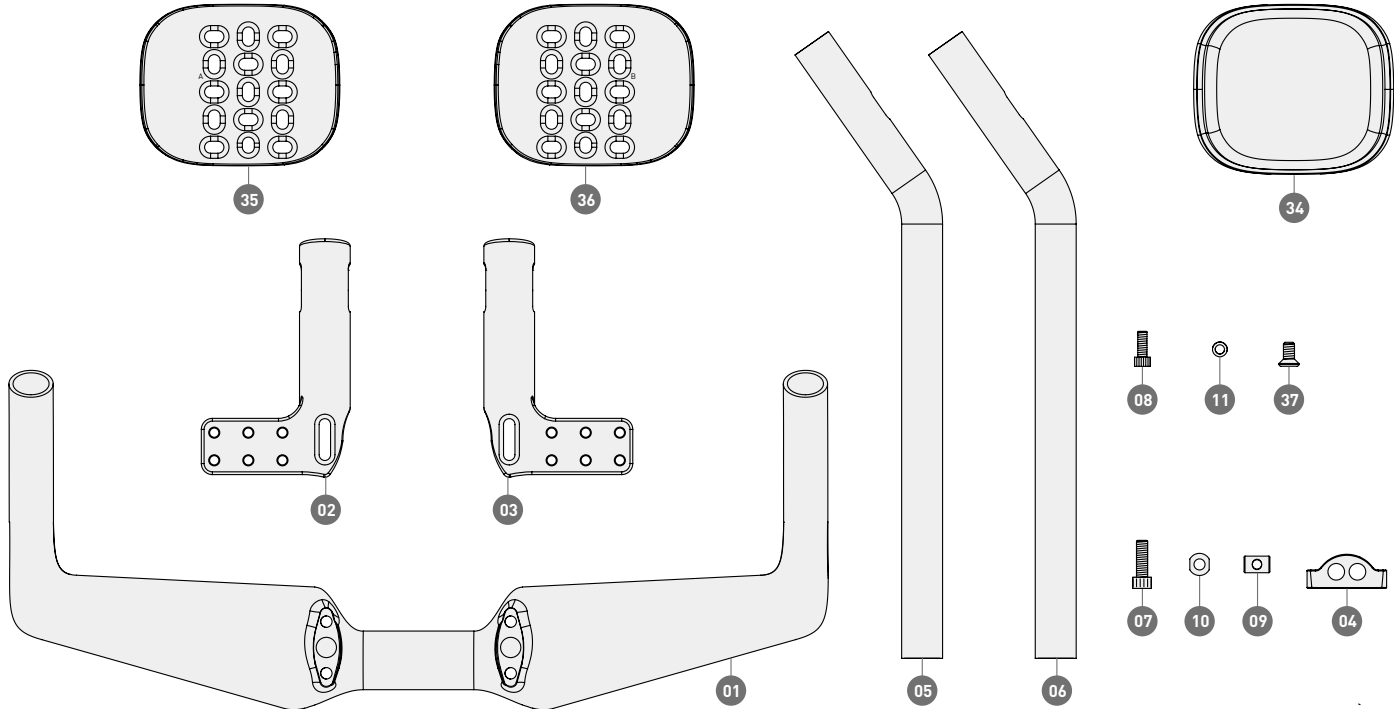

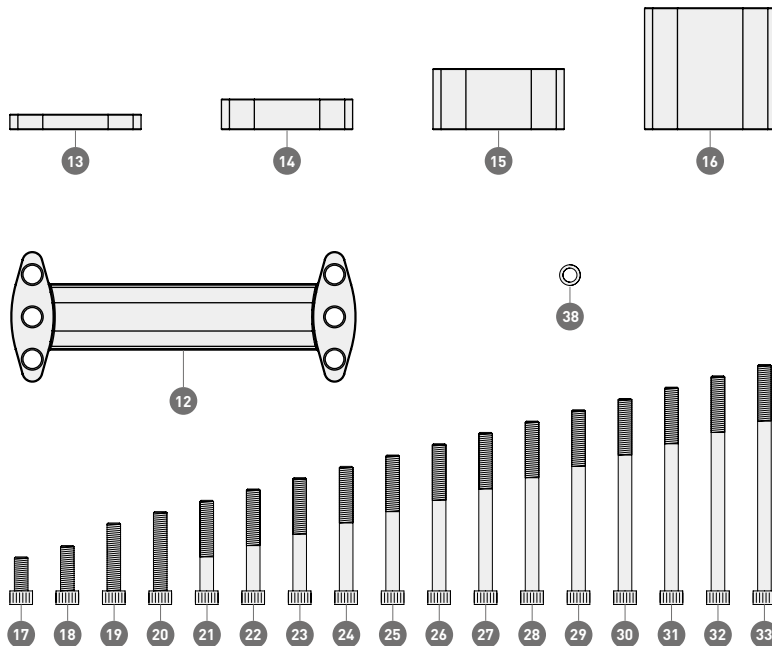

Ref.#	Part#	QTY. Req.	Part Description
1	852254	1	Basebar - Aeria1 EVO 42cm Carbon UD-Matte BK w/LV BK Logo
2	189370	1	Bracket - Aeria EVO Top bracket Flat BK w/LV BK Logo Left
3	189371	1	Bracket - Aeria EVO Top bracket Flat BK w/LV BK Logo Right
4	189372	2	Bracket - Aeria EVO Bottom bracket Flat BK
5	852245	1	Extension - 35a 340mm Side A Black Logo
6	852246	1	Extension - 35a 340mm Side B Black Logo
7	313528	4	Bolt - M6x20 SHB
8	313573	2	Bolt - M5x14 SHB
9	274461	4	Pin new RM1 System w/ Groove
10	275474	4	Washer - 6x12x1.5 UCP
11	275565	2	Washer - M5 Silver
12	483189	1	Riser - Aeria Bridge 5mm Flat Black
13	293120	2	Riser - 5mm Aeria Flat Black
14	293121	2	Riser - 10mm Aeria Flat Black
15	293122	2	Riser - 20mm Aeria Flat Black
16	293123	2	Riser - 40mm Aeria Flat Black
17	313525	4	Bolt - M6x15mm SHB
18	313528	4	Bolt - M6x20mm SHB
19	313531	4	Bolt - M6x25mm SHB
20	313532	4	Bolt - M6x30mm SHB
21	313530	4	Bolt - M6x35mm SHB Half thread
22	313533	4	Bolt - M6x40mm SHB Half thread
23	313534	4	Bolt - M6x45mm SHB Half thread
24	313535	4	Bolt - M6x50mm SHB Half thread
25	313537	4	Bolt - M6x55mm SHB Half thread
26	313538	4	Bolt - M6x60mm SHB Half thread
27	313539	4	Bolt - M6x65mm SHB Half thread
28	313540	4	Bolt - M6x70mm SHB Half thread
29	313541	4	Bolt - M6x75mm SHB Half thread
30	313542	4	Bolt - M6x80mm SHB Half thread
31	313543	4	Bolt - M6x85mm SHB Half thread
32	313544	4	Bolt - M6x90mm SHB Half thread
33	313548	4	Bolt - M6x95mm SHB Half thread
34	485215	2	PAD - RACE/ERGO 10mm L/R
35	200062	1	Armrest - ERGO W/Hook Sticker Side A
36	200063	1	Armrest - ERGO W/Hook Sticker Side B
37	313593	4	Bolt - M6x12 FHB Stainless [SUS304]
38	550006	4	Washer - M6x9x0.8 SS

PART DRAWINGS

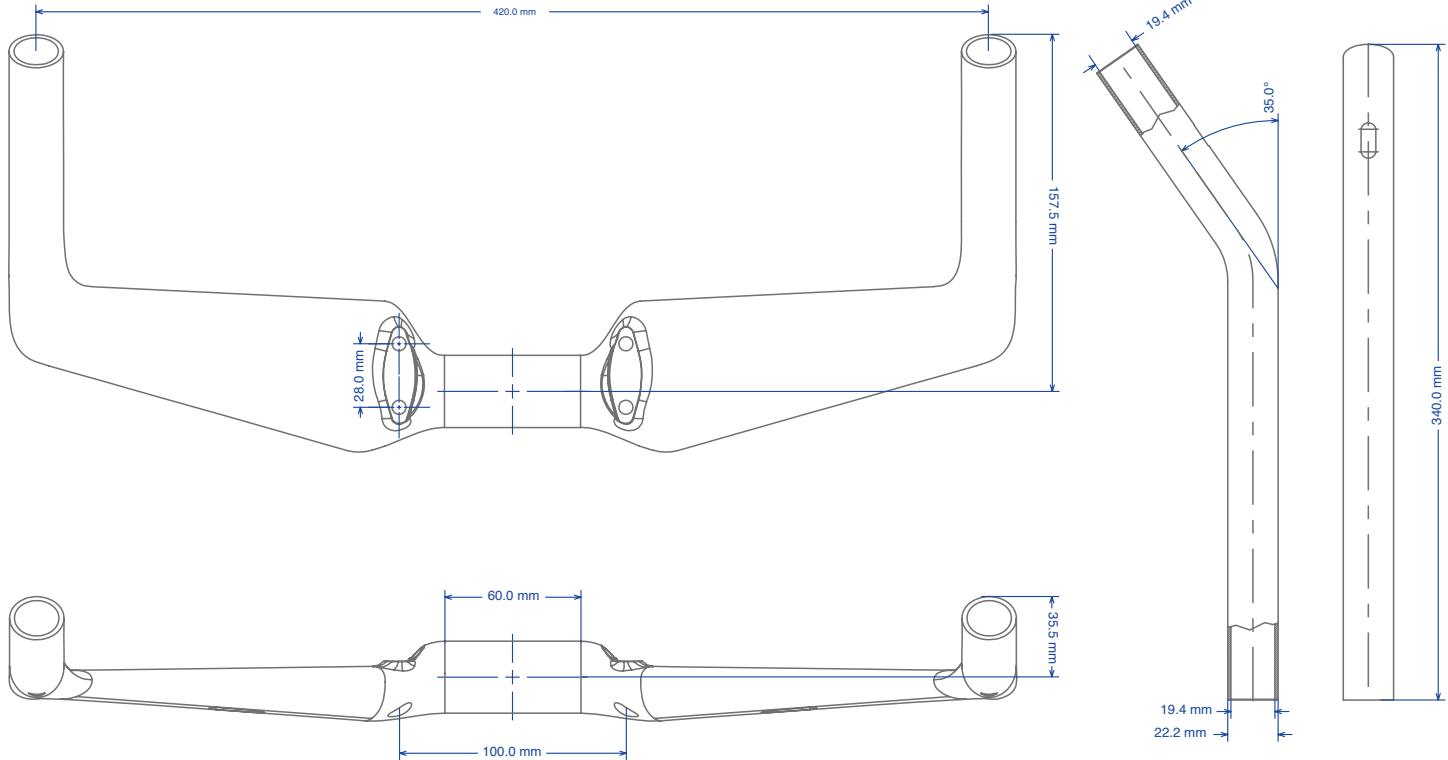

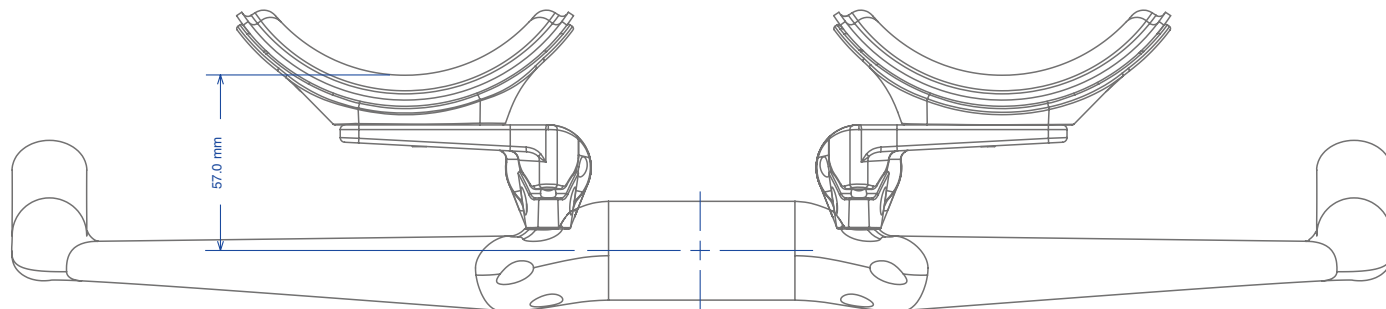
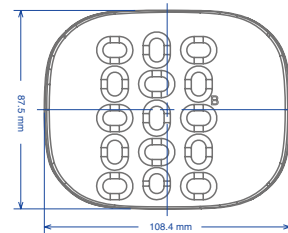
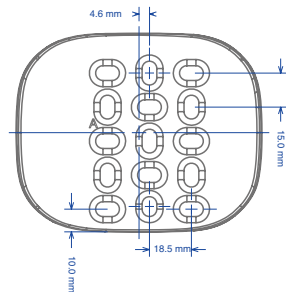
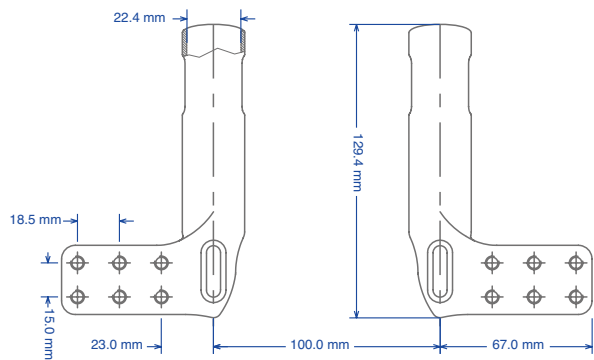

MAXIMUM EXTENSION LENGTH

Please note that the maximum length from the rear of the bracket to the tip of the extensions is 430mm.

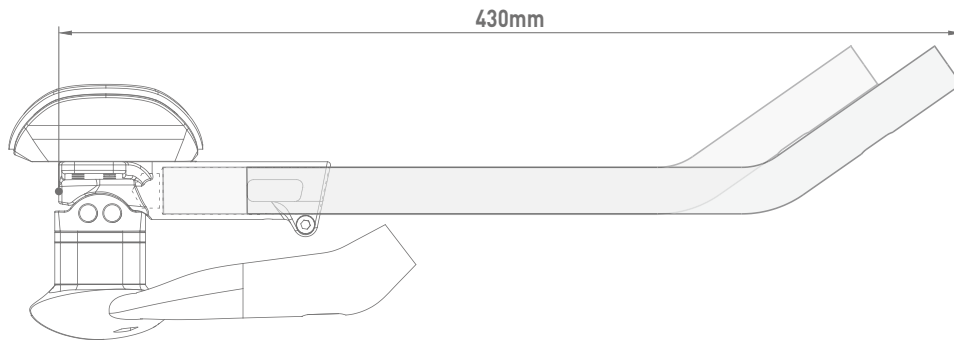

Minimum insertion - the extension must completely fill the window in the bracket.

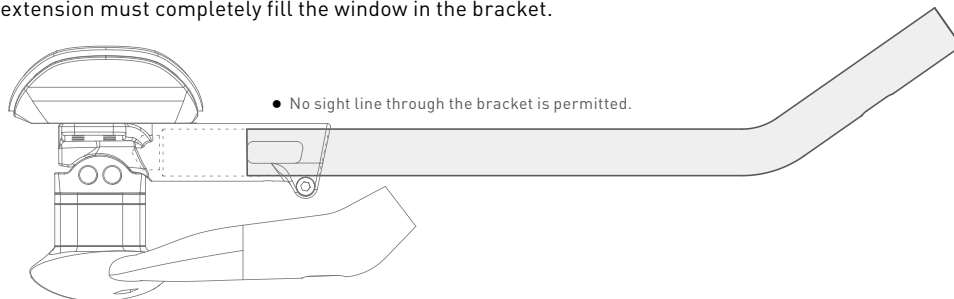

TORQUE SETTINGS

Ref.#	Location	Bolt Size	Torque
1	Basebar mount	M6x15mm	6Nm [53 inlbf]
2	Barrel mount	M6x20mm	6Nm [53 inlbf]
3	Extension clamp	M5x14mm	5Nm [44 inlbf]
4	Armrest Bolts	M6x13mm CS	4.7Nm [42 inlbf]
5	Stem Clamp		6Nm Max

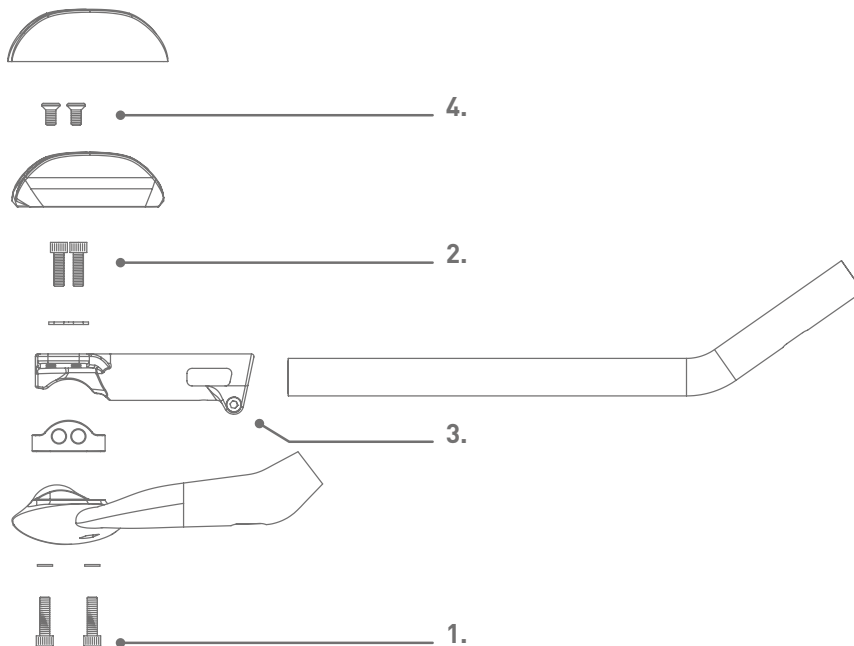

BOLT LENGTHS

- Aerobar Stack is the height of the top of the pads above the centre of the basebar including the cushion.
- Note that the bridge, if used, counts as a 5mm spacer.
- The Bridge should be used for spacer heights above 40mm
- The table shows the aerobar stack with different armrest choices:

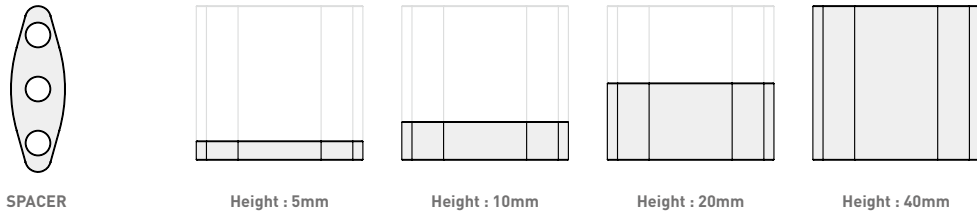

⚠ Only use Profile Design supplied bolts.

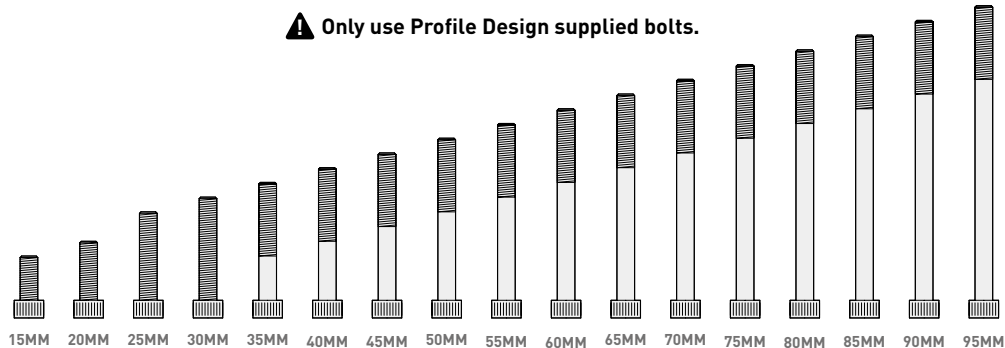

BOLT LENGTHS

Aerobar Stack		Spacer Height (mm)	Spacers Used	Bolt Length (mm)
Ergo/Race 10mm	Ergo/Race 5mm			
57	52	0	0	15
62	57	5	5	20
60	55	10	10	25
65	60	15	5, 10	30
70	65	20	20	35
75	70	25	5, 20	40
80	75	30	10, 20	45
85	80	35	5, 10, 20	50
90	85	40	40	55
95	90	45	40, Bridge	60
100	95	50	5, 40, Bridge	65
105	100	55	10, 40, Bridge	70
110	105	60	5, 10, 40, Bridge	75
115	110	65	20, 40, Bridge	80
120	115	70	5, 20, 40, Bridge	85
125	120	75	10, 20, 40, Bridge	90
130	125	80	5, 10, 20, 40, Bridge	95

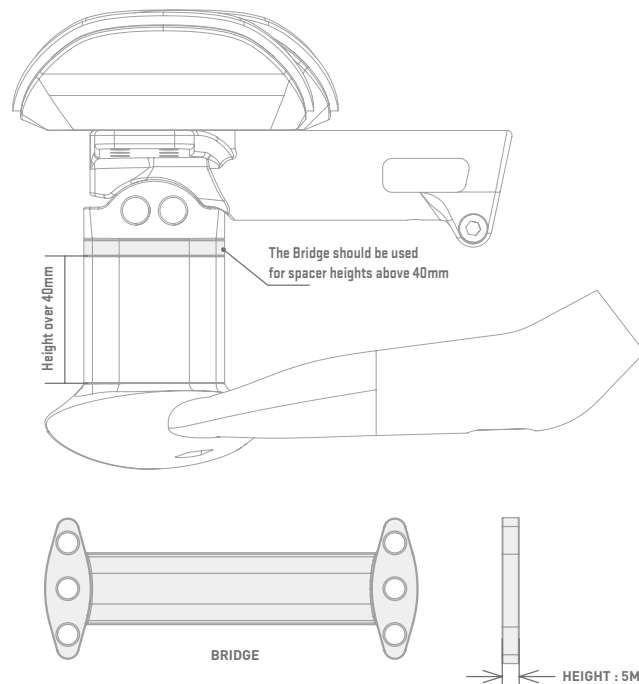

INSTALLATION INSTRUCTIONS

1. Apply a thin coating of assembly compound to the surface of the stem clamping area on the basebar.
2. Fit the stem to the basebar, torquing the bolts evenly to 5Nm.

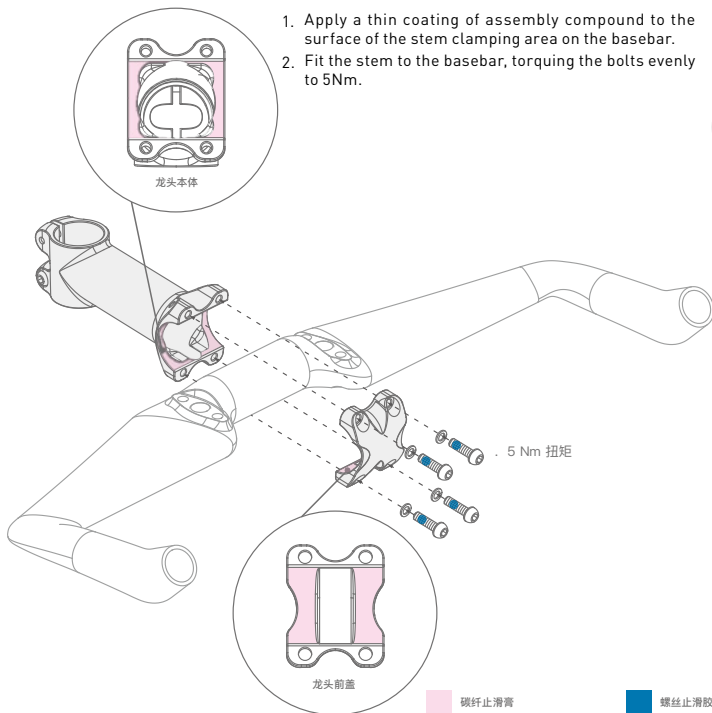

3. Apply a thin coating of lithium grease to the surface of the bracket mount on the basebar.
4. Mount the lower bracket and risers using the bolt lengths (with washers) specified in the bolt lengths table. (Refer to page 11.)
5. Use the Torque wrench with 5mm Hex to tighten the bolts to 6Nm.

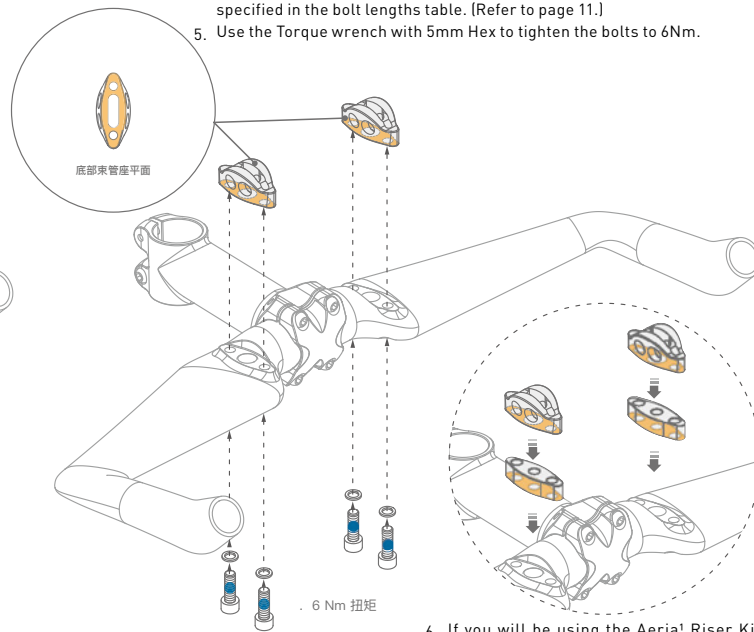

6. If you will be using the Aeria¹ Riser Kit apply lithium grease to all of the faces of the risers.

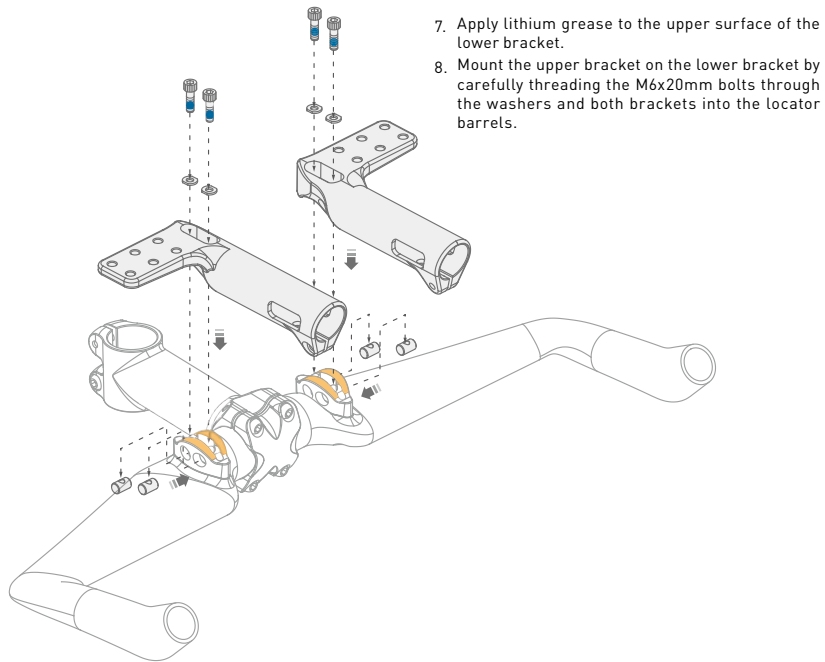

9. Adjust the angle of the bracket by altering the depth of the bolts in the barrels.
10. Once you are satisfied with the angle and have matched both sides, use the Torque wrench with 5mm Hex to tighten the bolts to 6Nm.

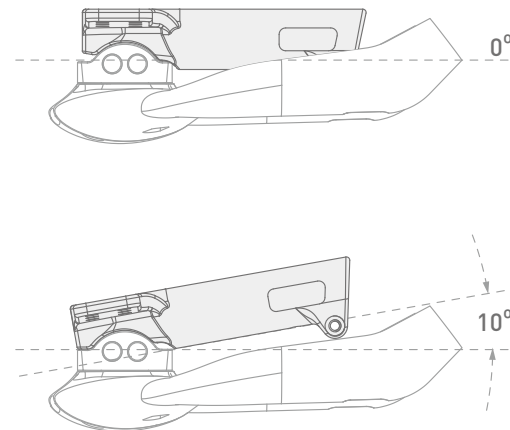

ASSEMBLY COMPOUND

THREADLOCKER

LITHIUM GREASE

11. To install the extensions in an aerobar bracket, first apply a light coating of assembly compound to the inner faces of the extension clamp.
12. Install the extensions in the desired position and tighten the M5 extension fixing bolt using the 4mm Hex wrench so they are held snugly.

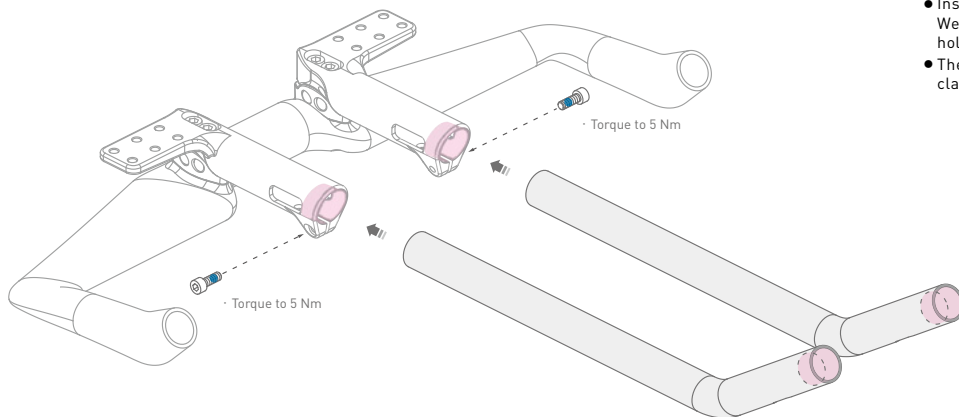

- Install the shifters (if using bar end models) as per the shifter manufacturer's instructions. We recommend a light coating of assembly compound on the inside of the extension prior to installing the shifter.
- Install the cables as per instructions from the shifter manufacturer. We suggest routing the cables by pushing through from the cable exit hole on the bracket.
- Then use the torque wrench with a 4mm fitting to tighten the extension clamp to 5Nm.

ASSEMBLY COMPOUND

THREADLOCKER

LITHIUM GREASE

13. Carefully determine the required extension length by performing a bike fit or measuring the existing extensions.

- The Aeria¹ Evo bracket allows 40mm of extension length adjustment beyond the minimum insertion. We recommend cutting the extensions 20mm longer than the minimum insertion point so you have room to both shorten and lengthen the extensions easily.
- The windows in the bracket show the minimum insertion – you must not be able to see through the extension shaft.

14. Apply a thin layer of lithium grease to the surface of the wing mount.

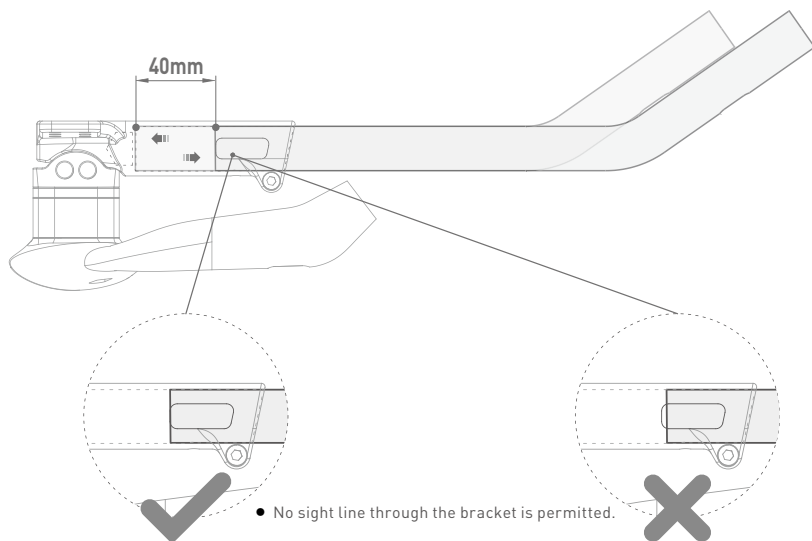

How to cut the extensions

1. Mark the cut line on the extensions.
2. We recommend checking your measurements after first marking the cut line to ensure that you do not inadvertently cut the extensions too short.
3. If using a cutting guide mount it securely in a vice. Then place the extension in the guide and line up the marked cut line with the slot in the cutting guide.
 - For aluminium an 18 tooth blade is recommended. Along with eye protection.
 - For carbon a 32T or carbon specific blade is recommended. Wrap the extension with insulation tape at the cut line to limit the risk of splintering the carbon at the blade exit point.
4. If cutting carbon, wear a breathing mask, gloves and eye protection then dispose of the dust residue carefully. Airborne dust particles are a respiratory hazard
5. Using the hacksaw, make firm strokes of the blade through the guide, allowing the blade to do the work. Do not apply excessive force to the hacksaw as you risk snapping the blade and the possibility of injury.
6. Alternately, if you are using a pipe cutter (only on aluminium extensions) – first apply insulation tape either side of the cut line to protect the finish of the extension from the rotating wheels.
7. Line the cutter up carefully with the cut line then rotate with a smooth motion, gradually depressing the cutting wheel further as the cut depth increases.
8. Repeat the process for the second extension.
9. Once you have cut both extensions, use the half round file to remove any sharp edges from both the interior and exterior faces of the extension.

15. Fasten the armrests to the brackets using the M6x13mm or M6x10mm countersunk bolts, note that the Ergo, Race and Boom armrests have an offset design so care is required to ensure each side is positioned in the same way.
16. Apply a light coating of Lithium grease to the surface of the bolts as a protective layer against the effects of sweat.
17. Attach the cushion by placing carefully on hook and loop backing of the armrest and hold firmly for 30 seconds. Repeat for the other armrest. Note that the cushions on these models of armrest are symmetrical, so it doesn't matter which side each cushion is applied to.

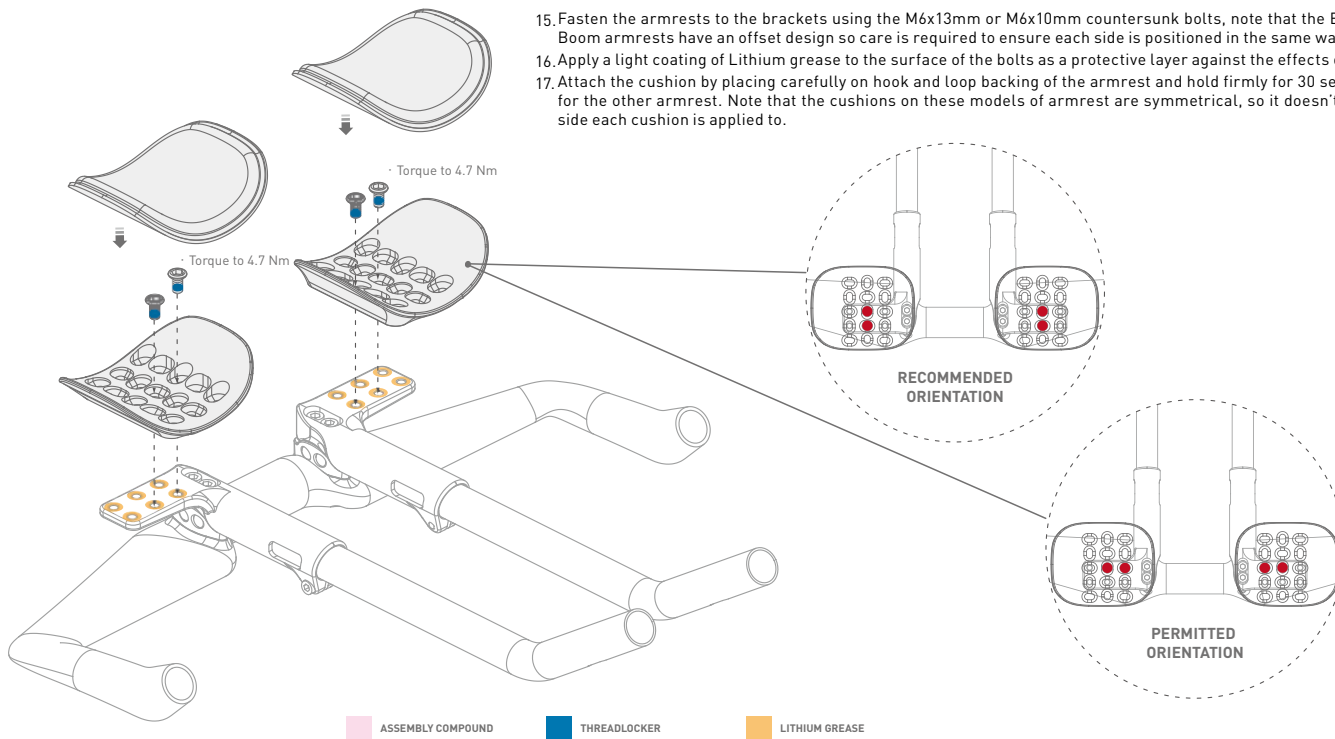

How to Install new armrests

1. To fit the armrests first ensure the inner face of the armrest is free of lint and grease, if the armrest has previously had a hook and loop sticker applied the residue should first be removed either mechanically or with a citrus based solvent.
2. Before applying the hook and loop sticker, you may choose to wipe down the surface with isopropyl alcohol to ensure good adhesion. Remove the backing from the hook and loop sticker and apply it to the armrest, smoothing the sticker out to ensure there are no air bubbles trapped under it.
3. Allow the sticker 24 hours to cure before use.

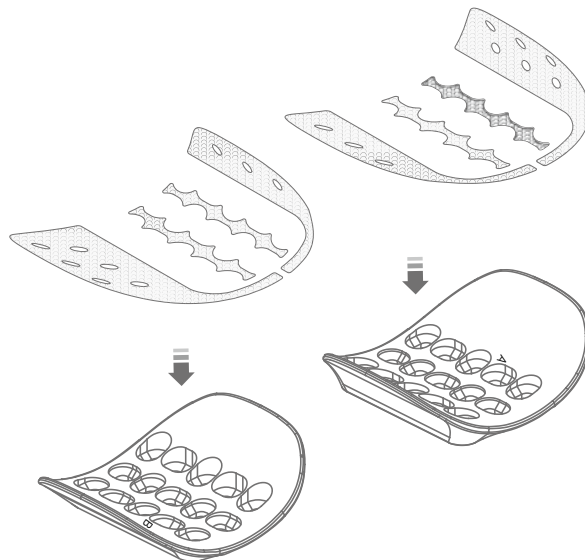
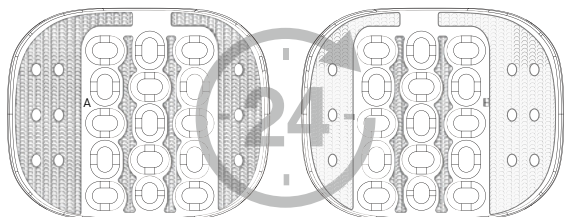

ARMREST USAGE

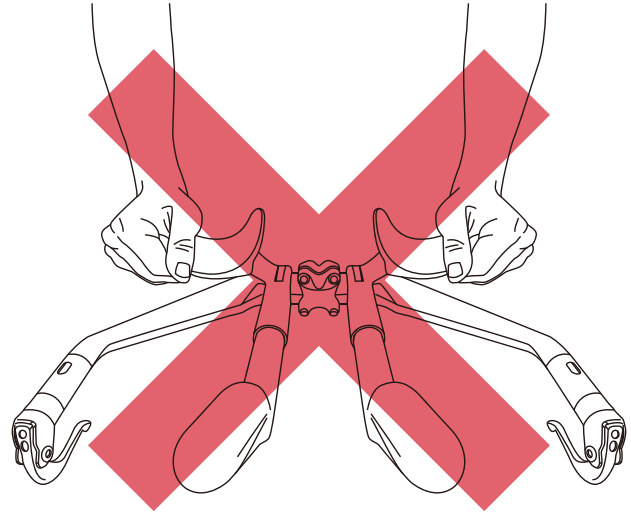
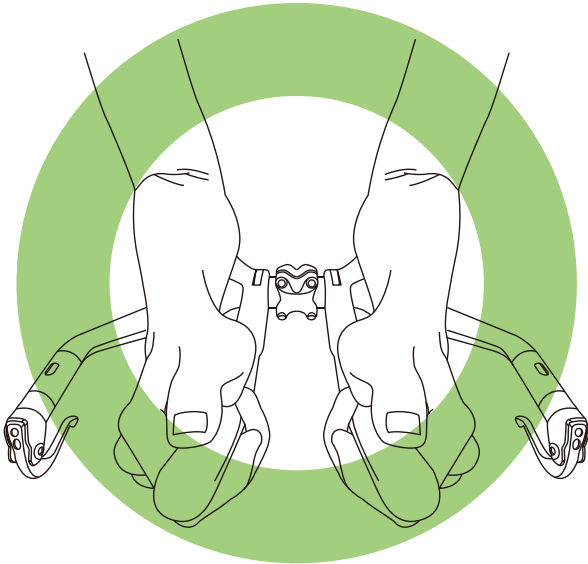

⚠ WARNING

Do not put force on the side of the armrests!

CABLE ROUTE MAP

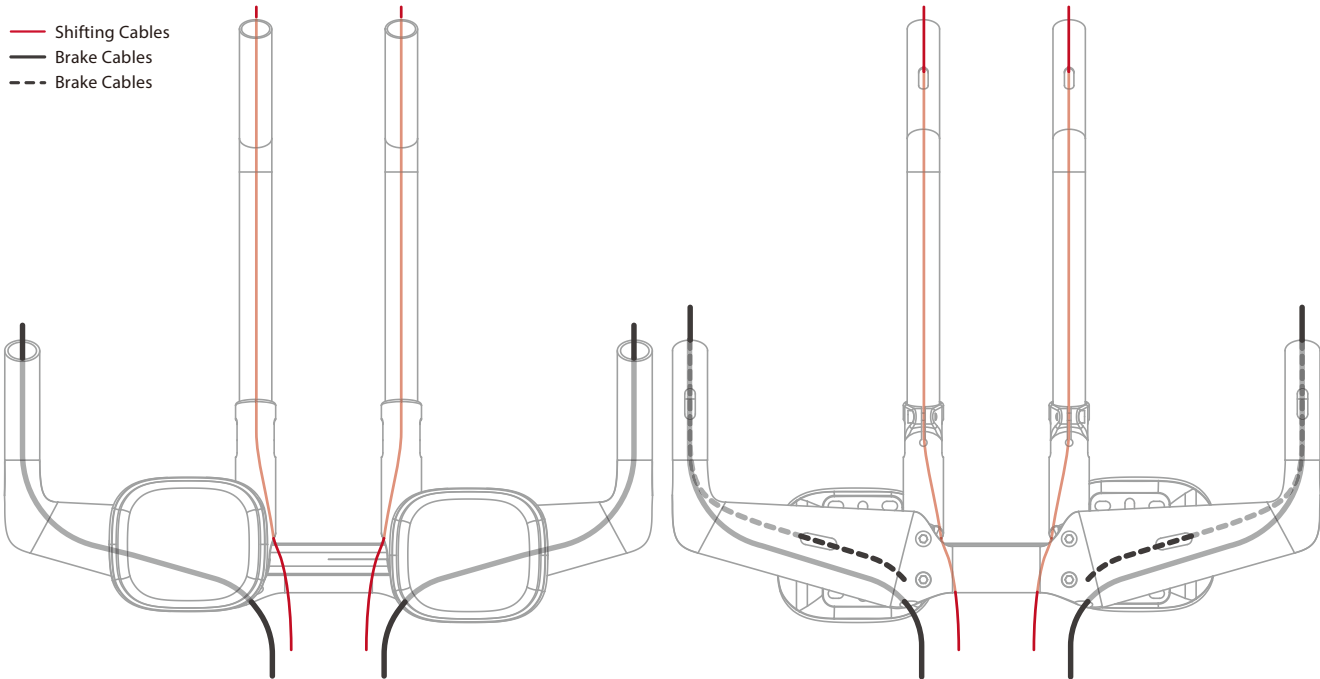

WARNING

- Profile Design Worldwide Two Year Limited Warranty.
- Profile Design, LLC (distributor) warrants to the original retail purchaser ("you") that the Profile Design product for which you received this warranty is free from defects in material and workmanship for (2) two years from the date of original retail purchase.
For more details on this warranty, its exclusions and/or how to make a claim under the warranty please call +1 310.747.0085 extension 161 or visit www.profile-design.com/pages/warranty



2677 El Presidio Street
Long Beach, CA 90810
Ph: 310-884-7756

www.profile-design.com

© Profile Design LLC