



GMR TUBELESS READY DISC BRAKE CLINCHER WHEELSETS

VERSION 01-03-30-2020

INTRODUCTION

Thank you for purchasing this Profile Design Wheelset. These instructions apply to the 26mm wide Disc brake compatible GMR series Tubeless Clincher rims with depths of 38, 50 and 65mm

Please read these instructions thoroughly before attempting to install this item. Proper installation is required for compliance with Profile Design's warranty policy. If you are not familiar with installing wheels or their accessories, please seek the assistance of your local Profile design dealer by logging on to www.profile-design.com and using "dealer search" or by calling Profile Design's customer service number p.# 888.800.5999.

Note to Dealers: If you install this product for the consumer, please provide him/her with this owner's manual after installation.

Tools and materials required:

- Cassette Tool
- Tire Levers
- Floor pump with pressure gauge
- Clean, lint free cloth

If setting the wheels up tubeless

- Sealant such as Finishline Tubeless Tire Sealant
- Sealant injector tool such as the Effetto Mariposa Caffelatex Latex Injector
- Charging chamber equipped pump such as the Blackburn Chamber or an air compressor

Your Wheelset should contain:

- Tubeless valves
- Tubeless Rim Strip(s)
- 10 Speed Cassette spacer– only included with rear wheels or wheelsets (as these wheels are designed for SRAM, Shimano and Campagnolo 11 speed cassettes)

If anything is missing from the wheelset please contact your dealer.

IMPORTANT SAFETY INFORMATION AND WARNINGS

Before each ride check to ensure:

- Each quick release or Through-Axle is properly adjusted, closed and the wheel is properly seated and aligned in each dropout so that brakes and shifting work properly.
- Brakes are properly functioning and adjusted.
- Wheel is “true” (does not wobble from side to side or “hop” up and down when rotated on the bike) and rotates freely.
- Spokes/nipples are not damaged, bent or of improper tension (check by applying finger tension to all spokes and comparing tension between them).
- There is no visible damage to the carbon surfaces of the rim or brake track.
- Tires (proper size) are properly inflated and evenly mounted and have no surface cuts, abrasions, bulges, cracking or other irregularities.
- If the wheelset fails any of these checks **DO NOT** use the wheel.

PART DRAWINGS

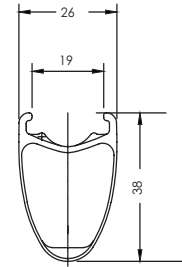
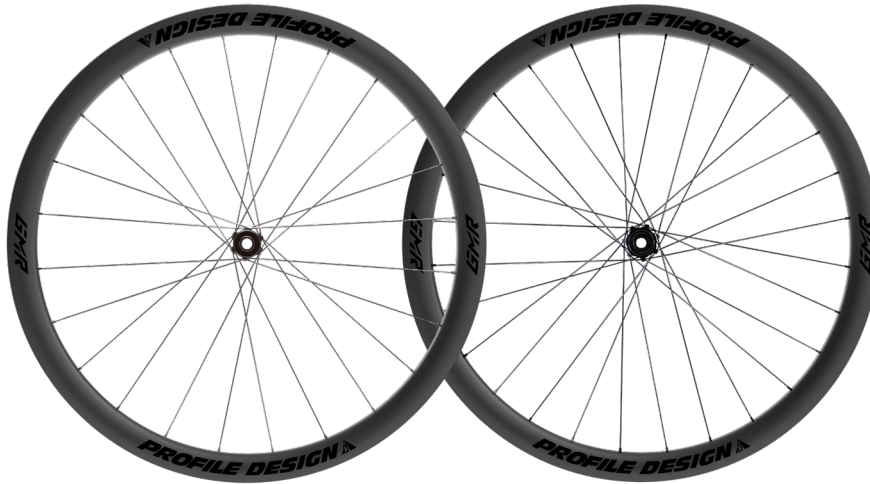

3826TL

PART DRAWINGS

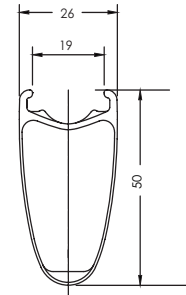
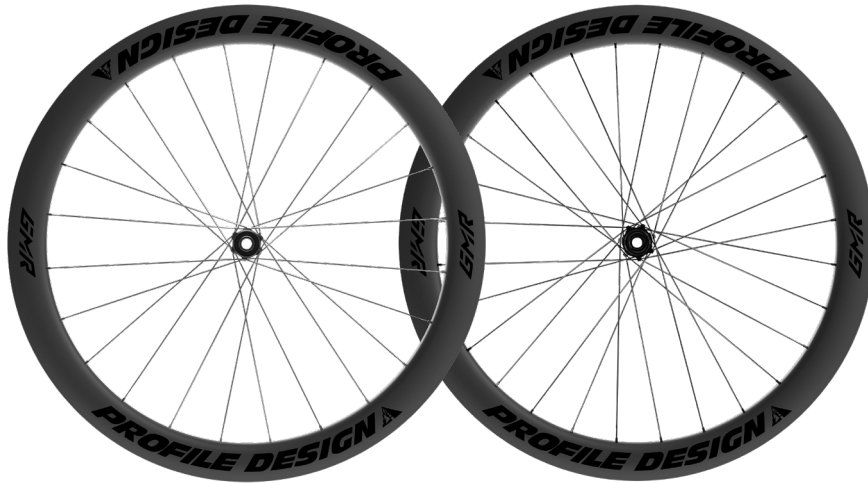

5026TL

PART DRAWINGS

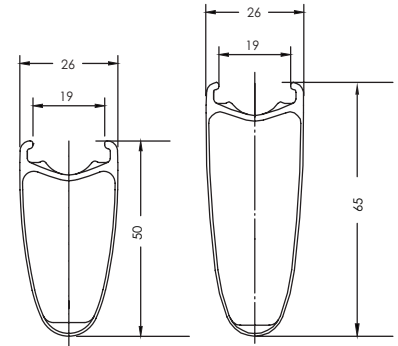
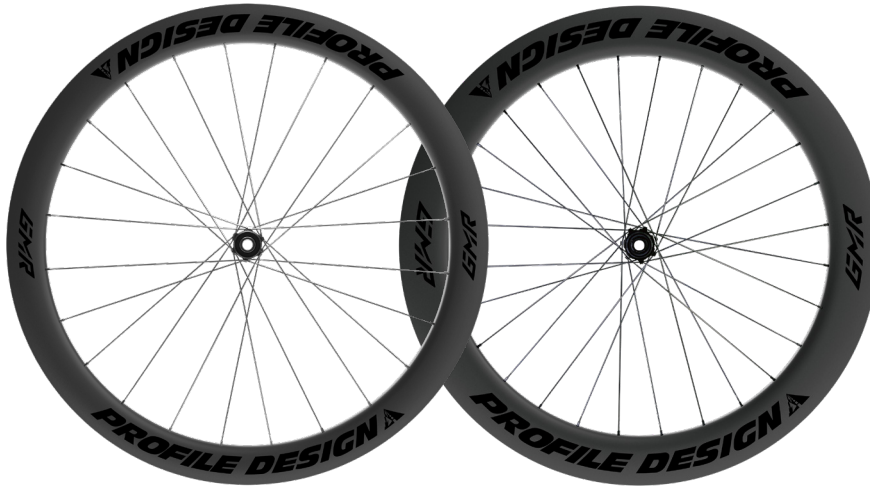

5026TL

6526TL

COMPONENT LIST

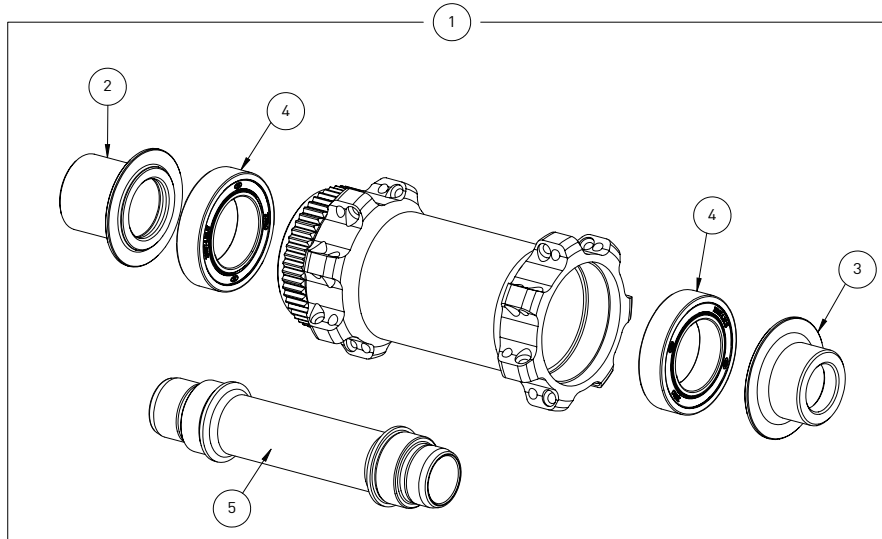

N	PN	Component	N	PN	Component
1	860188	Full Front Disc Hub	4	860172	Disc Front Hub Bearing
2	860173	Disc Side End Cap	5	860171	Disc Front Hub Axle
3	860174	Non-Disc Side End Cap			

COMPONENT LIST

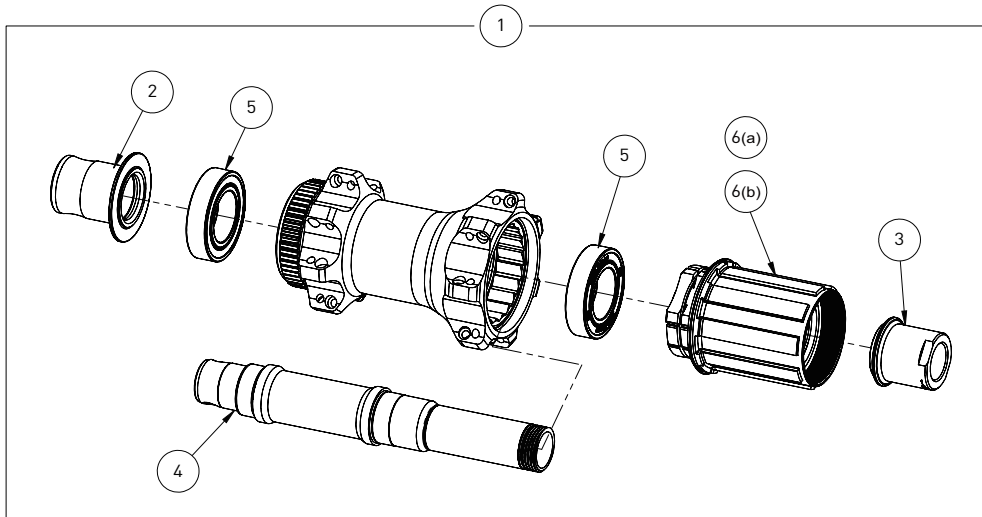

N	PN	Component	N	PN	Component
1	860189	Full Disc Rear Hub	5	860176	Disc Rear Hub Bearing
2	860178	Disc Side End Cap	6(a)	860181	10/11s Shimano / Sram Freehub
3	860179	Drive Side End Cap	6(b)	860183	SRAM 12s XDR Freehub
4	860177	Disc Rear Hub Axle			

SPOKE LENGTH

Wheel		Spoke Length
3826TL	Front disc side	283mm
	Front non-disc side	282mm
	Rear drive side	287mm
	Rear non-drive side	288mm

Wheel		Spoke Length
5026TL	Front disc side	270mm
	Front non-disc side	272mm
	Rear drive side	275mm
	Rear non-drive side	276mm

Wheel		Spoke Length
506526TL	Front disc side	270mm
	Front non-disc side	272mm
	Rear drive side	259mm
	Rear non-drive side	260mm

PRODUCT SPECIFIC SETUP LIMITATIONS

Only clincher or tubeless clincher tires can be used with these wheels.
 Only Centerlock mount rotors can be used with these wheels.

Recommended Tire Size	700C x 28-38mm
Recommended Inflation pressure (also refer to Tire sidewall)	70-100 PSI
Recommended Use	Road/Triathlon/Time Trial

INSTALLATION INSTRUCTIONS

Install Rim Strip(s)

1. Ensure that the rim bed is clean and free of debris.
2. Stick the end of the rim strip to the rim to one side of the valve.
3. Carefully stretch the rim strip around the rim.
 - a. go past the valve first.
 - b. make sure that the strip is centred on the rim and is covering the spoke holes.
 - c. Overlap the tape past the valve hole before cutting and sticking down the end.
4. You may choose to use a hair dryer to shrink the tape to remove wrinkles and ensure the tape is adhered to the rim. CAUTION if doing this – spread the heat evenly and avoid overheating the rim.
5. Use a pick or other sharp tool to create a hole for the valve in the rim strip.
6. **DO NOT** use tape or glue to secure the rim strip.
7. **DO NOT** use a thick fabric/cloth rim tape as this could prevent proper seating of the tire on the rim.

Installing Clincher Tires

1. Place the wheel, valve hole up, with the wheel resting against your legs and mount one side of the tire bead onto the rim using your hands.
2. Take note if your tire has directional arrows and also install the tire with the manufacturer's label/PSI rating at the valve hole – this will assist with finding flats and will make for easier inflation reference later.
3. Work the tire onto the rim by moving your hands away from the valve hole on each side of the wheel as you seat the tire bead.
4. If the last section of tire bead will not seat by hand VERY CAREFULLY use a PLASTIC tire lever to seat the last section of tire onto the wheel.
5. Inflate the inner tube enough that it will hold its shape.
6. Insert the valve of the tube through the valve hole of the rim making sure the valve is straight.
7. Then install the rest of the tube between the rim and tire. Make sure that the tube is not folded, twisted or creased once placed inside the tire.
8. Tubes are also sold in different diameters and widths. Make sure the tube size is closely matched with the tire size you are using. Use of the wrong size tube could lead to bunching or stretching of the tube and a blow out resulting in a crash and injuries.

9. Install the second bead of the tire onto the rim working the tire onto the rim by moving your hands away from the valve hole on each side of the wheel as you seat the tire bead.
10. If the last section of tire bead will not seat by hand VERY CAREFULLY use a PLASTIC tire lever to seat the last section of tire onto the wheel. Be careful that you do not pinch the inner tube with the tire lever or tire bead as you seat this last section. Make sure the tube is not under the bead of the tire anywhere on either side as this will burst the tube once you inflate it.
11. Inflate the tire to 40-60 PSI and check to make sure the tire is seated correctly and that the inner tube is not pinched between the tire and the rim. Deflate the tube and re-install the tire should there be any problems.
12. Inflate the tire to full pressure and check the tire as it is rotating to make sure the tire is seated straight on the rim. Also check the bead line (usually a small rib on the tire just a few millimetres above the rim edge) of the tire to insure that the bead is seated evenly and uniformly all the way around the rim on both sides.
13. **DO NOT EXCEED 125 PSI** for **ANY** Profile Design clincher rim regardless of the pressure listed on the tire.

INSTALLING TUBELESS TIRES

1. Push the tubeless valve through the rim strip and rim. Ensure it is fully seated then install the locknut.
2. Place the wheel with the wheel resting against your legs and mount one side of the tire bead onto the rim using your hands.
3. Take note whether your tire has directional arrows and also install the tire with the manufacturer's label/PSI rating at the valve – this will make for easier inflation reference later.
4. Work the tire onto the rim by moving your hands away from the valve on each side of the wheel as you seat the tire bead.
5. If the last section of tire bead will not seat by hand **VERY CAREFULLY** use a PLASTIC tire lever to seat the last section of tire onto the wheel.
6. Install the second bead of the tire onto the rim working the tire onto the rim by moving your hands away from the valve hole on each side of the wheel as you seat the tire bead.
7. If the last section of tire bead will not seat by hand **VERY CAREFULLY** use a PLASTIC tire lever to seat the last section of tire onto the wheel.
8. Inflate the tire to seat it, this may require going close to the maximum inflation pressure.
 - a. If using a standard floor pump you will need to pump vigorously to force the tire to expand and beads to seat. This method may not work with all tire models.
 - b. If using a chamber equipped pump, charge the chamber then release to give the tire an immediate blast of air.
 - c. If using an air compressor carefully give the tire a series of air blasts to avoid over-inflating.
9. Inflate the tire to full pressure and check the tire as it is rotating to make sure the tire is seated straight on the rim. Also check the bead line (usually a small rib on the tire just a few millimetres above the rim edge) of the tire to insure that the bead is seated evenly and uniformly all the way around the rim on both sides.
10. **DO NOT EXCEED 125 PSI** for **ANY** Profile Design clincher rim regardless of the pressure listed on the tire.
11. If the tire does not seat you may need to add another layer of rim strip or a thinner strip like electrical tape. Note that increasing the thickness of the rim strip will make mounting and removing tires more difficult.
12. Once you have confirmed that the tire is fully seated, deflate it and remove the valve core.
13. Fill the sealant injector with sealant and attach to the valve.
14. Inject the sealant to the volume recommended by the sealant manufacturer.
15. Remove the injector and wipe down the valve and rim if there has been any spillage.
16. Reinsert the valve core.
17. Inflate the tire to your target pressure.
18. Holding the wheel by the hub, spin the wheel and turn it to each side to ensure an even coating of sealant around the tire and rim.
19. Place the wheel down sideways for a few minutes, then flip over. This helps to ensure that the bead seat is covered.
20. After leaving the wheel for at least half an hour, check the pressure to determine whether there has been any air loss.
 - a. If no, it is ready to ride.
 - b. If yes, re-inflate and leave to sit. Check again later to determine whether the gaps have now sealed. If not, you may need to add more sealant.
21. Follow the sealant manufacturers instructions for advice on how often you should check or replenish the sealant.

FIT THE CASSETTE

1. Make sure you have the correct cassette for your free hub, speed and manufacturer.
2. Slide the Cassette on to the freehub.
 - a. If using a 10 speed cassette, first install the supplied 1.65mm spacer.
 - b. The spacer is not required for 11 speed cassettes.
3. Thread on the lockring by hand to ensure proper thread engagement.
4. Using a torque wrench, tighten the lockring to 50Nm (check Torque).

FIT THE DISC ROTORS

1. Line up the splines of the hub with those on the rotor and slide on the rotor, ensure that it is oriented as per the manufacturers instructions.
2. Fit the lockring and use the cassette tool (or manufacturer specific tool) to tighten to the manufacturer recommended torque level.

FIT WHEELS TO BIKE

1. Ensure the brake calipers are open.
2. Carefully line up the rotor with the disc brake caliper and slide the wheel into the dropouts.
3. Install the Through-Axle that was supplied with the bike and tighten to the manufacturer specification.
4. Spin the wheel to check that it is centred in the brake calipers and there is no rub.
5. Pull on the brakes to ensure there is sufficient force –the end of the brake lever should travel 20-30mm (1”) before contacting the rotor.

WHEEL MAINTENANCE

TRUING WHEELS

1. TRUING YOUR WHEELS ALL REPAIRS OR TRUING SHOULD BE PERFORMED BY A PROFESSIONAL BICYCLE WHEEL MECHANIC.
2. The technique and skill required to properly true a wheel is well beyond the scope of these instructions and beyond the ability of most riders.
3. Your wheels have been carefully pre-stressed, tensioned and trued before shipping and should remain true and round under normal riding conditions.
4. Ensure that your wheels do not have a vertical “hop” or side to side “wobble” once you remove them from the box (by spinning them in your dropouts without tires). They may have been damaged in shipping. Over time or under abnormal riding conditions you may need to re-true and re-tension your wheels for optimal performance. (Typically wheel truing needs to be done after 1000-2000 miles of riding).
5. If you are not sure how to properly perform this service or do not have a spoke tensiometer or wheel truing stand with run out gauges, please take your wheel to a professional bicycle mechanic, or contact Profile Design at www.Profile-Design.com for more details.

CLEANING YOUR WHEELS

1. Remove and clean the through-axles regularly and check they are firmly fastened
2. Avoid contaminating the brake rotors with grease or lubricant, clean using sand paper and brake cleaning fluid or Ethyl Alcohol
3. Also avoid contaminating the disc brake pads. If they require cleaning use sandpaper and brake cleaning fluid or Ethyl Alcohol. Avoid breathing the sanding dust.
4. Be sure to remove any dirt, grime, grit, grease or lubricant that might get onto the brake surface of the wheel.
5. Make sure your brake pads are clean and free from aluminum shavings, small rocks and other debris accumulated from riding.
6. Do not use harsh chemical cleaners on the rims, rotors or brake pads.

INSPECTING YOUR WHEELS

1. Cleaning or mounting a tire is a good time to inspect your wheels closely under good lighting conditions.
2. Look for any abnormal bumps or bulges, areas where the clearcoat is worn, any sign of frayed carbon fibers, cracks, deformities, or holes.
3. This inspection needs to be carried out on a regular basis but especially.
 - a. after any crash or after you have hit road debris or potholes.
 - b. when tires are removed.
 - c. before a race.
 - d. after shipping or flying with the bike .
 - e. when the tires have gone flat while riding.
 - f. when the wheels make any unusual noises such as clicking, squeaking, cracking or snapping noises.

TRAVELING WITH YOUR WHEELS

1. If you ship (or fly with) your bike and or wheels, the wheels should be transported in their own carrying cases to prevent damage.
2. We suggest heavily padded single wheel bags or a hard case.
3. After shipping or flying, the wheels must be inspected (see "Inspecting your wheels") and possibly re-trued (see "Truing your wheels") as flying or shipping wheels often will damage them or cause them to go out of true.
4. You may wish to remove the disc brake rotors for travel to avoid damage.

WARRANTY

- Profile Design Worldwide Two Year Limited Warranty.
- Profile Design, LLC (distributor) warrants to the original retail purchaser (“you”) that the Profile Design product for which you received this warranty is free from defects in material and workmanship for (2) two years from the date of original retail purchase.

For more details on this warranty, its exclusions and/or how to make a claim under the warranty please call +1 310.747.0085 extension 161 or visit www.profile-design.com/pages/warranty



2677 El Presidio Street

Long Beach, CA 90810

Ph: 310-884-7756

www.profile-design.com

© Profile Design LLC