



**PROFILE
DESIGN**

RZ3 DRINK BOTTLE CAGE

REVISION 02-04-17-2024

INTRODUCTION

Thank you for purchasing this Profile Design Drink Bottle Cage. These instructions apply to the RZ3.

Please read these instructions thoroughly before attempting to install this item. Proper installation is required for compliance with Profile Design's warranty policy. If you are not familiar with installation of bicycle accessories, please seek the assistance of your local Profile design dealer by logging on to www.profile-design.com and using "dealer search" or by calling Profile Design's customer service number p.# 888.800.5999.

Note to Dealers: If you install this product for the consumer, please provide him/her with this owner's manual after installation.

Tools and materials required:

- Grease such as Finishline Premium Grease
- Screwdriver

Your Drink Bottle Cage kit should contain:

- HSF 880 Bottle with top cap
- Straw with bite valve
- Aerodrink BTA bracket

If anything is missing from the bottle kit please contact your dealer.

WARNING: Periodically check the Cage for damage, particularly for cracks or scratches in the surface that could lead to degradation and weakening of the base material. Replace your AeroBar if you notice any damage from use or accident.

COMPONENT LIST

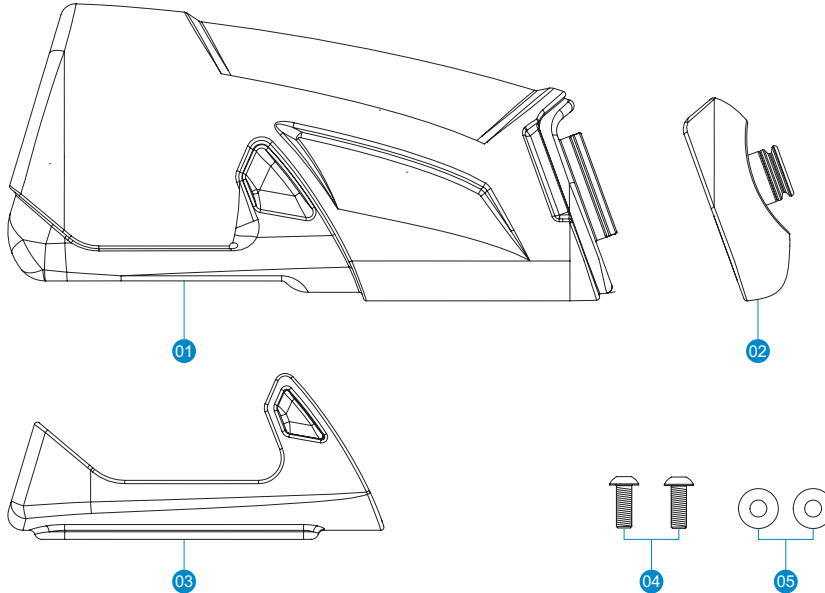

Ref.#	Part.#	QTY. Req.	Part Description
1	600216	1	Bottle - RZ3
2	B210	1	Cap - RZ3 with Bite Valve
3	414251	1	Cage
4	313598	2	Bolt - M5x14 BHB
5	275673	2	Washer

PART DRAWINGS

510ml (17.3oz)

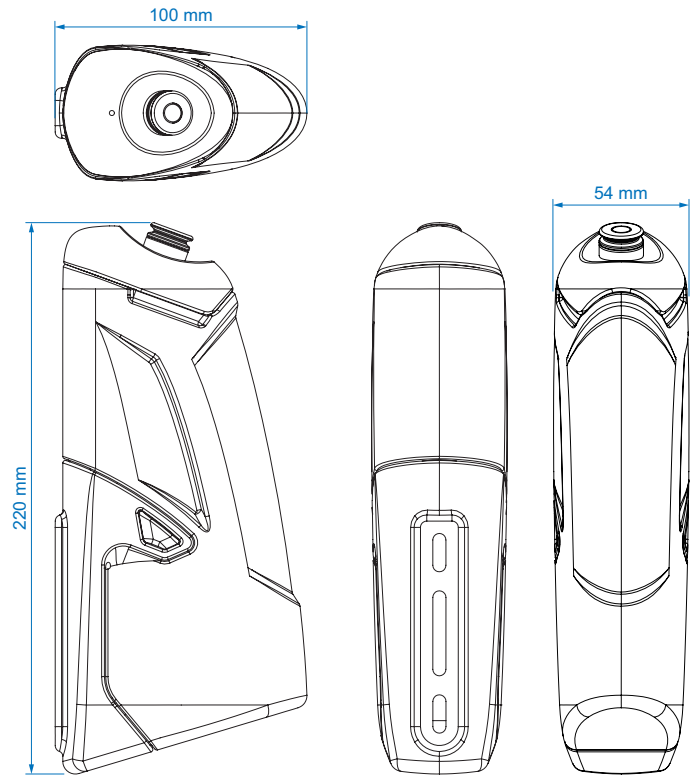

PRODUCT SPECIFIC SETUP LIMITATIONS

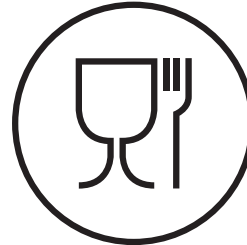
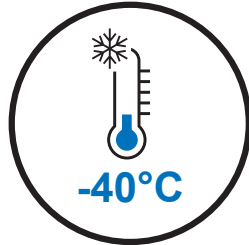
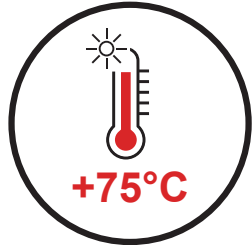

WARNING

If you want to put it in the dishwasher, please make sure that the temperature is maintained at a heat-resistant temperature. If not, we haven't recommended to put it in the dishwasher.

INSTALLATION INSTRUCTIONS

1. Make sure there are no any bolts or the hydration system in the bike frame. If yes, please help to remove them.
2. Apply grease to the M5x14 (2) bolts.
3. Use the bolts and washers to attach the cage to the frame.
4. Put the bottle in the cage.

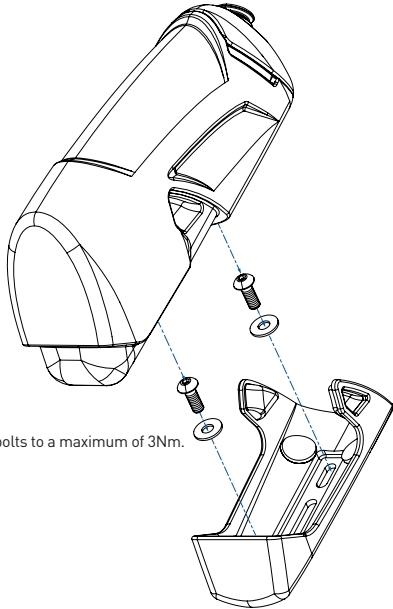

* Torque the bolts to a maximum of 3Nm.

HOW TO USE

Filling the bottle

1. Prase the cap off by inserting your fingers under the removal tab.
2. Fill the bottle with your choice of fluid.
3. Reinstall the cap by first lining up the bottle and cap, then pressing firmly.

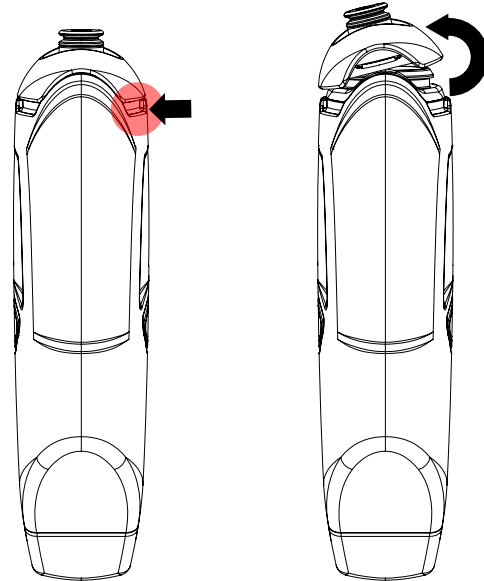

Using the bottle

1. When pulling the bottle from the cage twist it to one side first.

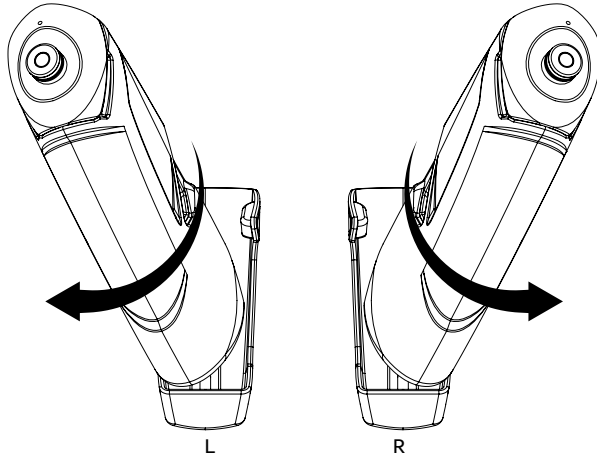

Warning: Pulling the bottle directly upwards risks cracking the cage.

2. To put the bottle back in the cage – first ensure the bottom corner is engaged, then push the bottle down into the clips.

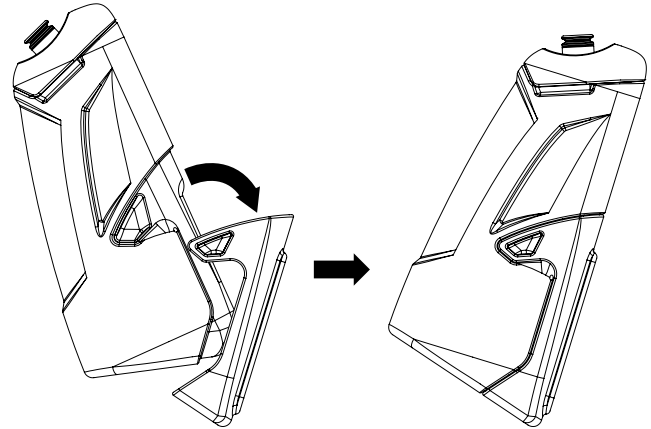

WARRANTY POLICY

- Profile Design Worldwide Two Year Limited Warranty.
- Profile Design, LLC (distributor) warrants to the original retail purchaser ("you") that the Profile Design product for which you received this warranty is free from defects in material and workmanship for (2) two years from the date of original retail purchase. For more details on this warranty, its exclusions and/or how to make a claim under the warranty please call +1 310.747.0085 extension 161 or visit www.profile-design.com/pages/warranty



2677 El Presidio Street
Long Beach, CA 90810
Ph: 310-884-7756

www.profile-design.com

© Profile Design LLC