



SAFESMART
ACCESS

Reaching new heights

ADAPTASPAN



NZ 0800 000 448 www.safesmartaccess.co.nz

ADAPTASPAN

There has been an increasing demand on construction and infrastructure projects worldwide to provide safer and user friendly egress ways for site personnel. SafeSmart Access are pleased to introduce an engineered aluminium modular bridging system.

This modular bridging system, has rapidly become a popular choice for projects that require an engineered, safe and cost effective access solution. AdaptaSpan bridge modules are available in 1m, 2m and 3m long sections, can be bolted/connected end-to-end to create large span walkways and bridges with spans up to 21m in length.

When looking for a temporary bridging system over excavations, creeks, trenches and to your tower crane, SafeSmart's AdaptaSpan bridging system is your answer:

SUMMARY OF BENEFITS

- AdaptaSpan system to provide safe access across trenches, canals, footpaths and work sites
- 1.2mW allows for two-way access
- Join modules together to create a clear span bridge up to 21mL
- Module sizes include; 1mL, 2mL and 3mL
- Crane bridge adaptations: Retro-fit pieces that can allow SmartSpan to connect to tower cranes.



ADAPTASPAN

Code	Description	Measurements
111003	Modular / Portable Site Access Bridge	1m module x 1.2mW, 2.5kPa
111006	Modular / Portable Site Access Bridge	2m module x 1.2mW, 2.5kPa
111004	Modular / Portable Site Access Bridge	3m module x 1.2mW, 2.5kPa
80160	Modular Bridge Anchor Bracket	-
111005	Modular Bridge Hinging End Ramp	0.7mL x 1.2mW
AESHLL	Modular Bridge Crane Lifting Lug	-
80671	AdaptaSpan Roller Bracket for General Access Bridge	1.2mW
80682	AdaptaSpan Hinging Bracket for General Access Bridge	1.2mW

CRANE BRIDGE ATTACHMENTS

Code	Description	Measurements
111014	Tower Crane Access Adapter Frame	0.6mL x 1.2mW
111021	Modular Bridge Tower Crane Access Entry/Exit Swing Gate with Mesh	2mH x 1.2mW
111037	Modular Bridge Tower Crane Access Anti-Climb Wings & Panel	2.5mH x 2.23mW

NEED TO GO LONGER? CREATE A SPAN UP TO 21M

Code	Description	Measurements
111040	Modular Bridge Accessories Brace structure incl H/ware	-
111041	Modular Bridge Accessories Guardrail Strongback	100x50x4mm RHS, 6.0mL with machined holes

Made in
NEW ZEALAND

Complies with
**AS/NZS
1657 : 2018**

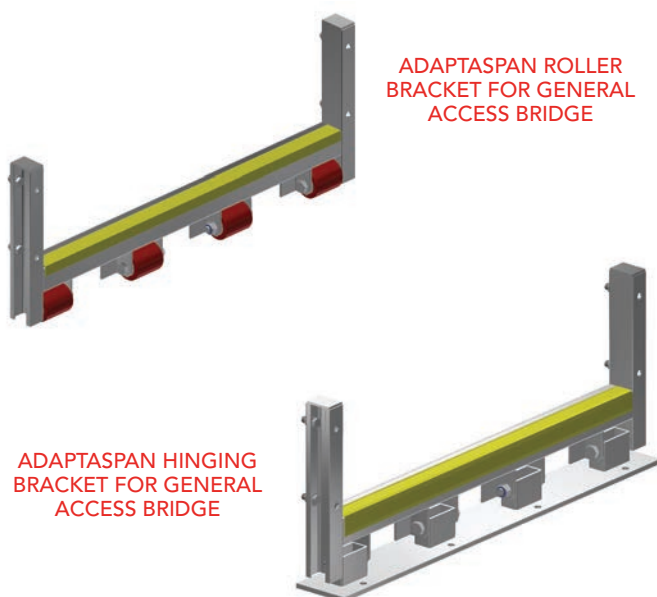

COMPONENTS

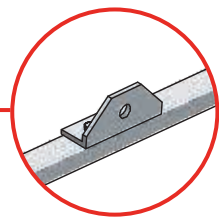
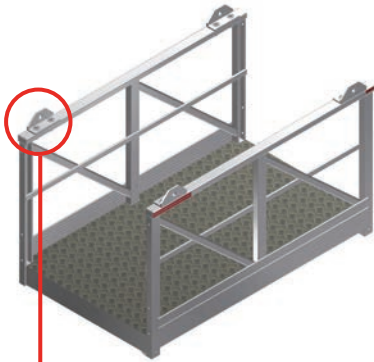

CRANE LIFTING LUGS

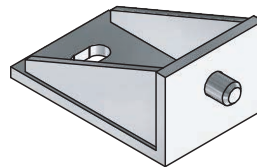

ANCHOR BRACKET

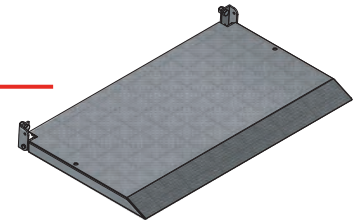
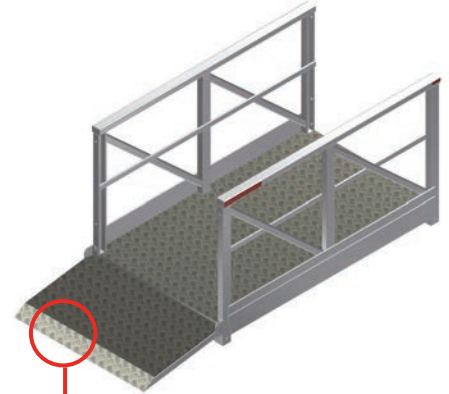

HINGING END RAMP

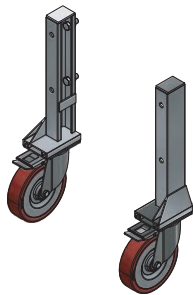
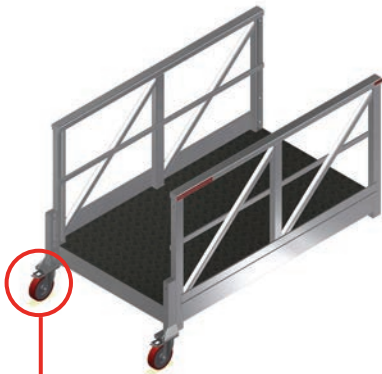

BOLT-ON CASTORS AND BRACKETS

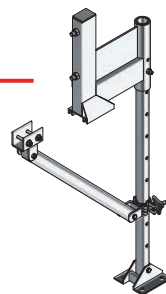
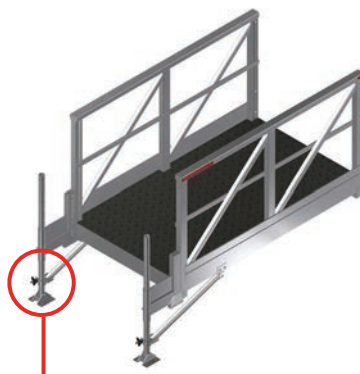

BOLT-ON HEIGHT ADJUSTABLE BRACKETS

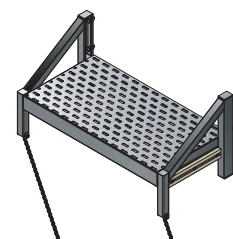
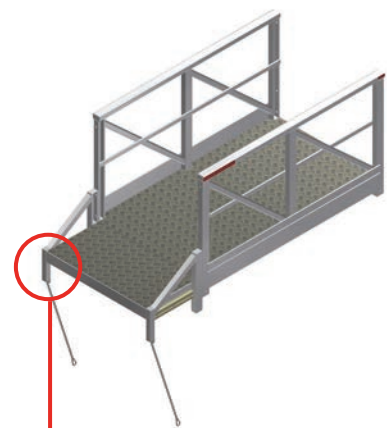

TOWER CRANE ACCESS ADAPTER FRAME

COMPONENTS

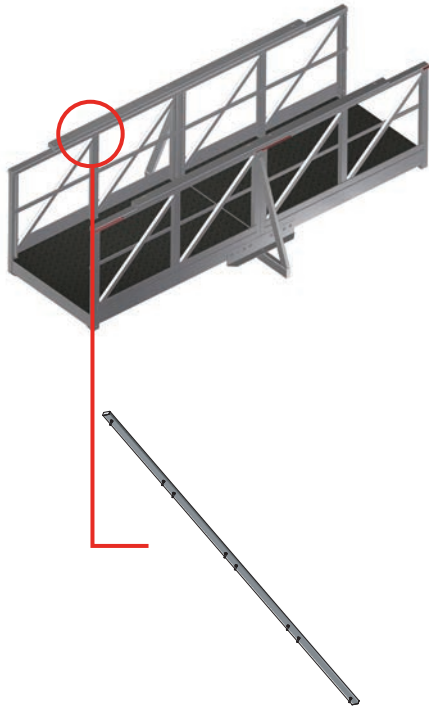

GUARDRAIL
STRONGBACK

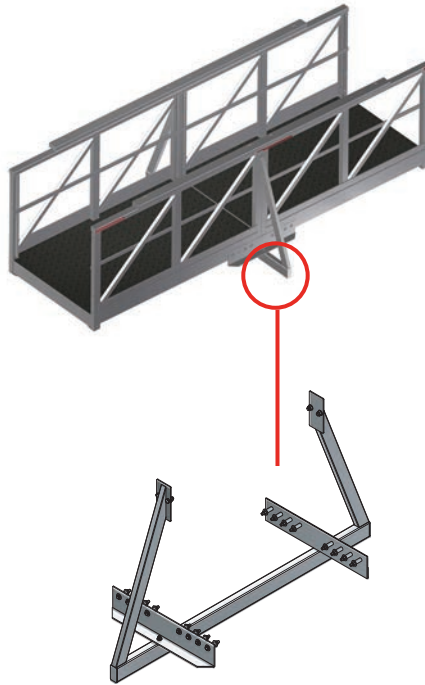

BRACE STRUCTURE
INC H/WARE

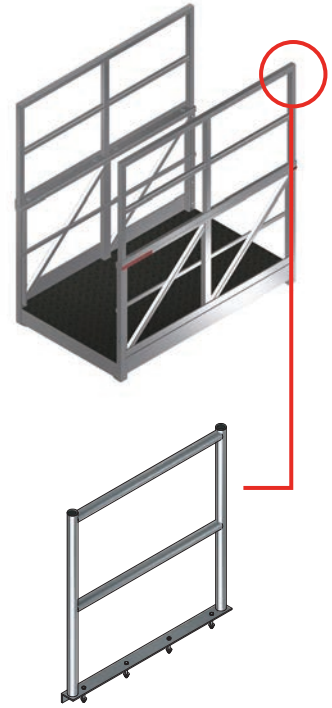

MODULAR BOLT-
ON EXTRA HEIGHT
GUARDRAIL PAIR

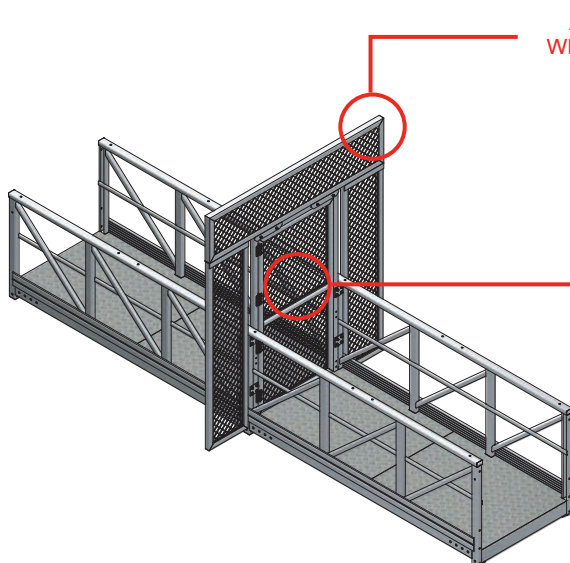

ANTI-CLIMB
WINGS & PANEL

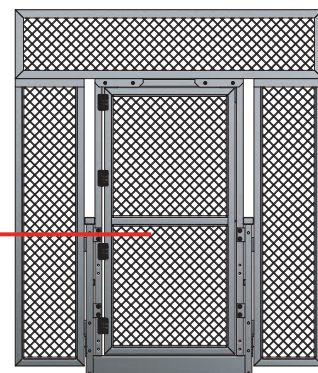

ENTRY/EXIT SWING GATE WITH MESH

CRANE BRIDGE

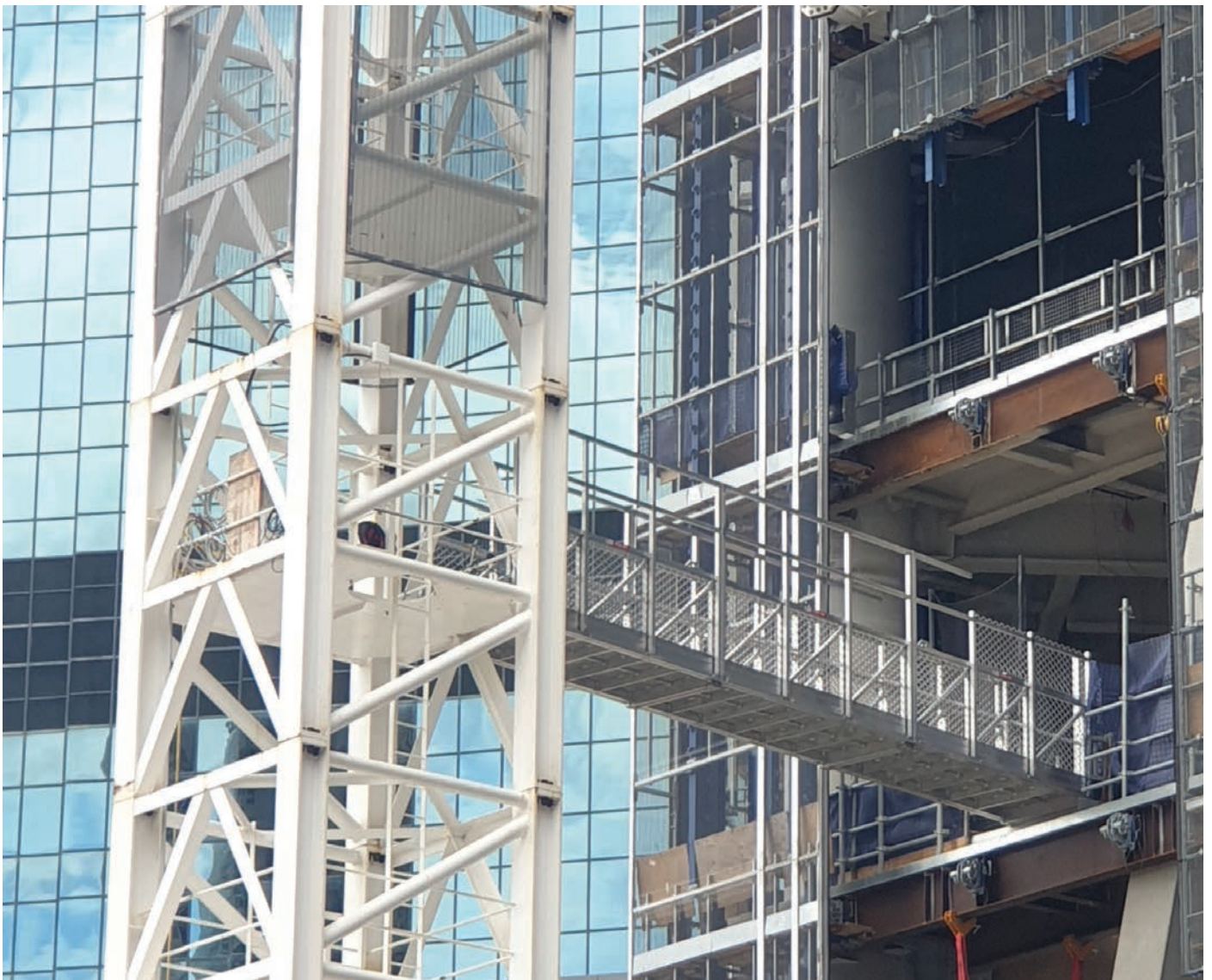

OTHER APPLICATIONS





NZ 0800 000 448

www.safesmartaccess.co.nz