

Jamb Detail

Drawing A
Side View

GW Installation Masonry Opening

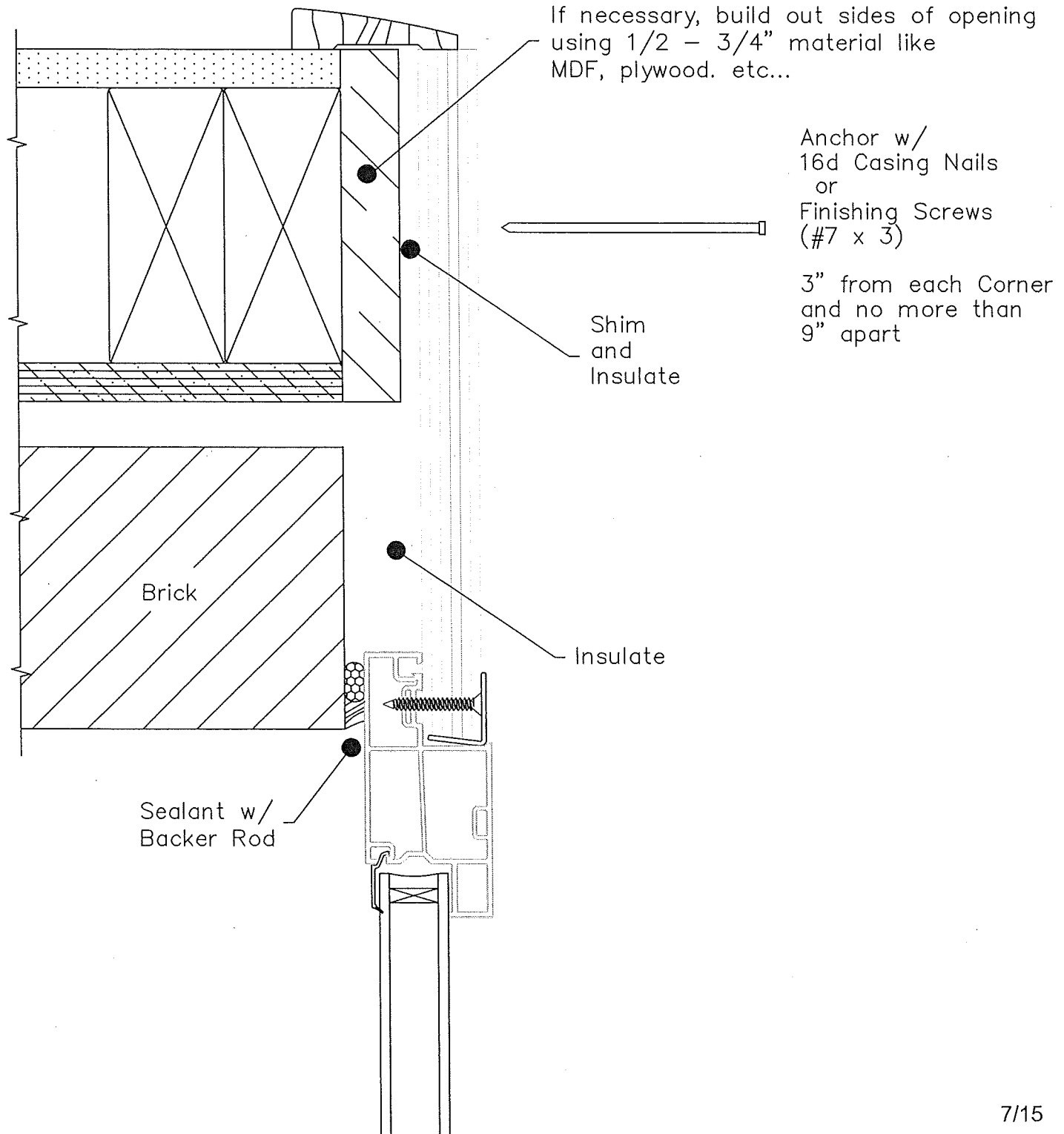

Head Detail

GW Installation Masonry Opening

Drawing B Top View

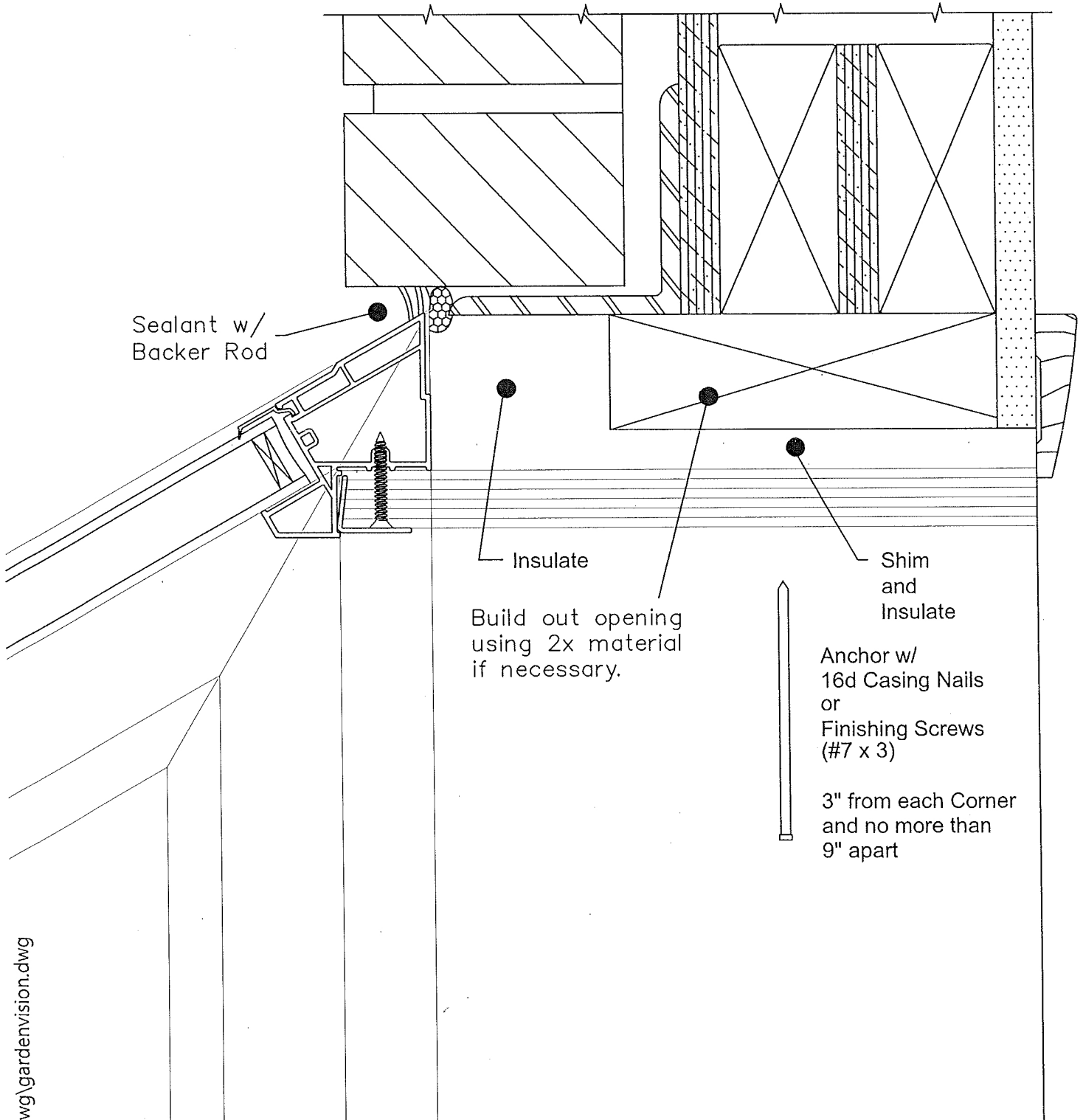

Seat Detail

Drawing C Bottom View

GW Installation

After Head and Jambs have been Secured, Drill through foam at angle through plywood. (6" from corners and no more than 12" apart)

Drive and set Casing Nails or finishing screws into plywood

Apply Casing

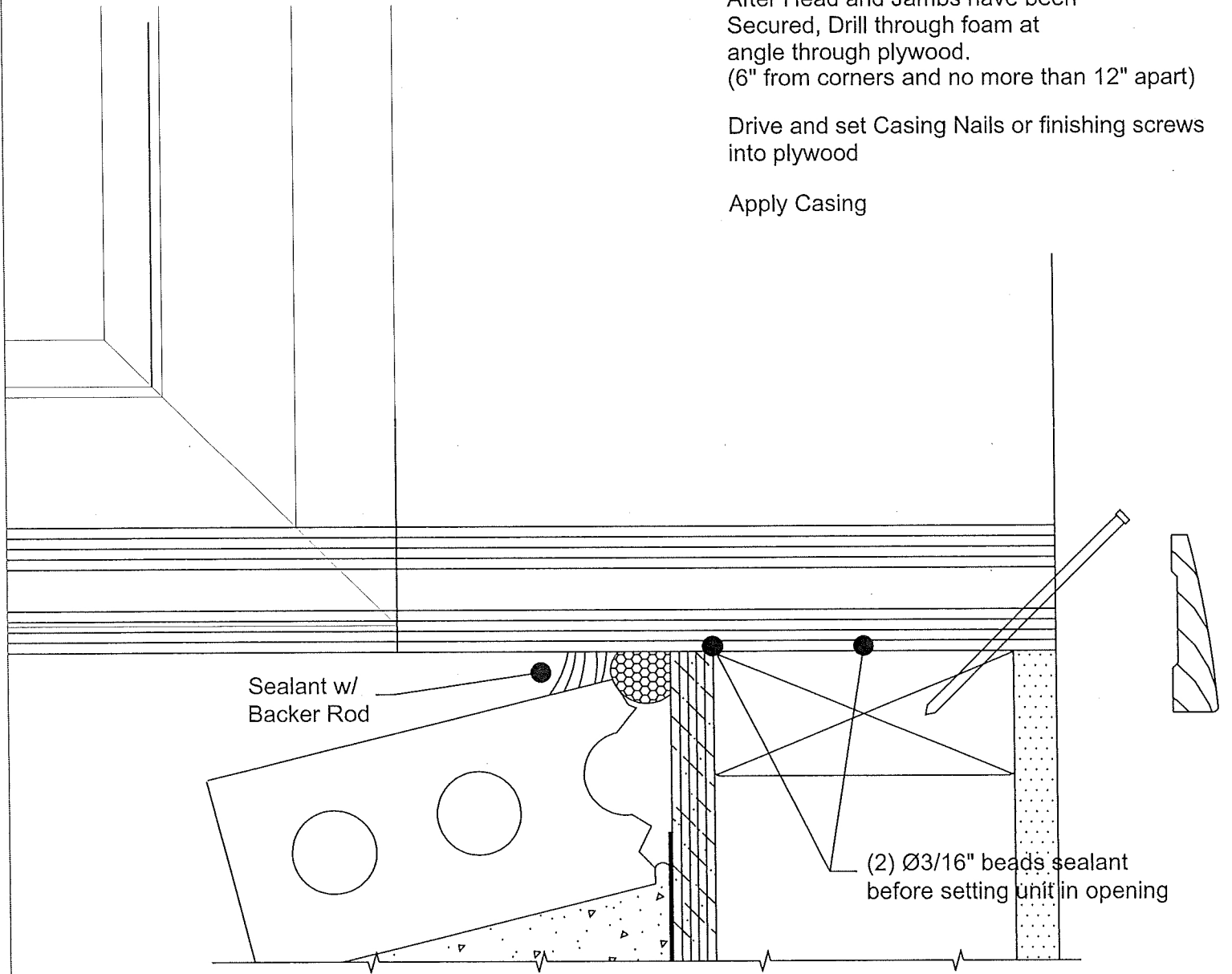

Max Load: 8 lbs SqFt Seatboard
8 lbs SqFt Shelf