

EXTRALINK

EXTRALINK

EXTRALINK 9U 600X600 AZH BLACK | RACK CABINET | WALL-MOUNTED, TWO-SECTION



OVERVIEW

The Extralink rack cabinet is designed for wall mounting in offices, network server rooms and CCTV installation control rooms. The outer walls are made of cold-rolled steel sheet. Equipped with a tempered glass pane, the front door can open to the left or right side. The two-section design of the cabinet facilitates rear access to the installed components.



THE HEIGHT OF THE CABINET IS CLEARLY MARKED

The vertical rails are marked with the appropriate height, which is 9U (unit), while the total height of the cabinet is 50.5 cm .



EASY DISASSEMBLY OF SIDE WALLS

Snaps on the side walls allow their removal. Locks and keys are included .



THE CEILING OF THE CABINET WITH THE POSSIBILITY OF INSTALLING FANS

There are 2 places to install fans on the ceiling of the cabinet for better cooling of devices, there are also 2 additional grommets for pulling cables.



DIMENSIONS

W - width 600mm

D - depth 600mm

H - mounting height 9U - 400.05mm

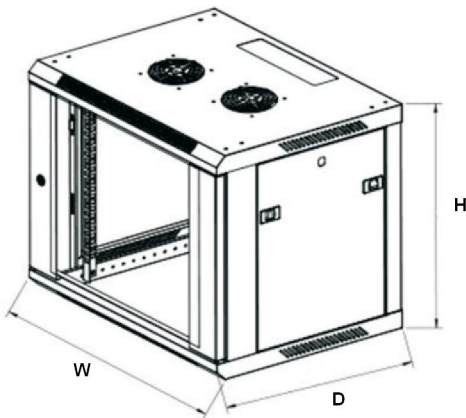

COMPONENTS

A - Bottom panel

B - Rear panel

C - Side panels, removable

D - Top cover

E - Cable hole

F - Frame

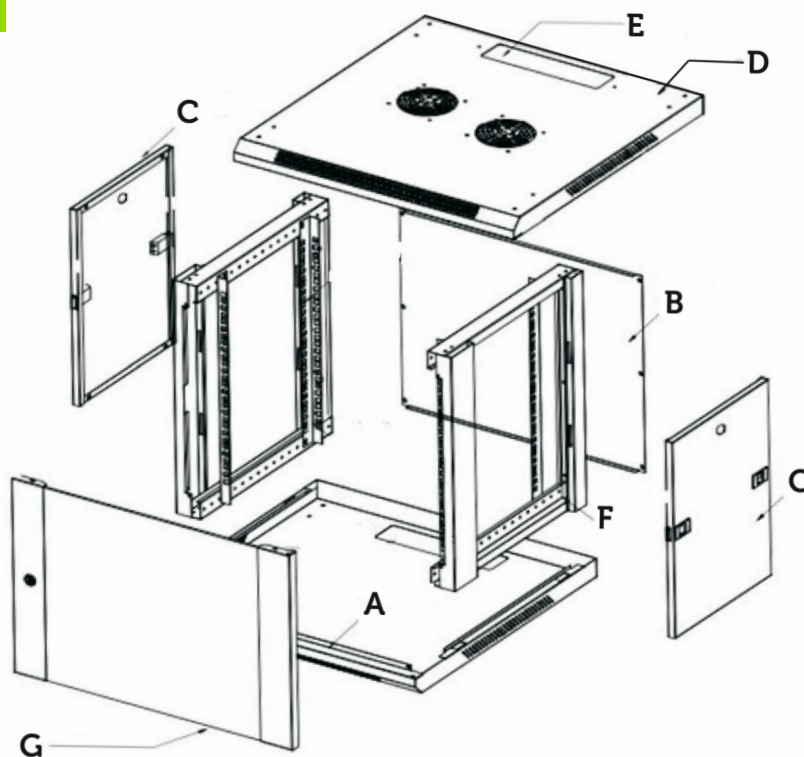



MAIN FEATURES

- Standard 19 " assembly, welded frame, reliable construction
- DIY frame structure - easy to carry and transport, which lowers shipping costs
- Wall or standing mounting
- Easy assembly (patent)
- Removable side panels
- Cable entry holes on both the top cover and bottom panel
- Tempered glass front door with a rotation angle of more than 180 degrees
- Two-section construction

SPECIFICATION

Cabinet type	Hanging two-section
Cabinet height	9U
Depth	600mm
Colour	Black
Type of door	Glazed
Width	600mm