



# Sewing by Sarah

52 PIECE  
PRESSER SET  
USER GUIDE



# Sewing Machine Presser Foot Set - User Guide

## CONTENTS

<b>I. What is in the box?</b>	<b>2</b>
<b>II. How to change the foot on a low shank sewing machine</b>	<b>3</b>
<b>III. Description of the different feet</b>	<b>4</b>
Fringe Foot or Looper Foot (1)	4
Double Welting Foot or Piping Foot (2)	4
Braiding Foot or Couching Foot or Cording Foot (3)	5
Pearl Piping Foot/Beading Foot (4 & 44)	7
7/5-Groove Pintuck Foot (5 & 6)	7
Invisible Zipper Foot (7, 38 & 39)	8
5/7 Hole Cording Foot (8 & 19)	8
Round Rolled Hem Foot (Rolled Hemmer) and Rolled Hem Foot (Narrow Hemmer) (9, 24, 25 & 26)	9
Zigzag Foot (10)	9
Open Toe Embroidery Foot (11)	10
Large Opening Presser Foot (12, 45 & 47)	10
Cording Foot (13)	10
1/4 " Quilting Foot (14)	11
Straight Stitch Foot (15)	11
1/4 " Quilting Foot with guide (16)	11
Overcast Foot (17 & 48)	12
Satin Stitch Foot (18)	12
Edge Joining Foot or Stitch-in-the-Ditch Foot (20)	13
Stitch Guide Foot (21)	13
Blind Stitch Foot/Blind Hem Foot (22 & 40)	14
Shirring Foot/Gathering Foot (23)	14
Roller Foot (27)	15
Darning Foot 1 (28)	15
Adjustable Bias Binding Foot (29)	16
Free Motion Darning Foot (30, 41 & 42)	16
Adjustable Zipper Foot (31)	17
Knit Foot or Tricot Foot (32)	17
Button Sewing Foot (33)	18
Applique Foot (34)	18
Buttonholing Presser Foot (35)	18
Zipper Feet (36 & 37)	19
Low-Shank Adapter (43)	19
Ultimate Threader (46)	19
Universal Presser Feet (49 & 50)	20
Whipstich Presser Feet (51 & 52)	20



# Sewing Machine Presser Foot Set - User Guide

## I. What is in the box?



- |                              |                               |                              |                               |
|------------------------------|-------------------------------|------------------------------|-------------------------------|
| 1. Fringe Foot               | 14. 1/4" Quilting Foot        | 27. Roller Foot              | 40. Blind Stitch Foot (Steel) |
| 2. Double Welting Foot       | 15. Straight Stitch Foot      | 28. Darning Foot             | 41. Free Motion Foot (Open)   |
| 3. Braiding Foot             | 16. 1/4" Quilting Foot        | 29. Bias Binder Foot         | 42. Free Motion Foot (Closed) |
| 4. Pearl Piping Foot         | 17. Overcast Foot             | 30. Darning Foot             | 43. Low-Shank Snap Adapter    |
| 5. 7-Groove Pintuck F.       | 18. Satin Stitch Foot         | 31. Zipper Foot (LS)         | 44. Beading Presser Foot      |
| 6. 9-Groove Pintuck F.       | 19. 7-Hole Cording Foot       | 32. Knit Foot                | 45. Open Toe Foot             |
| 7. Invisible Zipper Foot     | 20. Edge Joining Foot         | 33. Button Pressing Foot     | 46. Ultimate Threader Tool    |
| 8. 5-Hole Cording Foot       | 21. Stitch Guide Foot         | 34. Applique Foot            | 47. Open Toe Foot with guide  |
| 9. 6mm Round Rolled Hem Foot | 22. Blind Stitch Foot         | 35. Buttonholing Foot        | 48. Overcast Foot (Slim)      |
| 10. Zig Zag Foot             | 23. Shirring Foot             | 36. Zipper Foot (Med)        | 49. Universal Presser Foot 1  |
| 11. Open Toe Embroid. F.     | 24. 3mm Rolled Hem Foot       | 37. Zipper Foot (Small)      | 50. Universal Presser Foot 2  |
| 12. Large Opening Foot       | 25. 6mm Rolled Hem Foot       | 38. Zipper Foot (Large)      | 51. Whipstitch Foot 1         |
| 13. (3-Hole) Cording Ft.     | 26. 3mm Round Rolled Hem Foot | 39. Inv. Zip. Foot (Plastic) | 52. Whipstitch Foot 2         |



## Sewing Machine Presser Foot Set - User Guide

### II. How to change the foot on a low shank sewing machine

**VIDEO DEMO:** [Changing Your Sewing Machine Feet](#) (click to view)

Removing a presser foot:

Raise the needle and the presser foot lever.

The way to remove the presser foot depends on the brand of machine you have. Sometimes it just snaps off, but with most machines you have to push a button or lever on the presser foot holder. Consult your machine's user manual to find the way to remove the presser foot.

Attaching a presser foot:

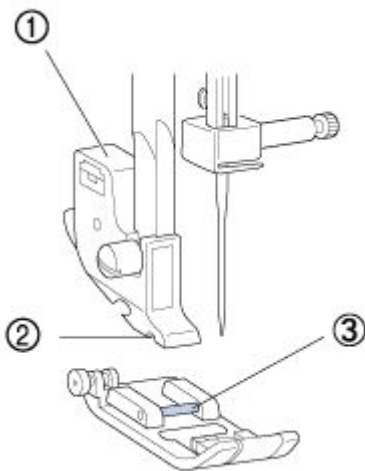

Lower the presser foot lever so that the presser foot pin (3) snaps into the shank (2) in the presser foot holder (1). You may have to try a couple of times before it snaps in. If your presser foot holder has a lever or button for release, it may be necessary to pull/press it to facilitate snap-on. The presser foot holder can look different on your machine, this picture is from a Brother sewing machine.



## Sewing Machine Presser Foot Set - User Guide

### III. Description of the different feet

#### Fringe Foot or Looper Foot (1)

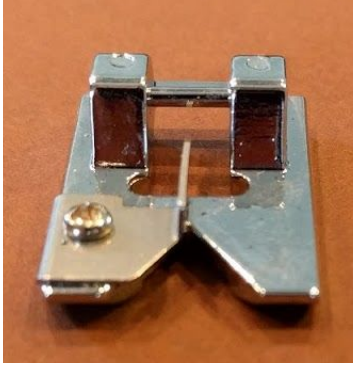

A simple to use foot to produce a couple of stunning embellishments for your sewing projects. Fringes, chenilles and loops can be used to great effect on cushions, clothes, quilts, bags, toys and more.

Use a zigzag or ladder stitch and stitch length depending on the effect you want (0.7 is a good starting point to experiment with).

Notice in the center of the foot there is a raised metal piece that looks like an upside down ice skate. Don't worry, it's not sharp. It just "looks" like an ice skate. This center bar is what the thread stitches over to create the fringe which is really just large loops. The wider the zigzag or ladder stitch used, the longer the fringe loops will become.

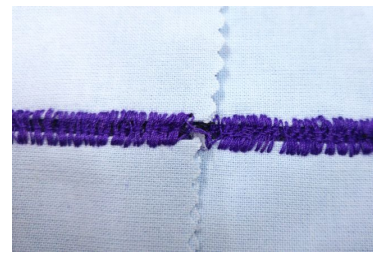

**VIDEO DEMO:** [How To Use a Fringe Foot](#) (click link to view)

**BLOG POST:** [4 Fun Ways to Use a Fringe Sewing Foot](#) (click link to view)

#### Double Welting Foot or Piping Foot (2)



Use this foot to couch single or double rows of cording to your fabric. It can also be used to make single and double rows of piping. Underside of foot has two grooves to accommodate the cording. The double rows of piping, also known as double welting cord, are often found as a finishing trim in home décor.

Maximum stitch width of 4 mm and cord size between 4 and 6 mm (between 1/8" and 1/4").





## Sewing Machine Presser Foot Set - User Guide

### Instructions



1. Select a straight stitch.
2. Cut a strip of bias fabric approximately 4" wide. The fabric needs to be wide enough to cover the cording(s) being used plus 1 ¼" (for standard 5/8" seam allowances) excess can be trimmed off.
3. Fold the bias strip in half, placing the cord in the fold. Align the fabric covered cord under the foot and sew along the cord edge.
4. Add a second cord between the fabric layers. Move the cord under the first groove (or groove on right) in foot, and stitch along the edge of the cord.
5. Trim the excess fabric to an even width down the length of the cord.

### Braiding Foot or Couching Foot or Cording Foot (3)



The braiding foot is one of many types of feet used in couching, which is a form of decorative embellishment, where a length of braid, cord, piping, ribbon, thread, trim or yarn is couched or stitched over to attach it to a fabric project. Through [Sewing By Sarah](#), you might discover a wealth of new techniques or styles ;-).

The foot has a hole in the top of the foot, allowing the braid to be threaded from the top of the foot and passed under the foot. The foot is adjustable for the size of the braid, having an adjustable guide that is moved to accommodate the width of the braid by loosening a screw and moving the guide.

The type of stitch used is usually a straight stitch, zigzag or decorative stitch depending upon the type of embellishment that is being sewn. Braid is generally sewn to the fabric with a stitch right down the center of the braid. A [Sewing by Sarah](#) favorite.

**VIDEO DEMO:** [Add dimension with the braiding foot](#) (click to view)

### General instructions



1. Select a straight stitch or a zigzag stitch. Most of the time you will want to use a zigzag stitch.
2. Place the width of the zigzag just wide enough to clear the braid, cord, or elastic that you are using.
3. Loosen the screw on the left of the foot to allow you to move the adjustable plate forward and back to accommodate varying widths of braid, cord, or elastic.
4. Snug the plate close to the braid that you are applying to help guide the braid. Let the braid feed in as you guide the fabric on the transferred design.



## Sewing Machine Presser Foot Set - User Guide

### Instructions for couching elastic



1. Thread the elastic through the hole on the braiding foot from the top and under the back of the foot. Move the guide by loosening the screw and snugging it up to the elastic but allowing the elastic to slide through freely.
2. Select the overcast stitch, adjusting the width to cover the elastic.
3. Begin sewing letting the elastic slide through the foot as you sew.
4. Pull the elastic up to the degree of gathers as desired. the elastic should slide easily in the thread casing.

### Instructions for gathering with elastic



1. Mark the placement of the elastic.
2. Feed the elastic through the hole on the front of the foot and under the back. Slide the metal guide around the elastic and tighten the screw. The elastic should be able to slide easily through the hole.
3. Select the appropriate tape attaching stitch on your machine. Lower the needle and take a few stitches to hold the elastic in place.
4. As you start sewing, stretch the elastic in front of the foot. The fabric will begin to gather behind.

### Instructions for trims with twin needles



1. Position the ribbon or trim in the spot desired. Select the twin needle width desired.
2. Thread the ribbon or trim through the braiding foot and tighten the screw.



# Sewing Machine Presser Foot Set - User Guide

## [Instructions for passementerie](#)



1. Draw your design on your fabric first.
2. Back the fabric with tear-away stabilizer.
3. Thread the soutache cord through the hole on the front of the foot and under the back. Move the metal slide close around the trim.
4. Lower the needle into the center of the trim and begin sewing.
5. As you sew curves, do not pull the trim too tight as you sew.
6. Be sure to keep the needle in the center of the trim. Use your presser foot lifter to pivot as you sew.

## Pearl Piping Foot/Beading Foot (4 & 44)



At [Sewing By Sarah](#), we love this one.

This foot has many uses such as sewing seams in knitwear, attaching beads up to 4mm, and making and applying piping up to 1/4" in diameter. Also sews corded pin tucks, sews piping 1/8", 1/4" & 3/8" (for piping your machine must have a left or right needle position). To attach beads, select a zigzag wide enough to clear the beads. The width of the zigzag should be set the same as the diameter of the beads. Use a matching or monofilament thread to hold the beads to our work. We recommend reducing the pressure on the presser foot to keep the beads from dragging and creating puckers in the fabric.

## 7/5-Groove Pintuck Foot (5 & 6)



The Pintuck Foot creates even tucks and is easy to use. Simply install a Twin Needle, feed your fabric through the foot, and watch as perfect pintucks form instantly. A Pintuck Foot can be used with or without cording. Thin cording (1/16) creates a bold and defined pintuck. When using cording with your Pintuck Foot, it is best to use a cording guide plate cover. This ensures your cording is fed directly into the foot center. The number of grooves depends on the weight of your fabric. The heavier the fabric, the less grooves. The lighter the fabric, the more grooves. See the video's or the blog post for detailed explanation on how to use the pintuck feet.

**VIDEO DEMO:** [How to Use a Pintuck Foot](#)

**VIDEO DEMO:** [How To Use A Pin Tuck Foot with Cording](#)

**BLOG POST:** [How to Use the Pintuck Foot](#)





## Sewing Machine Presser Foot Set - User Guide

### Invisible Zipper Foot (7, 38 & 39)



This zipper foot makes inserting invisible zippers very easy. The grooves on the bottom of the foot hold the zipper coils in place to avoid any slipping while sewing. This provides an invisible closure on skirts, dresses and all garments and can be used on other projects as well.

What are the differences between the invisible and the standard zipper foot?

1. The invisible foot is used with the zipper open, and the right half of the zipper is placed under the right groove of the foot, the left half of the zipper is placed under the left groove of the foot.
2. The zipper is sewn to the garment before any other stitching is done to the seams
3. The zipper is actually sewn with right sides together, right side of zipper to the right side of the fabric, and it is the fabric that is turned to conceal with zipper, once the stitching is done.

The zipper is really considered invisible because there is no stitching showing on the right side of the fabric, because the fabric has been folded to the inside of the garment.

**VIDEO DEMO:** [How to sew in an Invisible Zipper using an invisible zipper foot](#)

**INFO PAGE:** [How to Sew an Invisible Zipper in 4 Simple Steps](#)

### 5/7 Hole Cording Foot (8 & 19)



Use this foot to attach decorative cords and threads. Select threads and small cords that will glide easily through the holes on the cording foot of your choice. Select the multi-step zigzag stitch and adjust it wide enough to catch the outside threads. Now that your threads are under control, you can place both hands on the fabric to guide and move through the pattern you select.

**VIDEO DEMO:** [How to use a 5 hole cording foot](#)

### What is cording?

Cording is the technique of binding or connecting an uncovered cord embellishment to a fabric. It is different from welting, which is covered cording, meaning that the cord is encased inside of fabric, then



## Sewing Machine Presser Foot Set - User Guide

attached to another fabric, usually for a heavy duty project, a pillow edge for example for a decorative effect.

Cording is also different from piping which is a lighter weight covered cord, placed inside of a seam or along a project edge as a trim on a garment. These are generally home décor techniques, but cording and piping can be used to decorate garments.

There are also piping and welting feet, which have grooves on the underside of the foot, and work in a similar manner, but works differently than multi-cording feet.

### Round Rolled Hem Foot (Rolled Hemmer) and Rolled Hem Foot (Narrow Hemmer) (9, 24, 25 & 26)



This foot is perfect for hems that are too small to sew by hand. It automatically curves under a 3 (1/8") or 6 mm (1/4") double hem while stitching with a straight stitch. This foot works best on blouses, gowns, and other projects with lightweight fabric.



The difference between the round rolled hem foot and the rolled hem foot is on the bottom side. The round rolled hem foot has a round groove that runs along the whole foot, the rolled hem foot has a short flat groove.

Diference in use are very clearly explained in the following article from Threads Maganzine: <http://www.threadsmagazine.com/item/3744/mastering-the-narrow-hemmer-part-one> . In the article the name for the round rolled hem foot is rolled hemmer. The name for the rolled hemmer is narrow hemmer. VIDEO DEMO: [How To Sew Rolled Hems with the Narrow Hemmer Foot](#)

### Zigzag Foot (10)



This foot is designed to prevent fabrics such as leather and vinyl / oil-cloth, plastic, suedes and ultrasuede from sticking to the bottom of the foot and to the foot plate of the sewing machine.

The shape of this foot is the same as your regular straight stitch/zigzag/all-purpose foot to suit any situation.



## Sewing Machine Presser Foot Set - User Guide

### Open Toe Embroidery Foot (11)



This foot provides an unobstructive view of your work while sewing since there is no bridge between the toes. In addition, there is a groove on the underside to allow dense decorative stitches to pass underneath without jamming. Both of these characteristics make this foot ideal for doing applique and other sewing techniques where precision sewing is important.

**VIDEO DEMO:** [How to sew using an Open Toe Embroidery Foot](#)

### Large Opening Presser Foot (12, 45 & 47)



Like the previous foot the large opening presser foot provides an unobstructive view of your work while sewing since there is no bridge between the toes. In addition, there is a groove on the underside to allow dense decorative stitches to pass underneath without jamming. Both of these characteristics make this foot ideal for doing applique and decorative stitching. Foot #46 has guide markings also.

### Cording Foot (13)



Use this foot to attach decorative cords and threads. Select threads and small cords that will glide easily through the holes on the cording foot of your choice. Select the multi-step zigzag stitch and adjust it wide enough to catch the outside threads. Now that your threads are under control, you can place both hands on the fabric to guide and move through the pattern you select.

**VIDEO DEMO:** [How To Use A Cording Foot](#)



## Sewing Machine Presser Foot Set - User Guide

### 1/4 " Quilting Foot (14)



This foot has markings so you can sew an exact 1/4" seam when piecing or create perfect 1/4" or 1/8" topstitching. This foot also features raised markings along the sides of the foot for easy and flawless pivoting.

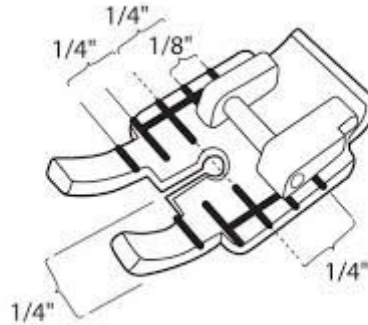

### Straight Stitch Foot (15)



This foot is especially useful on lightweight fabric and tackling multiple layers. It is designed to glide evenly over fabric so you avoid puckering. The built in measuring gauge on the right toe is great for accurate topstitching and the toes are a great edge stitching guide. The big left hand toe allows to easily tackle multiple layers of fabric.

### 1/4 " Quilting Foot with guide (16)



Similar to the 1/4" quilting foot but with a guide built in at the right side.

**BLOG POST:** [Quilting Foot or Patchwork Foot](#)

**VIDEO DEMO:** Included in the above blog post





## Sewing Machine Presser Foot Set - User Guide

### Overcast Foot (17 & 48)



This foot delivers a consistent and accurate overcasting stitch for a serged effect using your sewing machine. Thread is locked around the edge of fabric, aligned with the edge, to prevent fabric from raveling.

**VIDEO DEMO:** [How To Use an Overcast Foot](#)

### Satin Stitch Foot (18)



This foot is ideal for decorative sewing, such as applique, satin stitching and cut work. It has a grooved bottom, which allows for thread build-up and a wide needle hole opening to accommodate decorative stitches.

Use a satin stitch or a zigzag stitch with very low stitch length. You can use a stabilizer at the bottom to help the stitch be more secure. More information on stabilizers can be found [here](#).

**VIDEO DEMO:** [How to sew using a Satin Stitch Foot](#)



## Sewing Machine Presser Foot Set - User Guide

### Edge Joining Foot or Stitch-in-the-Ditch Foot (20)



The edge joining foot is used for edge stitching, stitch-in-the-ditch stitching and heirloom sewing. The center bar is the perfect guide for fabric edges. Unlike the blindhem foot where the bar extends into the needle hole, the edge joining foot's bar stops before the hole making it possible to use any stitch on your machine with this foot.

The marks on each side make aligning your fabrics and turning easier. The second mark on the left side lines up with the slight indentation on the right side of the foot. Use these marks to start sewing two lace edges or fabric and lace in the same place.

To begin sewing place the edge of the fabric, lace or trim against the left edge of the bar on the foot. Choose a straight or zigzag stitch that will catch the edge of the fabric or trim as well as sew into the background fabric.

**VIDEO DEMO:** [How to Use the Edge Joining Foot](#)

### Stitch Guide Foot (21)



This Presser Foot has a Ruler and can easily sew the precise equidistant parallel lines you want while topstitching.

Use it for projects that require accuracy, such as garments, topstitching or piecing while quilting.

The ruler allows to stitch precise seam allowances up to 1" wide and has a precision scale that goes up per 2mm.

When sewing a curve, keep the edge and the presser foot scale at right angles, In order to get a good curve effect.

**VIDEO DEMO:** [Stitch Guide Foot](#)



## Sewing Machine Presser Foot Set - User Guide

### Blind Stitch Foot/Blind Hem Foot (22 & 40)



Use this foot for precise stitch placement on blind-hems. The procedure for creating a blind hem with this presser foot is clearly explained in the video demo.

**VIDEO DEMO:** [How to Use a Blind Hem Foot](#)

**VIDEO DEMO:** [How To Blind Hem Trousers](#)

### Shirring Foot/Gathering Foot (23)

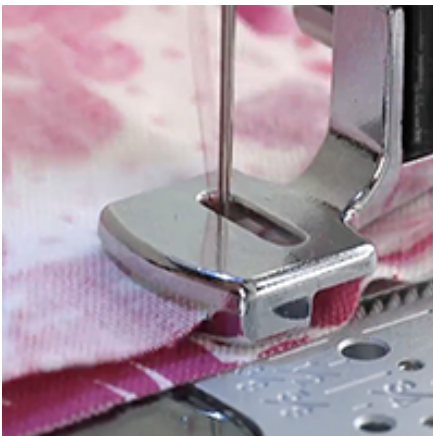

Fabric layers are placed under the foot and gathered automatically. Make ruffles for garments, pillows, or other home décor items.

A number of factors will affect the amount of fullness that is achieved:

- **Stitch length:** If adjusted to a longer stitch - more fullness. If the stitch length is shortened - less fullness.
- **Needle tension:** If needle tension is tightened: more fullness. If less tension: less fullness.
- **Fabric types:** If your fabric is light, such as batiste or lace, you will have more fullness. If the fabric is heavier, such as broadcloth or decorator fabrics, the fullness will be less.

If you look closely at your Gathering Foot - you will see a slot on the bottom. When using this slot, you can gather the bottom layer of fabric while attaching it to a flat top layer, such as on a waistband.

When testing your machine for adjustments to achieve desired fullness, work with 10" increments of fabric, trim or elastic. This makes it easier to determine the adjustments and how much change is needed for your project. Always test on your project fabric on the same grain line as you will be using in your finished project. Using the cross grain of the fabric will make prettier gathers than the straight of grain. For additional fullness, hold your finger behind the foot while sewing so the fabric gathers against your hand.

**VIDEO DEMO:** [How to Use a Gathering Foot](#)

**INFO PAGE:** [All About the Gathering Foot](#)



## Sewing Machine Presser Foot Set - User Guide

### Roller Foot (27)



The roller foot makes sewing difficult fabrics such as leather, suede and vinyl a breeze. This foot is a very clever little invention in the presser foot arsenal of the home sewer.

This foot is aptly named, and it is generally obvious to anyone looking at it what it is, unlike some presser feet, one can see what it is, but what does it do? This marvelous tool takes the frustration out of sewing slippery fabrics, which in addition to leather, suede, and vinyl, can include chiffon, organza and even velvet.

The foot has one large roller on the front of the foot and two smaller ones on the underside of the foot, which help to stabilize slippery fabrics. This

little jewel provides traction holding the fabric in place as the feed dogs feed the fabric through the machine, slippery fabrics thus don't move all over the place, or stick to the throat plate, but proceed in the direction that they are supposed to go in, forward through the machine.

**BLOG POST:** [Accessoires We Love: The Roller Foot For Velvet & More](#)

**VIDEO DEMO:** [How to sew using a Roller Foot](#)

### Darning Foot 1 (28)



The darning foot is a multi-purpose foot, not only is it used for embroidery, but it is also used for free motion quilting and of course darning, which is also just basic, old fashioned garment mending. This has a distinctive circular shape.

The foot is attached to the presser foot bar by removing the existing presser foot and shank and attaching the darning/embroidery/quilting foot, which has its own shank. With this foot the feed dogs must also be either dropped or covered.

For embroidery and darning the fabric project should be hooped for stability. For free motion quilting the fabric is moved back and forth under the foot by the sewer as stitching occurs, the key to obtaining the desired

stitches is moving the fabric at the correct speed, not too fast and not too slow.

**VIDEO DEMO:** [Darning & Freehand Embroidery Presser Foot Tutorial](#) (attention: the presser foot in the video has a metal part that attaches to the presser bar and our presser foot has a white plastic part)





## Sewing Machine Presser Foot Set - User Guide

### Adjustable Bias Binding Foot (29)



The bias binder foot is indeed a marvel. This presser foot comes in two types, the standard bias binder, and the adjustable bias binder. This is a great foot for home décor projects such as quilts and any other project that requires a binding. The foot can be used with commercially made bias binding or with bias binding that you make yourself. There are also bias making machines on the market now that make creating your own bias binding easy, as well as bias making rulers that assist the sewer in cutting the bias strips consistently the same width.

The adjustable bias binder is a clear plastic foot with a screw and markings on the foot that allow for the adjustment of the width of the finished binding. This foot is generally used to fold double-fold bias tape to the edge of a project, such as a quilt. The width of the finished binding is determined and the foot is adjusted to achieve the desired width. The foot has two screws, one to hold the bias strip while it is being sewn; the second screw is used to adjust the foot to the right or left of the needle so that the stitching catches the edge of the binding.

This foot is not suitable for quilt binding. While binding quilts there are too many/too thick layers for this foot.

**VIDEO DEMO:** [Bias Binding Foot Basics](#)

**VIDEO DEMO:** [Mitre Corners with a Bias Binding Foot](#)

**BLOG POST:** [Perfect Bindings in a Flash: How to Use a Bias Binding Foot](#)

**INFO PAGE:** [All About the Adjustable Bias Binder](#)

### Free Motion Darning Foot (30, 41 & 42)



Similar in use and function to the other Darning Foot (28). This Darning Foot has a transparent front that is a bit wider. This foot allows for a 7 mm extra wide zigzag stitch. The other one is limited to 5 mm. It is up to your personal preference which one of the two you want to use.

**VIDEO DEMO:** [How to sew using a Darning Foot](#)



## Sewing Machine Presser Foot Set - User Guide

### Adjustable Zipper Foot (31)



This foot is designed to facilitate the placement of stitching close to a raised edge: zipper insertion, corded seams, tubular cording, slipcover welting and similar applications.

The orange screw on the back allows you to adjust the foot very close to the work area either on the left or the right of the needle.

The foot is attached to the presser foot bar by removing the existing presser foot and shank and attaching the zipper foot, which has its own shank.

**VIDEO DEMO:** [Adjustable Zipper Foot](#)

### Knit Foot or Tricot Foot (32)

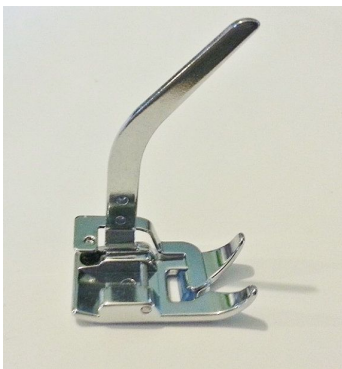

This foot is cleverly designed to hold the fabric down firmly as the needle comes down and pierces the fabric and then let up on the fabric as the feed dogs rise and carry the fabric along for the next stitch. There is a little rubbery plastic blue "stopper" piece that is controlled by the flange on the side of the foot. This flange fits nicely over the needle screw-bar. It moves as the needle bar moves, and there is a little spring that makes it - well - springy!

This knit foot perfect for lightweight knits and very slippery lightweight or stretchy fabrics of all sorts.

With the needle down in the fabric the lever is in the position where the spring pushes the plastic down on the fabric. Then, as the lever rises with the needle bar, it forces the plastic piece up off the fabric and another stitch is on the way!

Actually this foot does what a walking foot does but is a lot less complex and is simpler to install. For a detailed comparison of the two you can watch this video: [Walking foot vs knit foot - Which is the best for sewing knit fabrics?](#)

**VIDEO DEMO:** [How to Use a Knit Foot](#)



## Sewing Machine Presser Foot Set - User Guide

### Button Sewing Foot (33)



Designed for flat button work, you will be able to sew on multiple buttons in the time that it would normally take to hand sew one button. Featuring a textured rubber sleeve, the Button Sewing Foot securely holds everything in place so that your fingers can be a safe distance away from the needle.

**VIDEO DEMO:** [Button Sewing Link](#)

### Applique Foot(34)



The Applique Foot is the appropriate choice for people who love to do applique. Not only is the applique foot clear for visibility, and has the groove on the underside to let dense satin stitches pass, the Applique Foot excels over an open toe foot because of the short toes which allow tremendous maneuverability around tight curves.

**VIDEO DEMO:** [Applique Foot](#)

### Buttonholing Presser Foot (35)



The button hole foot is a sewing machine foot which simply clips onto the machine. Remove your current presser foot, and then clip the buttonhole foot on. You can make a buttonhole with a 1 step or 4 step buttonhole setting on your machine.

**BLOG INSTRUCTIONAL LINK:** [CLICK HERE](#)

**VIDEO DEMO:** [Buttonholing Presser Foot](#)



## Sewing Machine Presser Foot Set - User Guide

### Zipper Feet (36 & 37)



The zipper foot can be used for inserting zippers as well as making and inserting piping or cording. The zipper foot allows the needle to stitch close to a raised edge such as the teeth of a zipper or the thickness of cording. The zipper foot is truly an essential accessory for fashion sewing and home decor projects.

On most sewing machine models, the Zipper Foot can be attached to the presser foot holder on either the right side or left side. Depending on the type of zipper insertion, both sides may be used. For more information on the Zipper Foot for your machine model, refer to your sewing machine manual.

**VIDEO DEMO:** Zipper Foot ([Click Here](#))

### Low-Shank Adapter (43)



The Low-Shank Adapter is required for any machines that don't have a snap on and off feature. You simply attach it to your machine like any other low-shank foot and you can then snap-on and off all of the feet that require such a feature.

### Ultimate Threader (46)

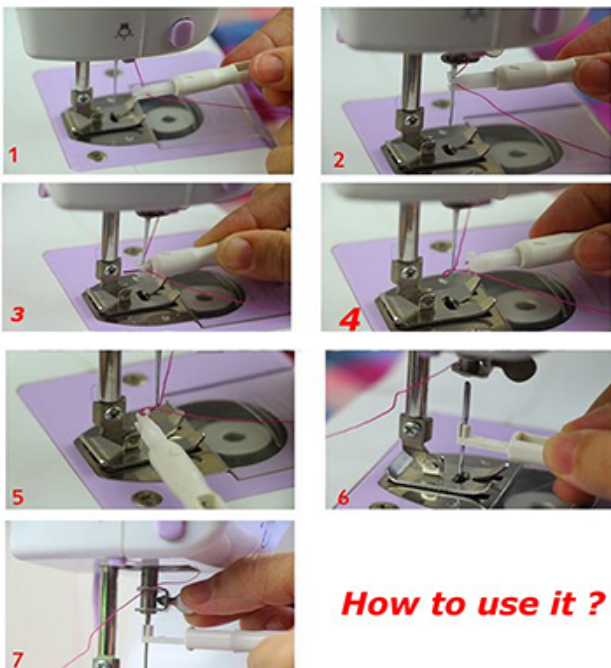

**How to use it ?**

This great tool helps you to thread your machine.

1. Turn off the power switch
2. Hold the grip of threader at the mark facing up. Guide the thread, inserting it into the Y-groove from right to left.
3. Place the V-groove over the needle just above the needle eye.
4. Slide the threader down the needle while pushing it gently until the threader pin goes into the needle eye.
5. Push the grip
6. Remove the threader from the needle slowly. Then pick up the loop with the hook pull the end of the thread out to the back.

**VIDEO DEMO:** [Click here](#)





## Sewing Machine Presser Foot Set - User Guide

### Universal Presser Feet (49 & 50)

These are universal standard presser feet which can be used for straight stitching to your preference.

### Whipstitch Presser Feet (51 & 52)

Whipstitch Presser Feet - Similar to cording feet, these are new to the set and we should have further information on using these soon.



# Sewing Machine Presser Foot Set - User Guide

## REFERENCES

1. [https://il.wp.com/il240.photobucket.com/albums/gg496/sewingsilly/13\\_zpsd9f59192.jpg](https://il.wp.com/il240.photobucket.com/albums/gg496/sewingsilly/13_zpsd9f59192.jpg)
2. <http://www.sewingmachinesplus.com/viking-braiding-foot-4118500-45.php>
3. <http://www.the-sewing-partner.com/braiding-foot.html>
4. [http://babylock.com/ftp/whitepapers/LNIS\\_BLDYFTKIT.pdf](http://babylock.com/ftp/whitepapers/LNIS_BLDYFTKIT.pdf)
5. <http://sewingmachine221sale.bizland.com/store/page60.html>
6. <http://www.the-sewing-partner.com/invisible-zipper-foot.html>
7. <http://blog.sewmucheasier.com/a-quick-guide-to-your-sewing-machine-presser-feet/>
8. <http://www.thecolorfulworldofsewing.com/Singer-Open-Toe-Embroidery-Presser-Foot.html>
9. <http://www.the-sewing-partner.com/cording-foot.html>
10. <http://www.sewingmachinesplus.com/BL-OCF.php>
11. <http://www.sewingmachinesplus.com/ESG-DS.php>
12. <http://www.the-sewing-partner.com/roller-foot.html>
13. <http://www.sew4home.com/tips-resources/sewing-tips-tricks/accessories-we-love-roller-foot-velvet-more>
14. <http://www.the-sewing-partner.com/darning-foot.html>
15. <http://www.the-sewing-partner.com/bias-binder-foot.html>
16. <https://eyeletsintheseams.blogspot.be/2010/06/janome-elna-tricot-foot.html>