



Sewing by Sarah

**32 PIECE
PRESSER
SET USER
GUIDE**



Sewing Machine Presser Foot Set - User Guide

I. WHAT IS IN THE BOX?2

II. HOW TO CHANGE THE FOOT ON A LOW SHANK SEWING MACHINE3

III. DESCRIPTION OF THE DIFFERENT FEET4

INVISIBLE ZIPPER FOOT (1)4

BRAIDING FOOT OR COUCHING FOOT OR CORDING FOOT (2).....5

DOUBLE WELTING FOOT OR PIPING FOOT (3)8

FRINGE FOOT OR LOOPER FOOT (4)9

5/7 HOLE CORDING FOOT (5 & 10)10

APPLIQUE FOOT (6).....11

1/4 " QUILTING FOOT (7).....11

7/9-GROOVE PINTUCK FOOT (8 & 9)12

SATIN STITCH FOOT (11)13

PEARL PIPING FOOT/BEADING FOOT (12).....13

1/4 " QUILTING FOOT WITH GUIDE (13).....15

EDGE JOINING FOOT OR STITCH-IN-THE-DITCH FOOT (14).....16

OPEN TOE EMBROIDERY FOOT (15).....17

JAGUAR FOOT (16).....17

SHIRRING FOOT/GATHERING FOOT (17).....18

DARNING FOOT (18)19

OVERCAST FOOT (19)20

CORDING FOOT (20).....21

TEFLON ZIGZAG FOOT (21).....22

OPEN TOE PRESSER FOOT (22).....22

STRAIGHT STITCH FOOT (23)23

HEMMER FEET (24 AND 26)24

ROLLER FOOT (25)25

BLIND STITCH FOOT/BLIND HEM FOOT (27).....26

DARNING FOOT/FREE MOTION FOOT (28)27

KNIT FOOT OR TRICOT FOOT (29)28

ADJUSTABLE ZIPPER FOOT (30)29

ADJUSTABLE BIAS BINDING FOOT (31)30

STITCH GUIDE FOOT (32).....31

I. What is in the box?

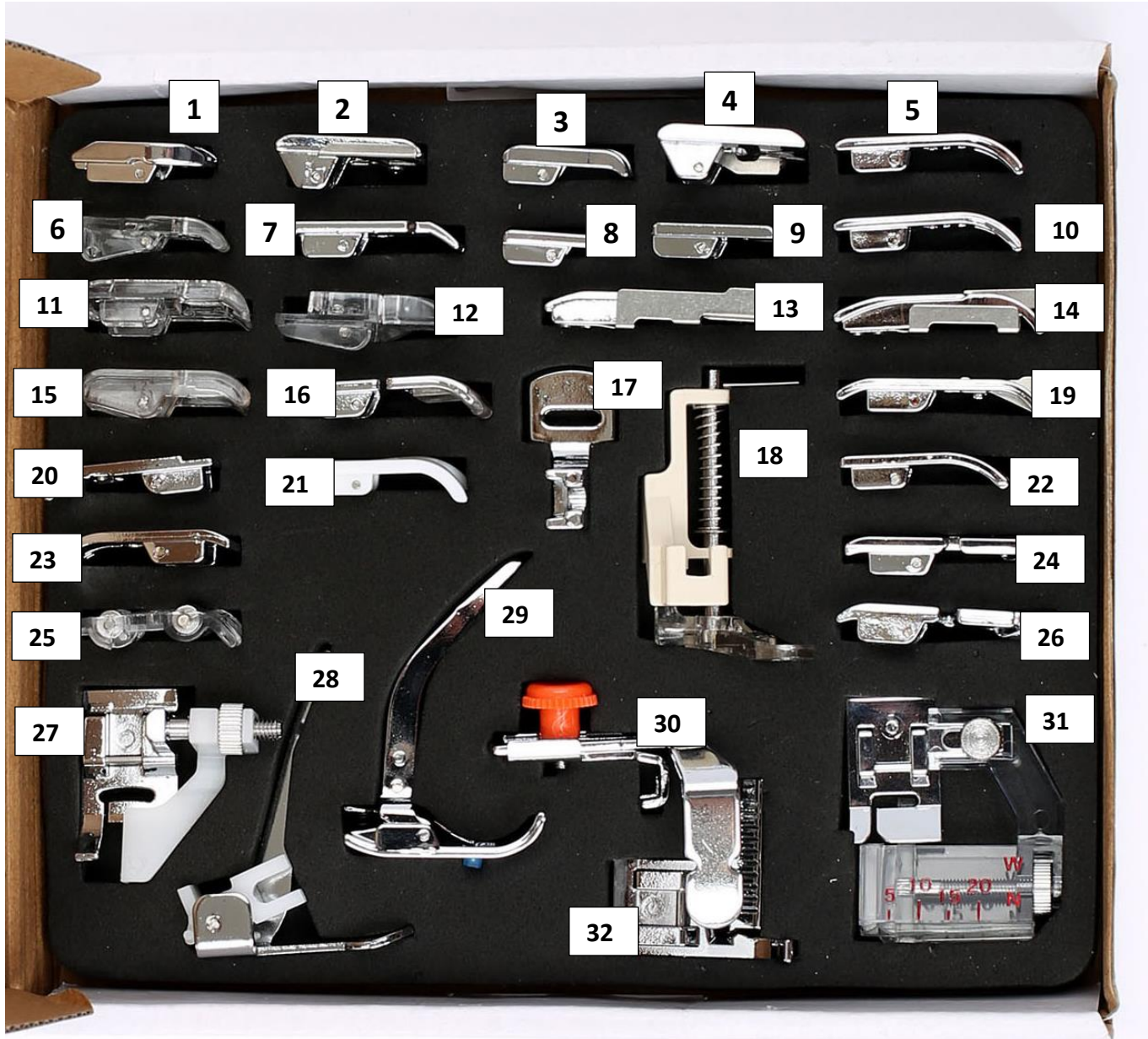

| | | | |
|--------------------------|---------------------------------------|------------------------------|--------------------------------------|
| 1. Invisible Zipper Foot | 9. 7 Groove Pintuck Foot | 17. Gathering Foot | 25. Roller Foot |
| 2. Braiding Foot | 10. 7 Hole Cording Foot | 18. Darning Foot/Free Motion | 26. Hemmer Foot |
| 3. Double Welting Foot | 11. Satin Stitch Foot | 19. Overcast Foot | 27. Blind Stitch Foot |
| 4. Fringe Foot | 12. Round Bead Foot | 20. Cording Foot | 28. Darning Foot Low Shank |
| 5. 5 Hole Cording Foot | 13. 1/4" quilting foot with guide | 21. Zig Zag Foot | 29. Knit Foot |
| 6. Applique Foot. | 14. Edge Joining/Stitch in Ditch Foot | 22. Open Toe Foot | 30. Zipper Foot Low Shank |
| 7. 1/4" quilting foot | 15. Open Toe Embroidery Foot | 23. Straight Stitch Foot | 31. Adjustable Bias Tape Binder Foot |
| 8. 9 groove pintuck foot | 16. Jaquar Foot | 24. 1/4" Rolled Hem Foot | 32. Stitch Guide Foot |

II. How to change the foot on a low shank sewing machine

VIDEO DEMO: [Changing Your Sewing Machine Feet](#) (click

to view) Removing a presser foot:

Raise the needle and the presser foot lever.

The way to remove the presser foot depends on the brand of machine you have. Sometimes it just snaps off, but with most machines you have to push a button or lever on the presser foot holder. Consult your machine's user manual to find the way to remove the presser foot.

Attaching a presser foot:

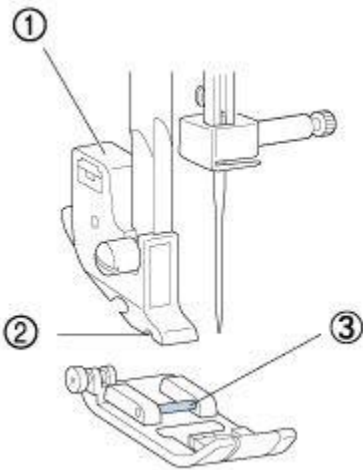

Lower the presser foot lever so that the presser foot pin (3) snaps into the shank (2) in the presser foot holder (1). You may have to try a couple of times before it snaps in. If your presser foot holder has a lever or button for release, it may be necessary to pull/press it to facilitate snap-on.

The presser foot holder can look different on your machine, this picture is from a Brother sewing machine.

[To download our FREE Presser foot guide that you can leave with your sewing machine, click HERE.](#)

The guide has a picture and a description and the guide is separated by usage, so it makes it easy to find the foot you need for the job!

III. Description of the different feet

Invisible Zipper Foot (1)



The invisible zipper foot is a presser foot designed for installing invisible (or concealed) zippers. The top of the invisible zipper foot has a single, small hole for the needle. On the bottom, there are two grooves that run side-by-side down the length of the foot. These grooves fit over the teeth of the zipper to allow the stitching to fit as close to the zipper teeth as possible. Conventional lapped or centered zippers use top stitching and folded fabric, while invisible zippers disappear into the seam of whatever garment, purse, cushion, or other project you are finishing. The close, even stitching enabled by the invisible zipper foot creates the smooth, concealed appearance that invisible zippers are known for.

Invisible zippers can be used with any weight of fabric and for any project in which a concealed zipper will enhance the finished product. For example, an invisible zipper is appropriate for tailored garments like pencil skirts or accessories like purses or pillow covers. The invisible zipper provides a smooth, polished appearance, especially when compared with the textured closure of a lapped zipper. In addition, using an invisible zipper as a closure for striped, plaid, or patterned fabrics can allow you to match patterns across seams.

VIDEO DEMO: [Click here to see the video on our Youtube channel on how to install the zipper foot and sew on your zipper.](#)

INFO PAGE: Our blog has a full tutorial on how to install a zipper foot:
<https://sewingbysarah.com/blogs/tutorials/how-to-install-an-invisible-zipper>

Braiding Foot or Couching Foot or Cording Foot (2)



The braiding foot is a presser foot designed to attach braiding, cord, rat tail, or other decorative enhancements. The braiding foot consists of an adjustable plate with a rectangular hole in the middle centered above the “V” of the foot. There is a depressed groove on the leading edge. To use the braiding foot, feed the trim through this opening and under the foot. As you sew, the trim will move automatically through the foot, so you can apply trim for any purpose your project requires. Traditional embellishments like braiding are hand-sewn; using the braiding foot can help you more quickly and easily give your products an heirloom appearance.

Use the braiding foot to attach trim to a variety of handcrafts, including garments, wall hangings, quilts, upholstery, or any other project that could benefit from a final design finish. Braids and trims can be used as applique borders, seam covers, or decorative fabric finishes.

VIDEO DEMO: [Add dimension with the braiding foot](#) (click to view)

1. Select a straight stitch or a zigzag stitch. Most of the time you will want to use a zigzag stitch.
2. Place the width of the zigzag just wide enough to clear the braid, cord, or elastic that you are using.
3. Loosen the screw on the left of the foot to allow you to move the adjustable plate forward and back to accommodate varying widths of braid, cord, or elastic.



Sewing Machine Presser Foot Set - User Guide

4. Snug the plate close to the braid that you are applying to help guide the braid. Let the braid feed in as you guide the fabric on the transferred design.

Instructions for couching elastic



1. Thread the elastic through the hole on the braiding foot from the top and under the back of the foot. Move the guide by loosening the screw and snugging it up to the elastic but allowing the elastic to slide through freely.
2. Select the overcast stitch, adjusting the width to cover the elastic.
3. Begin sewing letting the elastic slide through the foot as you sew.
4. Pull the elastic up to the degree of gathers as desired. the elastic should slide easily in the thread casing.

Instructions for gathering with elastic



1. Mark the placement of the elastic.
2. Feed the elastic through the hole on the front of the foot and under the back. Slide the metal guide around the elastic and tighten the screw. The elastic should be able to slide easily through the hole.
3. Select the appropriate tape attaching stitch on your machine. Lower the needle and take a few stitches to hold the elastic in place.



Sewing Machine Presser Foot Set - User Guide

4. As you start sewing, stretch the elastic in front of the foot. The fabric will begin to gather behind.

Instructions for trim with twin needle



1. Position the ribbon or trim in the spot desired. Select the twin needle width desired.
2. Thread the ribbon or trim through the braiding foot and tighten the screw.

Instructions for piping designs



1. Draw your design on your fabric first.
2. Back the fabric with tear-away stabilizer.
3. Thread the soutache cord through the hole on the front of the foot and under the back. Move the metal slide close around the trim.
4. Lower the needle into the center of the trim and begin sewing.
5. As you sew curves, do not pull the trim too tight as you sew.
6. Be sure to keep the needle in the center of the trim. Use your presser foot lifter to pivot as you sew.

Double Welting Foot or Piping Foot (3)



The double welting/double piping foot is a presser foot designed specifically for creating single or double piping or welting. The two grooves on the bottom of this presser foot provide room to allow one or two lines of piping to pass underneath. The double piping foot accepts 4mm to 6mm piping or cording and has a maximum stitch width of 4mm.

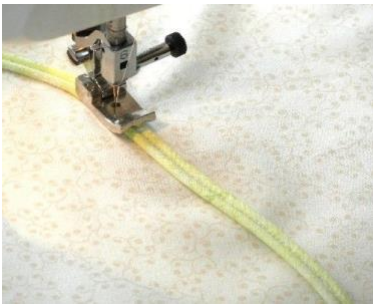

Piping and welting are often used to finish home décor projects. This presser foot can be used to create many effects, including making single- or double-piping using bias tape and cord; attaching couch cord or piping; and attaching covered single- or double-piping. For example, when working with furniture pieces, double welting cord used with upholstery fabric can be glued over the exposed staples on the front of a sofa or chair. To create a tailored appearance, use narrow, flexible piping to cover the finishing seams of your project.

Topstitching double piping can cover seams or highlight fabric designs, and double welting cord sewn underneath fabric creates welted texture to enhance finished products.

Check out our blog post on adding piping here (video included):

<https://sewingbysarah.com/blogs/tutorials/adding-piping-to-your-projects>

Fringe Foot or Looper Foot (4)



The fringe foot (or “looper foot”) is a presser foot that allows quilters and other textile manufacturers to add decorative accents to completed products. The fringe foot adds a zig-zag stitch over the center raised bar. With more thread added to each stitch, a straight line of stitches made with the fringe foot creates a row of raised loops. A narrow zig-zag of loops sewn with a short stitch length produces lines, curves, and other shapes to create decorative highlights.

For example, a floral pillow cover can be finished by adding a textured outline made with zig-zag loop stitches. Add texture and create a chenille effect by juxtaposing several rows of wider stitching. Similarly, a plain purse can be transformed to a chic design by using the fringe foot to add texturing, which can be applied to any type of design. Depending on the stitches available on your machine, these looped effects can be enhanced to produce rows of eyelash fringes or a faux fagoting stitch.

VIDEO DEMO: [How To Use a Fringe Foot](#) (click link to view)

BLOG POST: [4 Fun Ways to Use a Fringe Sewing Foot](#) (click link to view)

5/7 Hole Cording Foot (5 & 10)



The cording foot is a presser foot designed to couch anywhere from 1 to 7 individual lengths of fine cord, thread, or string. Unlike the welting or piping foot designed to handle large trim, cording feet are designed for fine trim. The cording feet have holes in the front designed to hold the cord or thread. Depending on which cording foot you decide to use, the cording foot will have either 5 or 7 holes. To use a cording foot, run the cord, thread, or string through the holes in the front and out the back. Set the needle to either a plain, decorative zigzag, or overcast stitch slightly wider than the furthest edge of the trim. Move the fabric under the foot so the trim moves with it; the stitches will rest across the top of the trim and hold it firmly to the fabric.

VIDEO DEMO: [How to use a 5 hole cording foot](#)

There are many uses for cording feet, which can accommodate almost any type of fabric or material. Fine cord, embroidery silk, metallic thread, yarn, or threads used for couching stitches can be used singly or combined to create a variety of effects. For a subtle effect using a cording foot, couch one fine thread with monofilament to create an embroidery pattern. For a bolder effect, multiple strands of embroidery silk and metallic thread couched using a decorative zigzag stitch can add texture and color. Alternatively, several neutral colored cords couched next to each other and intersected at right angles with a similar pattern can create sleek design highlights. These techniques can be used to finish garments; accessories; home décor; quilts; and wall hangings; or to outline appliques and perform free-form embroidery.

Applique Foot (6)



- Ideal for precision embroidery, applique, cutwork and monogramming. Nothing stands in the way of your creative vision. The cutout on the underside of the foot accommodates satin stitching and the clear plastic ensures greater visibility while sewing. The bottom of the foot has a wedge shaped indentation, which allows even satin stitching to glide under the foot without dragging. The angle in the indentation makes it possible to turn curves easily. The toes of the foot are shorter, compared to a regular zigzag foot, for greater maneuverability while sewing (you can turn the fabric more easily for smoother stitching lines, an important asset when embellishing fabric)

1/4 " Quilting Foot (7)



The 1/4" quilting foot and the 1/4" quilting foot with guide are presser feet designed specifically for sewing neat, straight, 1/4" seams. The important part of this presser foot's name is "1/4"". The regular 1/4" quilting foot has a wider back surface that narrows in the front into two asymmetrical toes. The outer edge of the wider toe on the right marks the 1/4" seam allowance. The raised markings on the metal are designed to assist with measuring—the wider distances on the right side are each 1/4" apart, and the narrow markings on the left side are each 1/8" apart. These markers act as guides to help you create clean, precise corners and crossings by pivoting at the



Sewing Machine Presser Foot Set - User Guide

right spot. This foot also features a small, round needle in the middle designed for creating straight stitches with greater precision and a large foot area designed for holding fabric firmly in place.

Check out our blog post on using this foot here:

<https://sewingbysarah.com/blogs/tutorials/the-1-4-presser-feet-game-changer>

7/9-Groove Pintuck Foot (8 & 9)



Pintuck feet are presser feet designed for sewing pintucks. From the top, the pintuck foot appears to have little teeth at the front; from the bottom, these teeth appear as little grooves that run the length of the foot. The differences between the types of pintuck feet are in the number of grooves running along the bottom. To sew pintucks, combine the pintuck foot with a double needle. The double line of stitches pulls the fabric into the grooves, and the multiple grooves help keep the pintucks evenly spaced and aligned.

Pintucks and smocking can provide traditional decorative finish to garments and are common in heirloom and custom apparel. Using a pintuck foot can make adding these embellishments less labor intensive than adding them by hand. Pintuck feet are also useful for creating faux smocking. By varying the width and quantity of pintucks, you can provide texture and design to any flat expanse of fabric and any type of textile project.

VIDEO DEMO: [How to Use a Pintuck Foot](#)

VIDEO DEMO: [How To Use A Pin Tuck Foot with Cording](#)

Satin Stitch Foot (11)



The satin stitch foot is a presser foot designed for creating satin stitches to decorate finished products. This foot's guide notch is designed to keep the satin stitch right on the edge of an applique or pattern marking, making it ideal for satin stitching. The satin stitch foot is similar to the open toe/ embroidery feet, but the satin stitch foot maintains a bridge between the toes. The bridge of the stain stitch foot includes a guide notch that help keep stitching lined up precisely. This foot's needle hole is wide to accommodate wide, zigzag decorative stitches or true satin stitch settings. This foot also has a groove on the bottom to accommodate the height and bulk of closely spaced stitches.

VIDEO DEMO: [How to sew using a Satin Stitch Foot](#)

Pearl Piping Foot/Beading Foot (12)



The beading foot is a presser foot designed to attach round trim, such as strings of pearl beads or piping up to 1/4" thick. A tunnel that runs under the beading foot allows the trim to pass securely underneath while sewing, while the clear plastic design allows maximum visibility. If



Sewing Machine Presser Foot Set - User Guide

your machine allows you to move the needle from left to right, you can also use the beading foot to attach piping or corded pintucks.

Pearl bead trim is commonly used in formal wear, especially for bridal wear, but it can be used for many types of garments. Pearl bead trim is also useful to ornament housewares, wall hangings, and heirloom children's wear.

Colored beads can be used to accent fun fashions, and the beading foot can be adapted to attach sequins.



1/4 " Quilting Foot with guide (13)



The 1/4" quilting foot with guide is a presser foot designed specifically for sewing neat, straight, 1/4" seams. The important part of this presser foot's name is "1/4". The regular 1/4" quilting foot has a wider back surface that narrows in the front into two asymmetrical toes. The outer edge of the wider toe on the right marks the 1/4" seam allowance. The raised markings on the metal are designed to assist with measuring—the wider distances on the right side are each 1/4" apart, and the narrow markings on the left side are each 1/8" apart. These markers act as guides to help you create clean, precise corners and crossings by pivoting at the right spot.

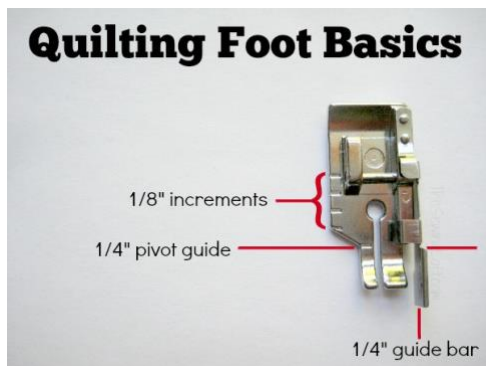

Tips:

- It can **only** be used in a single needle application with the center straight stitch.
- The markings on this foot are measurement guides designed to help keep your stitches exact.

Tips for using the Quilting Foot:

1. Align the raw edge of two fabric layers against the guide at right side of foot. Lower foot and stitch away.
2. The narrow toe on the left side can be used as a guide for small piece work or mini quilts.
3. Maintaining a perfect 1/4" seam while turning a corner is easy. Stitch until the edge of fabric aligns with the mark on the narrowest part of foot; leave needle and down position, lift up pressure foot and pivot. Return presser foot to down position and



Sewing Machine Presser Foot Set - User Guide

continue stitching with fabric against the guide. This technique works for both quilting and top stitching.

Check out our blog post on using this foot here:

<https://sewingbysarah.com/blogs/tutorials/the-1-4-presser-feet-game-changer>

Edge Joining Foot or Stitch-in-the-Ditch Foot (14)



The edge-joining/stitch-in-the-ditch foot is a versatile presser foot that is most frequently used either to join two finished edges laying side by side or to stitch “in the ditch” (directly on top of another seam). The edge-joining/stitch-in-the-ditch foot resembles an all-purpose foot, except that it has a blade attached to one side that runs straight down the middle of the foot. Turn the foot over to see how the blade extends past the point where the toes of the foot begin their upward curve. The blade is designed as a guide for ensuring precise, accurate stitching. This foot’s wide needle opening allows for zigzag or other decorative stitches that join two flat pieces of fabric.

Edge-joining is a technique commonly used with heirloom clothing, wherein two finished pieces are joined together from the right side, especially when attaching lace to an edge. Of course, attaching lace is not limited to heirloom sewing. Wherever a project requires an edge, you have an opportunity to use lace to make it more elegant, including projects like pillow cases, curtains, handkerchiefs, napkins, collars, sleeves, and hems.

VIDEO DEMO: [How to Use the Edge Joining Foot](#)

Check out our blog post on [Stitch in the Ditch](#) here:

<https://sewingbysarah.com/blogs/tutorials/what-is-stitch-in-the-ditch-or-ditch-stitch>

Open Toe Embroidery Foot (15)



The open toe and open-toe embroidery feet are versatile presser feet designed specifically for stitch patterns that need lots of room. The regular open toe foot is made of metal; the open-toe embroidery foot is made of clear plastic. Each of the presser feet in this set has a wide-open space between their two slim outer toes and a wide groove on the bottom. The wide space between the outer toes of each foot is designed to accommodate extra-wide zigzag stitches, decorative stitches, and any other stitch pattern that requires additional space for the needle to move. The groove on the underside of each foot allows the bulk of dense stitch patterns to pass underneath.

VIDEO DEMO: [How to sew using an Open Toe Embroidery Foot](#)

Jaguar Foot (16)





Sewing Machine Presser Foot Set - User Guide

The jaguar foot is a utility foot primarily used with a zigzag stitch. It has a clear front making it easy to line up your stitches and insure even placement

Shirring Foot/Gathering Foot (17)



The shirring foot (or gathering foot), is a presser foot designed for gathering fabric by sewing across it. Instead of snapping this foot onto your machine, attach it using the screw on the shank. The top of the foot is flat and has a wide needle opening. On the bottom, a wide, flat piece runs across the front. A narrow slot runs horizontally between these two flat pieces. No part of this foot presses the fabric down firmly onto the throat plate; instead, as the needle moves up and down through the fabric, the needle's pulling motion combines with the stitch length and the thread tension to create a gathering effect. Using the slot between the upper and lower plates, you can attach a second piece of fabric that will not be gathered. This technique can be used when you want to gather a skirt while simultaneously attaching an ungathered bodice.

Shirring, gathering, and ruffling are used for many kinds of decorative and practical sewing effects; a single line of gathering is necessary when creating many types of skirts and sleeves.

Shirring is a technique used to sew several lines of gathered stitches, each at a regular distance from one another, to create a textured area. Gathering—also called ruffling—is a technique used to sew a line of gathered stitch to take in fullness at the top of a piece of fabric. Use the shirring foot to create either effect. The shirring foot is different from a true ruffler foot, which is designed specifically to create small pleats rather than gathers. Traditionally, shirring is associated most closely with heirloom sewing, but it can be adapted for many uses. Shirring creates texture across any flat front, and diagonal shirring can give bags or pillows a modern appearance.

VIDEO DEMO: [How to Use a Gathering Foot](#)

INFO PAGE: [All About the Gathering Foot](#)

Darning Foot (18)



The darning feet are presser feet designed to allow the greatest possible freedom of movement, with the least interference from the presser foot and feed dogs as possible, for sewing projects that include darning, free-motion quilting, and machine embroidery. The two darning feet in this set look very different, but they are designed to accommodate the same demands. Examine these feet side-by-side to see how both feet have a needle opening in a circular area of the foot. The metal darning foot has a large, round opening; whereas the plastic foot has a wide, slit opening. Rather than snapping them into place, both of these feet should be screwed onto your machine.

Place the squared plastic pieces over the shank and foot screw of the sewing machine, then tighten the screw. Both feet have a mechanism that fits over the needle screw that allows the feet to rise and fall with the movement of the needle. This movement holds fabric down as the needle enters, while allowing maximum movement of the fabric when the needle is in an up position. On the metal foot, this mechanism is the long arm that angles up from the bottom; on the plastic foot, it is the metal bar horizontal to the spring. Both feet are designed to minimize movement of fabric through the sewing machine, so you can more directly control stitch length and direction. These feet are most effective when the feed dogs on your machine are dropped or covered.



Sewing Machine Presser Foot Set - User Guide

VIDEO DEMO: Darning & Freehand Embroidery Presser Foot Tutorial (attention: the presser foot in the video has a metal part that attaches to the presser bar and our presser foot has a white plastic part)

DEMO: [How to sew using a Darning Foot](#)

Overcast Foot (19)



The overcast foot is a presser foot designed for finishing raw edges or for sewing stretchy seams. The overcast foot produces stitches that wrap over the edge of the fabric with an effect similar to a serged edge. A seam guide sticks out along the right toe of this presser foot, with a small metal tongue that extends across the center of the needle opening. Unlike the seam guides of many presser feet, this guide is located on the left side of the right toe and is designed to keep the fabric edge to the left of the furthest reach of the needle. As a result, stitches made with this foot wrap around the outer edge of the fabric, rather than piercing it. In addition, the center tongue holds the thread off the fabric. This effect keeps the stitches from being pulled too tightly and prevents the edge of the fabric from rolling up.

VIDEO DEMO: [How To Use an Overcast Foot](#)

Cording Foot (20)



The 3-hole couching foot is a presser foot designed to couch decorative trim onto fabric. This presser foot is related to the 5- and 7-hole cording feet. Although it looks different, it serves a similar function. The front cross-piece of this presser foot has 3 covered grooves designed to hold up to three lengths of yarn, cord, thread, or other trim. Compared to the 5- and 7-hole cording feet, the holes in the 3-hole couching foot are larger in diameter and allow you to use thicker trims. In fact, this presser foot is often referred to as a “yarn couching foot” because the holes are large enough to accommodate some types of yarn. The 3 grooves on the bottom of this presser foot are matched to the 3 holes in the front cross-piece to allow the foot to pass over couched trim. This presser foot also has a different overall shape than either the 5- or 7-hole cording feet. The 3-hole couching foot is open on one side and has a single, pronounced toe on the other. This minimalist design contributes to greater visibility and enhances maneuverability.

VIDEO DEMO:
[How To Use A Cording Foot](#)

Teflon Zigzag Foot (21)



The non-stick foot is a presser foot designed for “sticky” fabrics like leather, pleather, vinyl, coated fabrics, and other heavy synthetics. Although the non-stick foot looks like a regular all-purpose foot, it is made of plastic to accommodate for sewing heavy fabrics, which tend to stick to metal presser feet or the feed dogs. By allowing “sticky” fabrics to pass smoothly and evenly underneath the presser foot, the plastic non-stick foot can help you avoid shortened and uneven stitches; stretched, warped, or torn fabric; and broken thread. The non-stick foot can help you create products with crisp, even stitching.

Open Toe Presser Foot (22)



The regular open toe foot allows you to expand the uses of these feet beyond embroidery. The open-toe foot is ideal for outlining applique. Its increased visibility lets you see the needle’s location at all times, so you can exercise more control around tight curves and turn precise corners. Use a satin stitch or a short, narrow zigzag for applique. Using a longer zigzag stitch can



Sewing Machine Presser Foot Set - User Guide

produce a more rustic look. Experiment with your decorative stitches using the open toe foot to produce different effects when working with applique. The open toe foot can also be used for edge stitching, flat joins, or anywhere else that higher visibility is helpful.

Straight Stitch Foot (23)



The straight stitch foot is a presser foot designed specifically for creating durable, even seams sewn with a dependable straight stitch. This presser foot's design is the opposite of the minimalist, open design used for the embroidery foot. The needle opening on the straight stitch foot is very small, and the only other open space is the thin line between the toes. This opaque design allows the presser foot to maintain even pressure on fabric, especially around the area where the needle pierces the fabric. Thus, by holding the fabric steady, the needle can punch through to produce clean, even straight stitches.

blog post

Hemmer Feet (24 and 26)



The hemming feet are presser feet designed to create hems. This set It contains four different hemming feet. Two of the hemming feet are round hemming feet; the other two hemming feet are narrow hemming feet.

The round hemming feet have a rounded groove on the bottom. The narrow hemming feet have a squared, shallower groove on the bottom. The two different types of hemming feet also each vary in width to accommodate either 3mm or 6mm hems. A scroll clip is attached to the long, square right toe on the top of each of the hemming feet. The wide needle hole at the top of the foot is designed to accommodate proper needle position for hems using the narrow feet, or a true rolled hem with a centered zigzag using rounded hemming feet.

Both the rounded hemming feet and the narrow hemming feet turn fabric under into a narrow double hem. The double fold of the fabric wraps around the scroll clip with the raw edge in the center. As the fabric moves through the presser foot, it continues folding over into a narrow double hem. Sew the hem with a straight or zigzag stitch, depending on which foot you use and the desired effect of the hem.

Use the rounded hemming feet and a zigzag stitch to pull the folded hem into a dense, rounded edge with more vertical body than a flat, narrow hem. Or use the rounded hemming feet and a straight stitch to create a regular flat narrow hem.

Check out our blog post using the hem foot here:

<https://sewingbysarah.com/blogs/tutorials/making-napkins-for-the-holidays>

VIDEO DEMO: [How To Sew Rolled Hems with the Harrow Hemmer Foot](#)

Roller Foot (25)



The roller foot is a presser foot designed for sewing difficult to manage fabrics like leather, pleather, velvet, knits, organza, and chiffon. This presser foot is mostly transparent and has two upturned toes at the front designed specifically for handling layers and thick fabrics. A wide, textured roller made of metal lies behind the toes in front. Two more rollers that look more like small wheels occupy the back of the foot. Heavy fabrics that get stuck moving along the bottom of standard presser feet move more easily over these rollers, which also provide even pressure without restricting the movement of the fabric. The metal is scored with a crosshatch texture that provides enough of a grip on the fabric to move it past the needle without any catching, snagging, or distorting. In addition, the needle opening is wide enough to accommodate a variety of zigzag or decorative stitches.

The roller foot has more uses than some feet designed for difficult fabrics. Use this foot when working with fabrics that are too thick, stiff, sticky, slippery, stretchy, flimsy, or thin for other presser feet. For example, the nonstick foot or the knit foot are each designed specifically for one kind of difficult fabric, but the roller foot can handle chiffon as just as well as leather, and velvet just as well as vinyl. In addition, the roller foot maintains pressure on fabric while sewing, unlike the walking foot; and its wide design and rollers stabilize fabric more effectively than a standard all-purpose foot.

Blind Stitch Foot/Blind Hem Foot (27)



The blind hem foot is a presser foot specifically designed for producing the polished appearance of a blind hem. Creating a quality blind hem by hand can be very difficult. Using a machine can often produce better results, and this presser foot can help you get the results you want.

VIDEO DEMO: [How to Use a Blind Hem Foot](#)

VIDEO DEMO: [How To Blind Hem Trousers](#)

Darning Foot/Free Motion Foot (28)



The darning foot is a multi-purpose foot, not only is it used for embroidery, but it is also used for free motion quilting and of course darning, which is also just basic, old fashioned garment mending.

Attaching the foot:

The foot is attached to the presser foot bar by removing the existing presser foot and shank and attaching the darning/embroidery/quilting foot, which has its own shank. You will need to ensure that the long arm of the foot is positioned above the crew which holds the needle in place. This will drive the movement of the foot in time with the drop of the needle allowing the user to move the fabric freely and the feed dogs are not used for this foot.

Using the foot

When using this foot the feed dogs must also be either dropped or covered. For embroidery and darning the fabric project should be hooped for stability. For free motion quilting the fabric is moved back and forth under the foot manually by the sewer as stitching occurs, the key to obtaining the desired stitches is moving the fabric at the correct speed, not too fast and not too slow.

Practice is definitely recommended for the free motion quilting and embroidery uses of this foot.

Knit Foot or Tricot Foot (29)



The knit foot is a presser foot designed for sewing delicate, stretchy fabrics, especially knits. Sewing knits is a high-demand skill. Although the walking foot can be used, the knit foot eliminates the walking foot's even feed feature, so it is simpler and easier to use. This foot clips in place like most standard presser feet. The top of the foot has two curved toes. An angled channel between the toes leads to a wide needle opening. In addition, a piece that resembles a clip at the top of the foot attaches to a tall arm on the side of the foot at the back. Hold the foot and move the arm to see how this attachment has some give. Turn the foot over to see how the bottom of the clip piece is capped with a soft plastic stopper. When the arm moves, this piece moves up and down, as well.

The plastic piece is instrumental in controlling the movement of knits and other slippery fabrics. When this foot is installed, the long arm fits over the screw that holds the needle. As the needle moves up and down, the arm moves with it, alternately pressing the plastic piece that caps the clip down into the fabric, or lifting it up away from the fabric. When the stopper presses down as the needle enters the fabric, the fabric is held firmly in place; when the stopper lifts as the needle moves up, the fabric is free to move smoothly under the foot for the next stitch. The wide needle opening accommodates zigzag, overcast, or stretch stitches, all of which are commonly used when sewing knits.

Despite this presser foot's name, it can be used with many types of fabrics in addition to knits. For example, chiffon, organza, light silks, slippery satin polyesters, and stretchy fabrics like fleece can be difficult to control when using an all-purpose foot. Whether due to the slippery nature of the fabric or too much pressure or instability from the foot, needle motion may drag these types of fabrics into the throat plate. The movement and firm hold of the knit foot's stopper can help to solve all these problems.

VIDEO DEMO: [How to Use a Knit Foot](#)

Adjustable Zipper Foot (30)



The adjustable zipper foot is a presser foot designed for installing zippers quickly and easily. Normally, this foot is used for standard zippers, which are also called “centered” or “lapped” zippers. The adjustable zipper foot consists of one narrow, metal piece with small notches on either side. The notches are designed to serve as needle openings. This presser foot should be screwed in place using the flat metal piece on the back of the foot. Slide this piece into the clip that holds the foot to the sewing machine shank. This sliding piece held in place by the plastic screw acts as the adjustable zipper foot.

Read our Full Blog post tutorial here:

<https://sewingbysarah.com/blogs/tutorials/how-to-sew-a-zipper-in>

VIDEO DEMO: See our full playlist on sewing a zipper with this foot on Youtube:

https://www.youtube.com/playlist?list=PLxg1YpUz9KWzCQihhM2JqL-ax_CK9Qs5I

Installation Video:

https://www.youtube.com/watch?v=JLCu83eRM4o&list=PLxg1YpUz9KWzCQihhM2JqL-ax_CK9Qs5I&index=2

Adjustable Bias Binding Foot (31)



The adjustable bias binding foot is a presser foot designed exclusively for sewing bindings—usually bias bindings, although it can accommodate straight grain bindings, as well. The adjustable bias binding foot has a complicated appearance, but using this foot to apply binding can be much simpler than applying binding using a standard presser foot. Most of this foot is made of a plastic part that is designed to be used as a guide. The plastic part on the left edge of the foot has a slot right down its length. At the front of the slot on the left edge, small tabs run down from the top, up from the bottom, and curve over, ending in two small notches along the short edge of the plastic. These two notches serve as the guides for the edges of the binding. The metal part of the foot curves up in front to accommodate layers of fabric and the binding material.

The needle opening places the needle at the edge of the binding and is wide enough to accommodate zigzag or decorative stitches. There are two screws in the front and back of the foot. The front screw on the plastic at the front moves the inside part of the guide. This screw should be adjusted depending on the width of the binding using the markers on the top, which are spaced at millimeter intervals. The screw on the back of the foot holds the plastic guide onto the metal foot. Loosen this screw to adjust the guide back-and-forth to ensure optimal needle placement. This feature is particularly important for machines that do not have an adjustable needle.

Here's a video on making bias tape that includes using this foot:

<https://sewingbysarah.com/blogs/tutorials/how-to-make-bias-tape>

VIDEO DEMO: [Bias Binding Foot Basics](#)

VIDEO DEMO: [Mitre Corners with a Bias Binding Foot](#)

BLOG POST: [Perfect Bindings in a Flash: How to Use a Bias Binding Foot](#)

INFO PAGE: [All About the Adjustable Bias Binder](#)

Stitch Guide Foot (32)



The stitch guide foot is a presser foot designed for maintaining seam allowances that other feet may not control as effectively. The stitch guide foot has an odd appearance, but it can be a very valuable tool, especially when you are trying to maintain seam allowances that may be wider than what other presser feet typically accommodate. The single toe on the left side of this presser foot is designed to control fabric, especially when you are working with multiple layers. The extra wide needle opening is designed to accommodate a variety of stitches. The stitch guide—a wide, flat rectangle with marks on it—occupies the right side of the foot. The marks on the stitch guide occur at 2mm intervals to allow for the precise gradation of seam allowances. To use this foot, line up the edge of the seam with the appropriate marking, then apply the stitch. The guide on this presser foot helps to keep the lines of stitching stay consistently straight and evenly spaced from the edge, with the shorter intervals of the stitch guide especially helpful for maintaining seam allowances around curves.

VIDEO DEMO: [Stitch Guide Foot](#)