

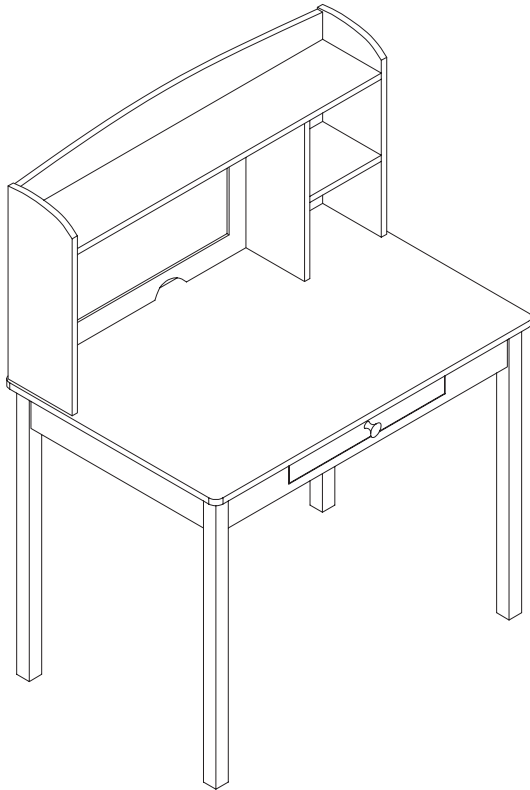

www.gltc.co.uk

## Whittington Desk & Hutch



Assembly Difficulty



easy - medium - hard



two-person job

V4

29/04/2020

**Thank you for shopping with GLTC, we hope you enjoy having this product in your home.**

We know assembling furniture, toys or accessories is not everyone's favourite way to spend their time, so we've tried to make assembling this item as quick and painless as possible.

Hopefully our efforts will have been worthwhile and you'll sail through the whole process. But if it all feels a bit too much like hard work, then we do have an assembly company we can recommend: the Flatpack Construction Company offers a nationwide service and can be contacted on **0843 289 4951** or **www.flatpackconstruction.co.uk**.

### **A few important pointers before you start:**

- Please read the instructions right through before you start, and check that all the components have been included in the pack; we find separating all the hardware into piles makes it easier to be sure that everything is present and correct.
- Make sure you have the right tools. Allen keys are provided if required, but screw drivers and other tools are not. You'll find details of the tools you need at the beginning of the instructions.
- It's a good idea to build the unit in the room where you are going to be using it, to avoid the need to move it after it's been assembled.
- Do not throw away any packing materials until assembly is complete, just in case you accidentally discard smaller parts and hardware.

### **Safety Warnings:**

- Adult assembly required.
- Unassembled product contains small parts which may present a choking hazard.
- Children should be kept away from the product during assembly to avoid any possible risk of injury.
- Assemble and use on a flat and level surface.
- **DO NOT** use power tools in the assembly of this product as there is a risk of over-tightening and consequently splitting of the wood.
- Check all fixtures and fittings regularly and tighten as necessary.
- Please retain these instructions for future reference.

### **Customer Service:**

- If you find that any components are missing or damaged, please do not begin assembly and do not use the item. Please contact GLTC Customer Services on **0344 848 6000** immediately.

### **Product Care:**

- Wipe clean using a soft damp cloth followed by a dry cloth.
- The painted/lacquered surface is resistant to staining if cleaned immediately, however please protect the surface from contact with ball point pen and indelible style felt markers as the ink is by nature permanent.
- Do **NOT** use cleaning products which contain ammonia, solvents or abrasive material.
- Do **NOT** expose the item to extremes of heat and humidity.

### **Could we do better?**

If there is anything you think could be improved in these instructions or in the assembly of this product we'd be grateful if you could let us know; we'll pass any helpful hints and tips on to other customers via our website and update the instructions.

All you need to do is drop us a line at [\*\*instructions@gltc.co.uk\*\*](mailto:instructions@gltc.co.uk)





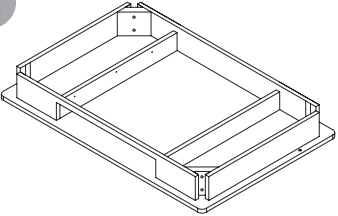
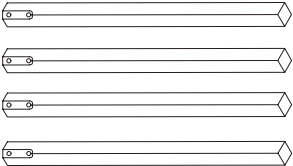
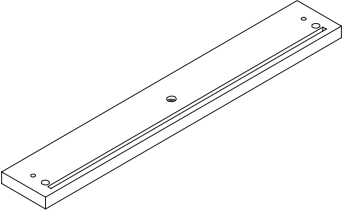
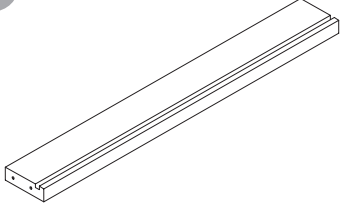
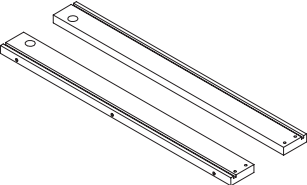
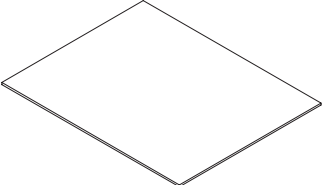
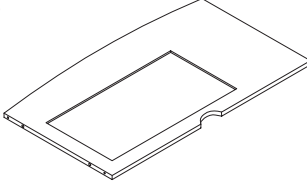
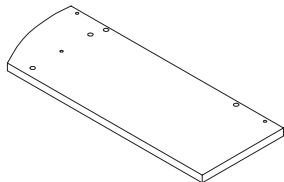

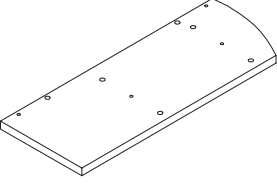
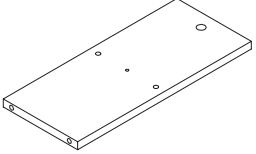
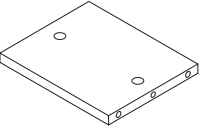
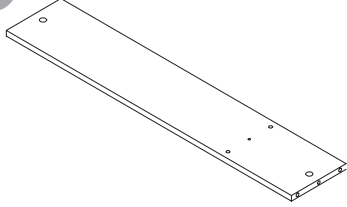

Thank you

## Component Check List

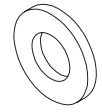

<p><b>A</b></p>  <p>1x Desk Top</p>	<p><b>B</b></p>  <p>4x Desk Legs</p>
<p><b>C</b></p>  <p>1x Drawer Front</p>	<p><b>D</b></p>  <p>1x Drawer Back</p>
<p><b>E</b></p>  <p>2x Drawer Sides</p>	<p><b>F</b></p>  <p>1x Drawer Base</p>
<p><b>G</b></p>  <p>1x Hutch: Back Panel</p>	<p><b>H</b></p>  <p>1x Hutch: Side Panel</p>

<p><b>I</b></p>  <p>1x Hutch: Side Panel</p>	<p><b>J</b></p>  <p>1x Hutch: Vertical Divider</p>
<p><b>K</b></p>  <p>1x Hutch: Small Shelf</p>	<p><b>L</b></p>  <p>1x Hutch: Top Shelf</p>

## Component Check List

<p>#1</p>  <p>13x Cam Dowel</p>	<p>#2</p>  <p>13x Cam Lock</p>
<p>#3</p>  <p>20x Wooden Dowel</p>	<p>#4</p>  <p>8x Bolt (57mm)</p>
<p>#5</p>  <p>7x Wood Screw (30mm)</p>	<p>#6</p>  <p>12x Wood Screw (14mm)</p>
<p>#7</p>  <p>8x Flat Washer</p>	<p>#8</p>  <p>8x Split Washer</p>

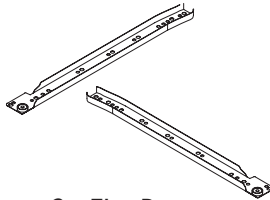
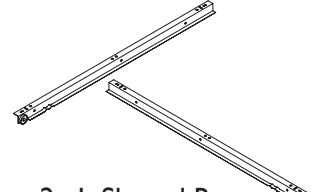
## Component Check List

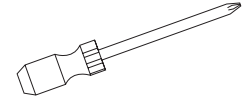
<p>#9</p>  <p>2x Flat Runner</p>	<p>#10</p>  <p>2x L-Shaped Runner</p>
<p>#11</p>  <p>1x Drawer Handle</p>	
<p>Your will need a Phillips Screwdriver</p>  <p>(not supplied)</p>	

### STEP 1:

Position the desk top on a protective surface like a rug or carpet as shown.

Attach the 2x flat runners (#9) to the inside of the desk. Ensure the runners are positioned with the wheels at the front opening of the desk and with the wheel on the upper edge of the runner as shown.

Use the holes shown to attach the runner to ensure the positioning is correct and use 3x screws (#6) to attach each runner.

Ensure the screws are fully inserted to ensure the drawer runs smoothly.

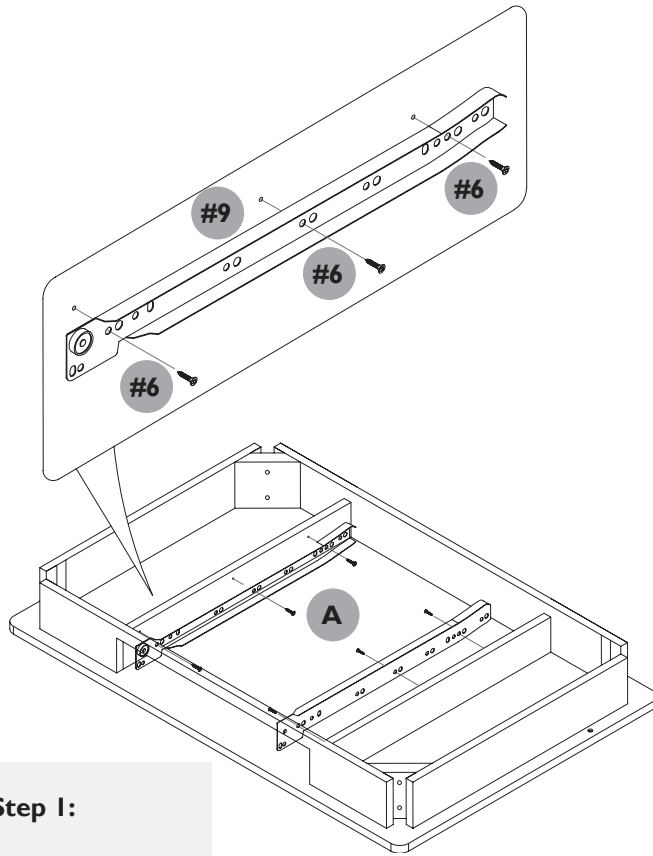

#### Hardware for Step 1:

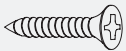

6x #6 Wood screws (14mm)

### STEP 2:

Prepare the hardware to attach the legs by taking 1x bolt (#4), thread on 1x split washer (#8) followed by 1x flat washer (#7). Prepare all remaining bolts.

Take one leg (B) and attach to the desk top using 2x of the pre-prepared bolts/washer sets.

**Please note:** When screwing in the pairs of bolts, for smoother insertion do not screw one individual bolt all the way in, but instead alternate securing each of the bolts until they are completely secure and as tight as they can possibly go.

Repeat with 3 remaining legs (B).

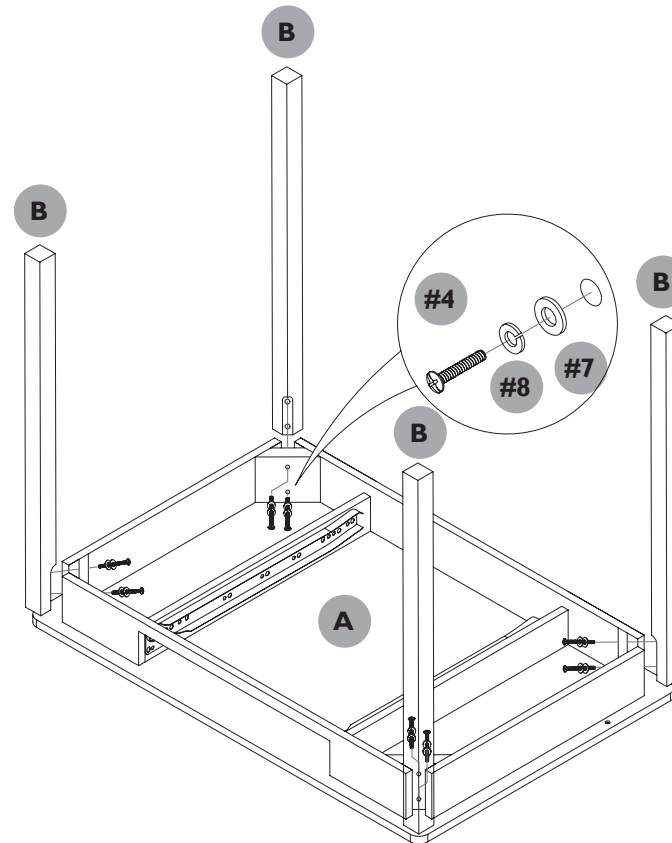

#### Hardware for Step 2:

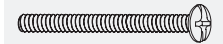

8x #4 Bolts (57mm)



8x #8 Split Washers



8x #7 Flat Washers

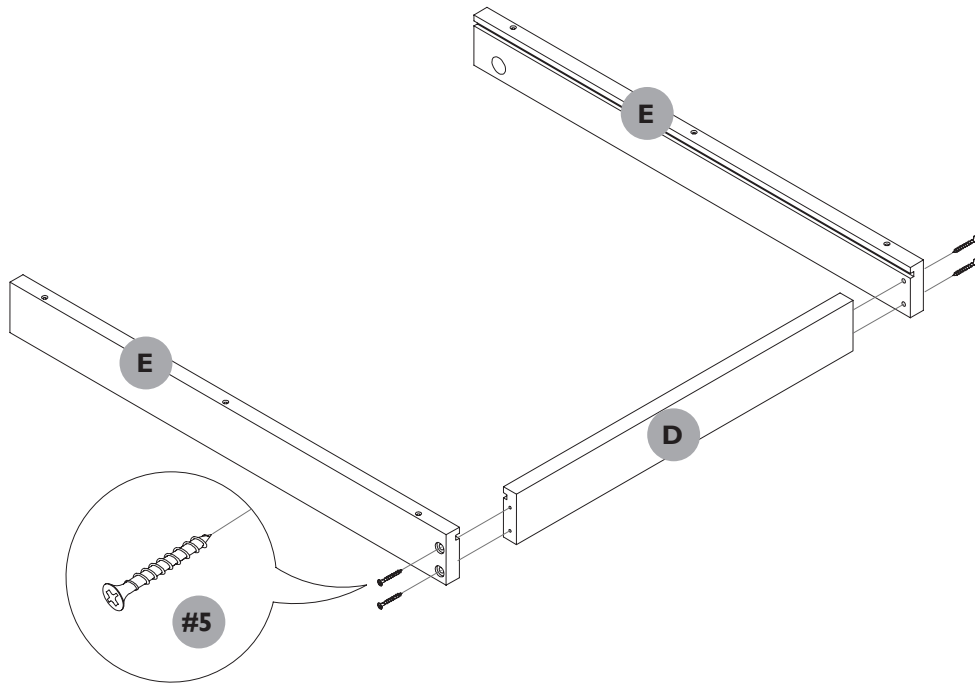

**Hardware for Step 3:**

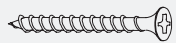

4x #5 Wood Screws  
(30mm)

**STEP 3:**

Take both of the drawer side panels (E) and position with drawer back panel (D) so that the grooves on the panels are all facing inwards and aligning. The small drill holes along the edges of the panels E should be visible and facing up.

Fix the side panels to the back panel using 2x #5 screws on BOTH sides.

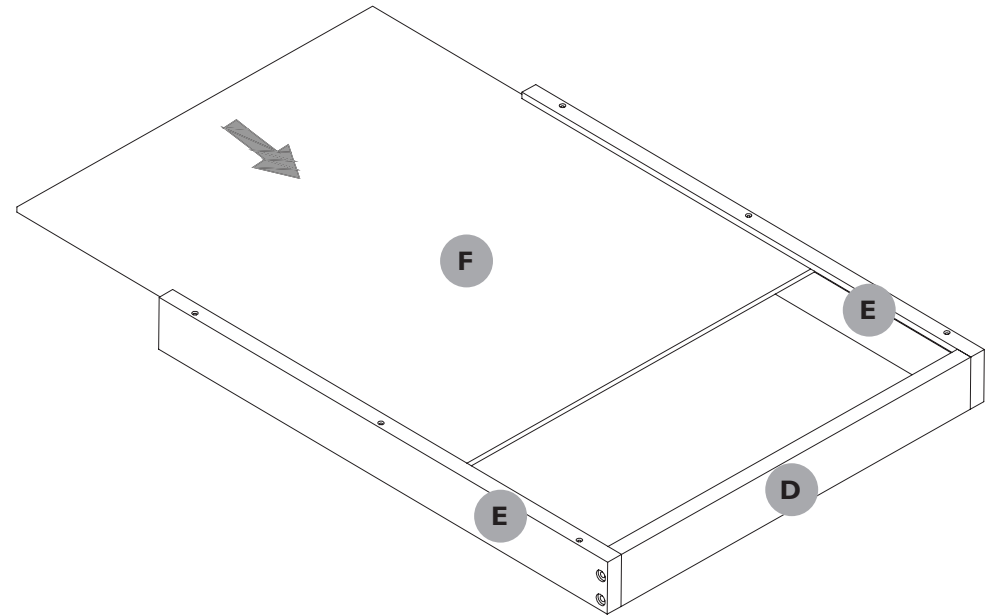

**STEP 4:**

Slide drawer base panel F into the grooves.

### STEP 5:

Take the drawer front panel C and insert 2x cam dowels (#1) into the 2 smaller holes on the ends of the panel. Insert 2x wooden dowels (#3) into the larger holes.

Attach the drawer handle (#11) using 1x screw (#5).

#### Hardware for Step 5:

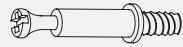

2x #1 Cam Dowels



2x #3 Wooden Dowels



1x #11 Handle

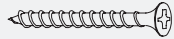

1x #5 Wood Screw  
(30mm)

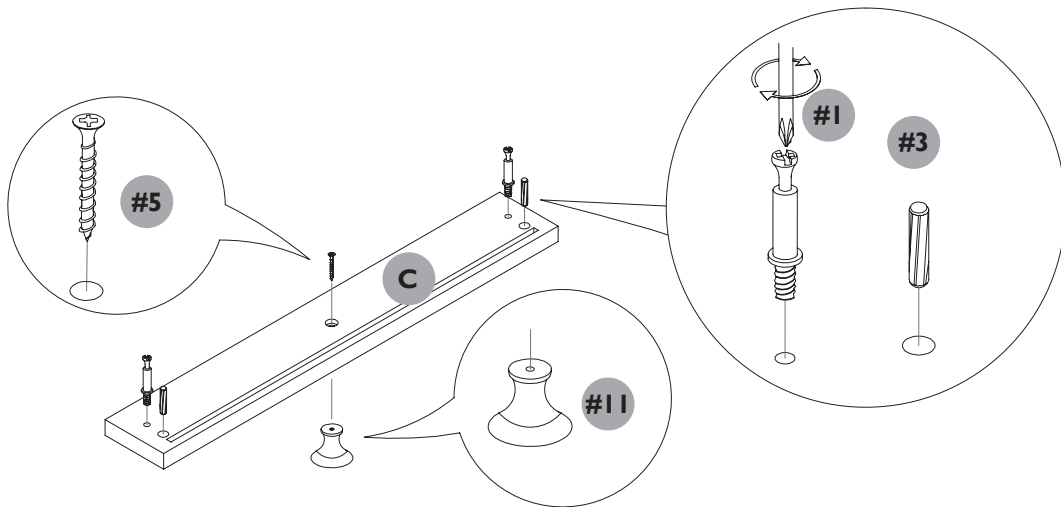

### Using Cam Locks:

When inserting into the panel, ensure that each cam lock's arrow is pointing towards the drill hole on the side edge of the panel & the dowel that it will be receiving.

When the panels are in the connected position, using a screwdriver, turn the cam lock in a clockwise direction to lock and secure.

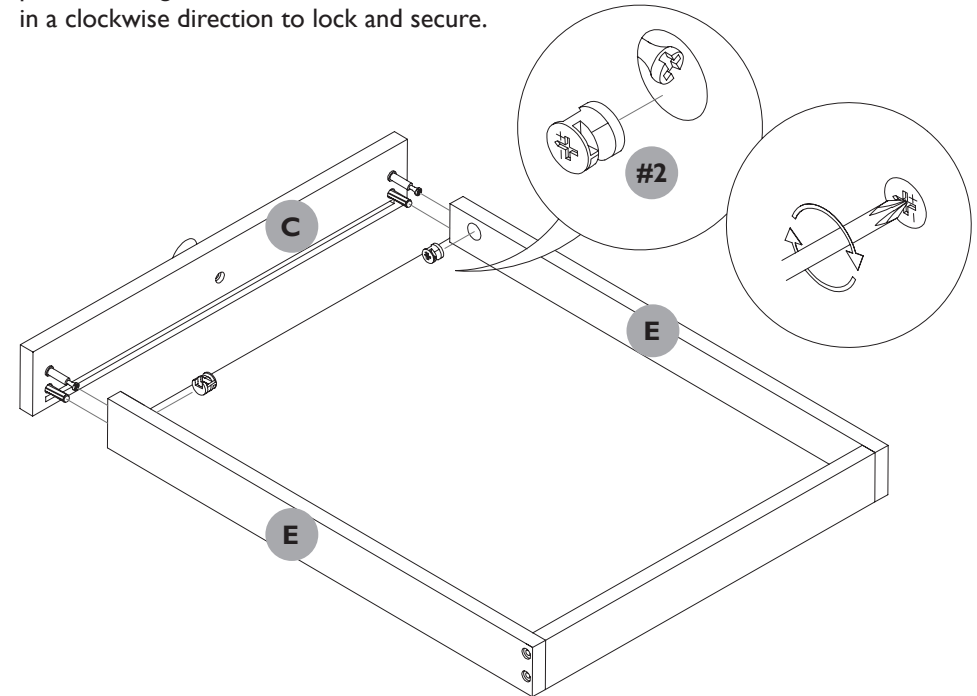

#### Hardware for Step 6:



2x #2 Cam Locks

### STEP 6:

Attach the drawer front to the drawer box. Insert 2x #2 Cam locks into the large holes on the side panels and turn clockwise to secure in place.

### STEP 7:

Turn the drawer over so the small holes on the edges of the side panels are visible.

Position 2x L-Shaped drawer runners (#10) on each side ensuring the wheel is at the back of the drawer.

Secure both runners to the drawer using 6x screws (#6).

#### Hardware for Step 7:

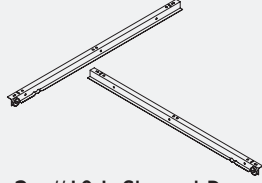

2x #10 L-Shaped Runners

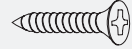

6x #6 Wood Screws (14mm)

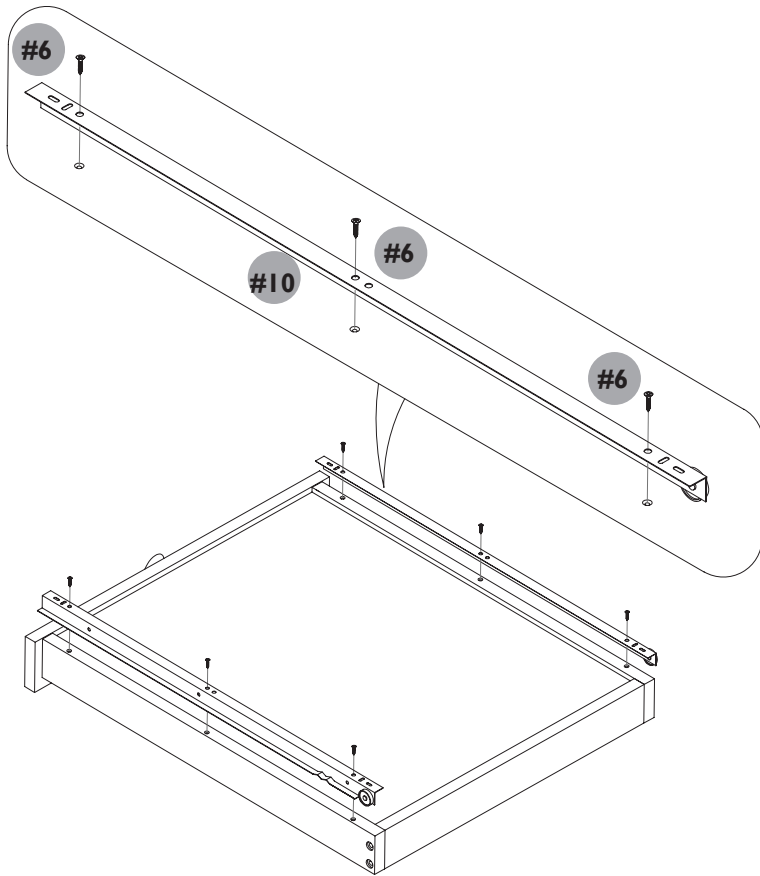

### STEP 8:

Carefully stand the desk up on its legs and insert the drawer.

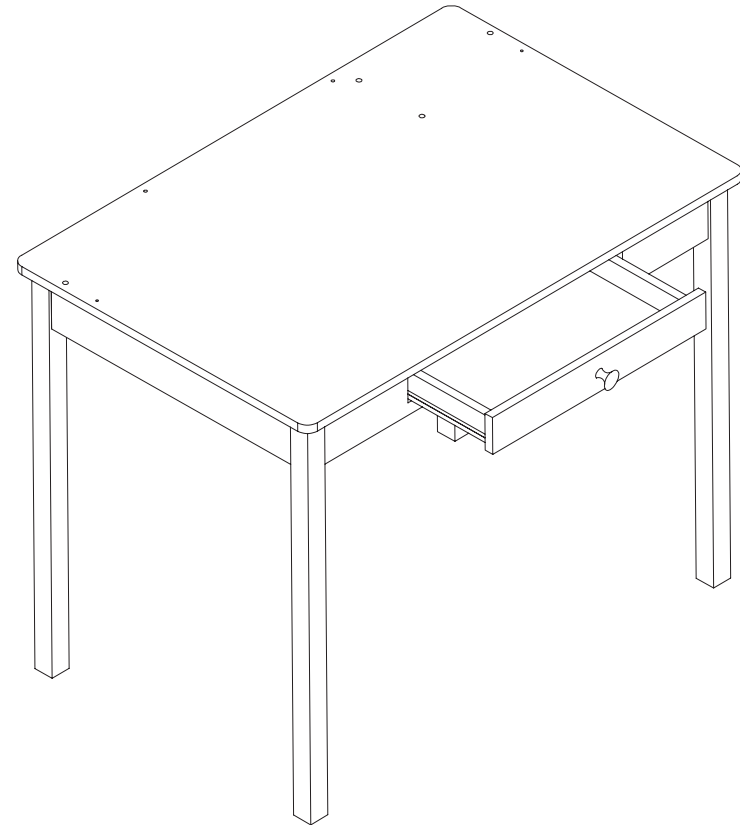



**STEP 9:**

Prepare both hutch side panels (H & I) and insert the cam dowel and wooden dowel hardware into the pre-drilled holes as shown.

Cam dowels to go in the smaller holes, wooden dowels in the larger holes.

**Hardware for Step 9:**

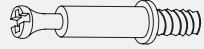

7x #1 Cam Dowels



10x #3 Wooden Dowels

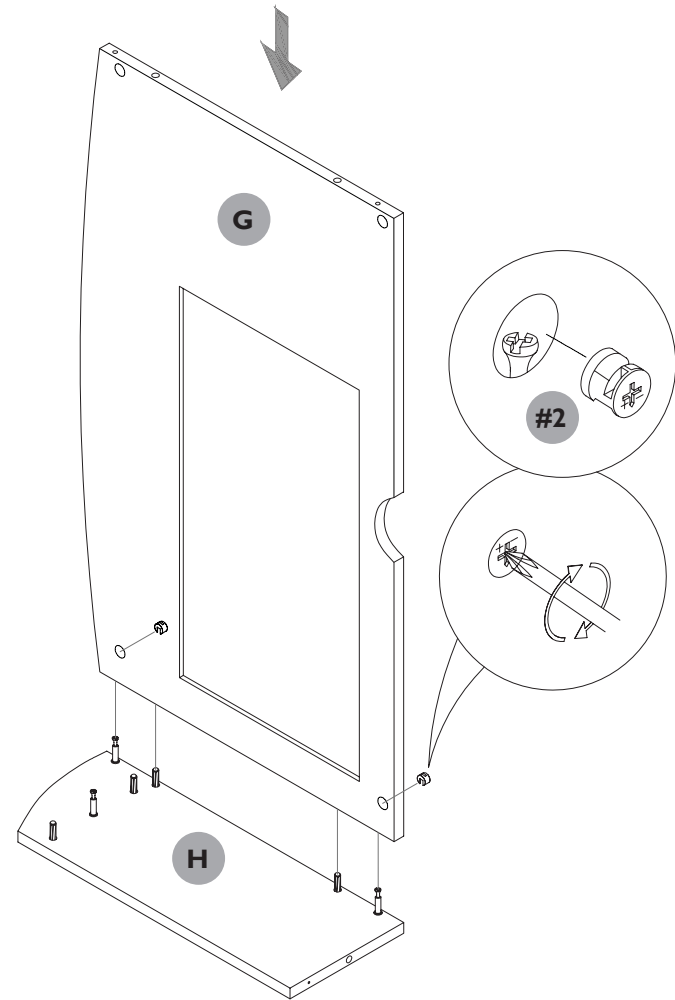
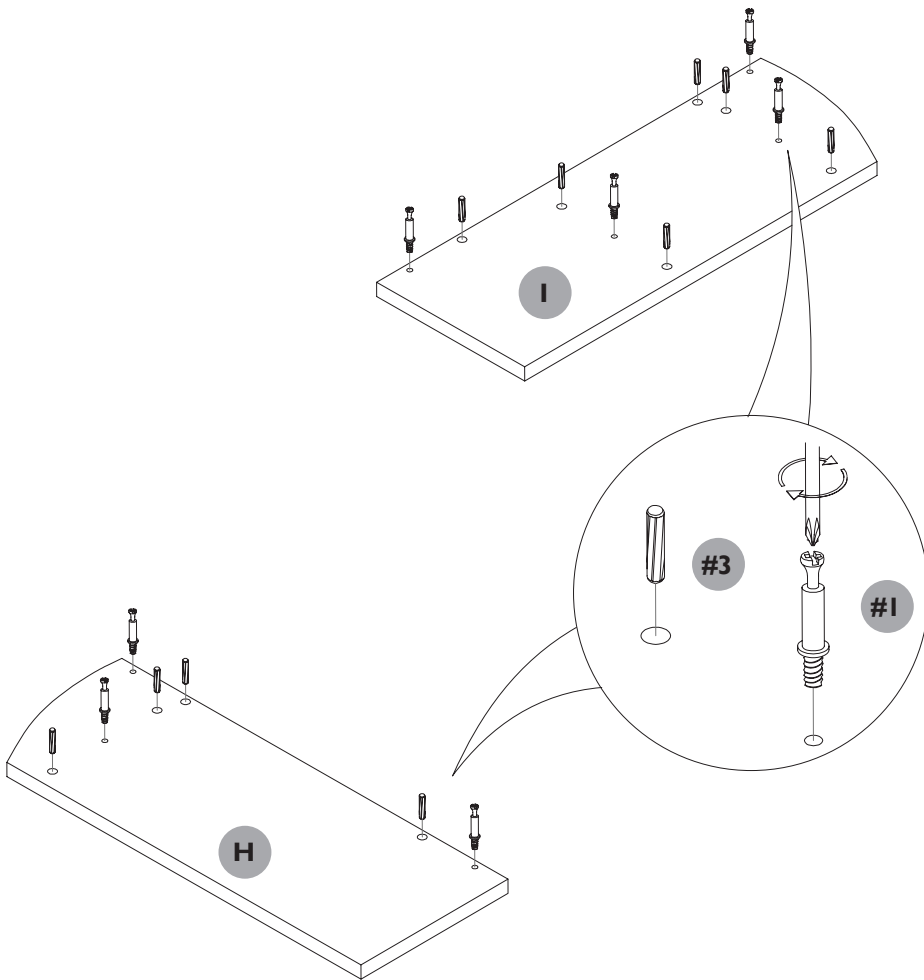

**Hardware for Step 10:**



2x #2 Cam Locks

**STEP 10:**

Position side panel H on the floor and push hutch back panel (G) into position onto the hardware as shown.

Keep the back panel supported and insert 2x cam locks (#2) into the drill holes on the back of panel G, turning clockwise to secure.

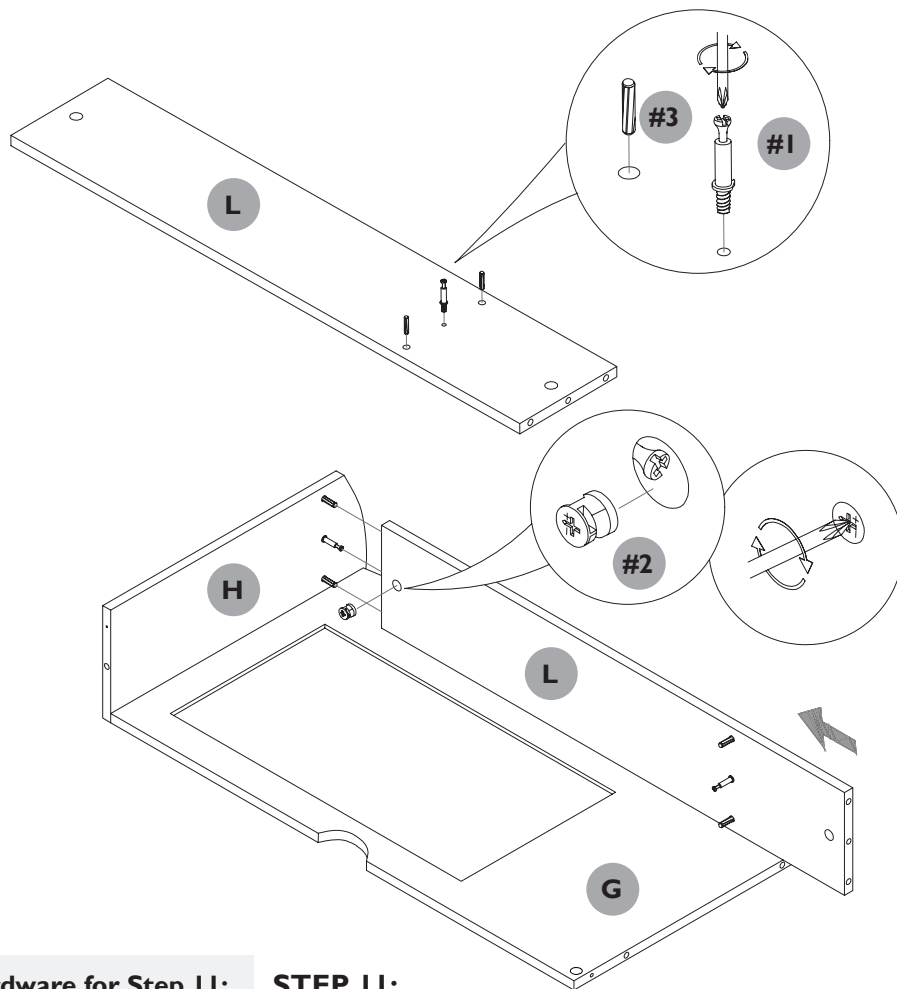

**Hardware for Step 11:**



1x #1 Cam Dowels



2x #3 Wooden Dowels



1x #2 Cam Lock

**STEP 11:**

Take the upper shelf panel (L) and insert 2x wooden dowels (#3) and 1x cam dowel (#1) into the holes shown.

Then fix panel L onto the hutch back/side panels as shown.

Insert 1x cam lock (#2) into the large hole by the side panel and turn clockwise to secure.

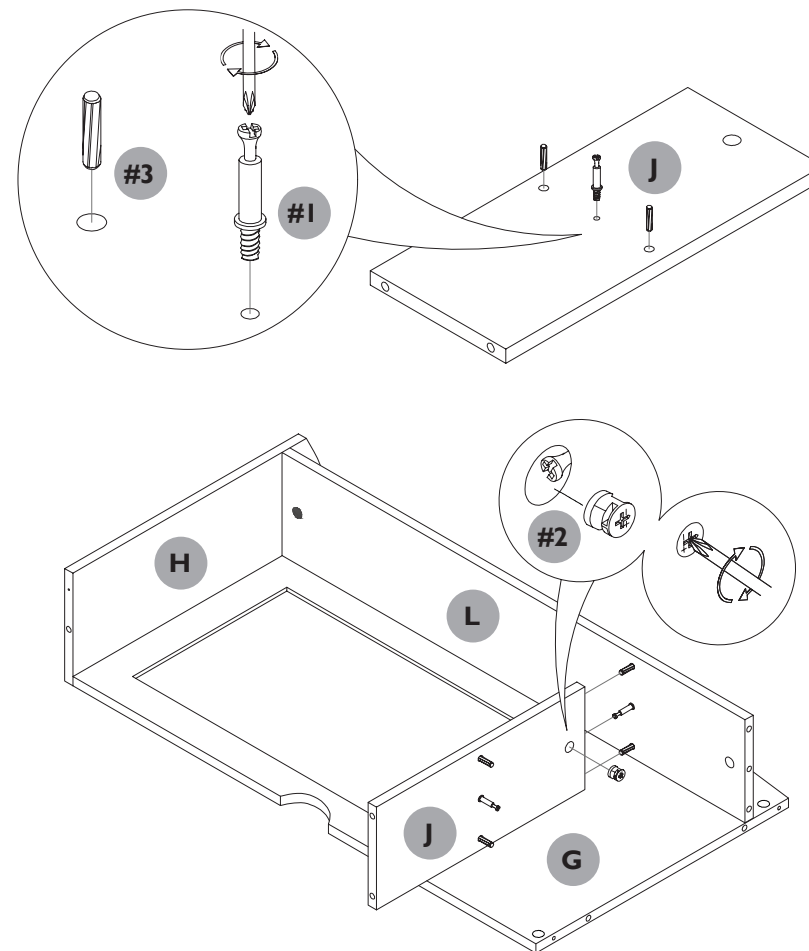

**Hardware for Step 12:**

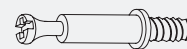

1x #1 Cam Dowels



2x #3 Wooden Dowels



1x #2 Cam Lock

**STEP 12:**

Take vertical divider panel (J) and insert 2x wooden dowels (#3) and 1x cam dowel (#1) into the holes shown.

Then fix panel J onto panel L as shown. Insert 1x cam lock (#2) into the top of panel J and turn clockwise to secure.

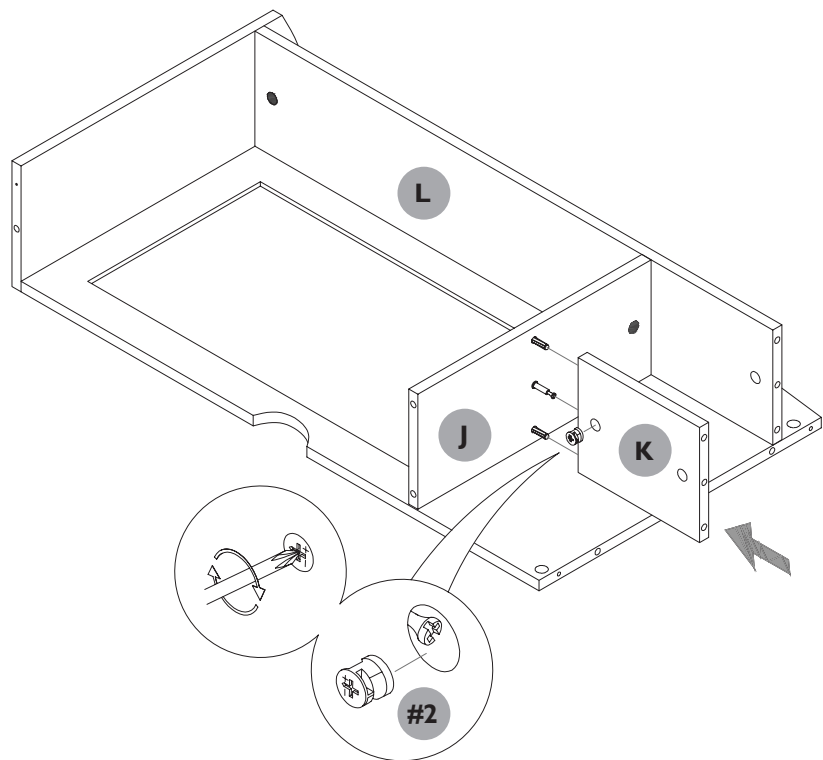

**Hardware for Step 13:**



**1x #2 Cam Lock**

**STEP 13:**

Take shelf panel K and push onto the hardware on panel J. Ensure the large drill holes are facing down towards the straight edge of the hutch.

Insert 1x cam lock (#2) into the hole next to panel J and turn clockwise to secure.

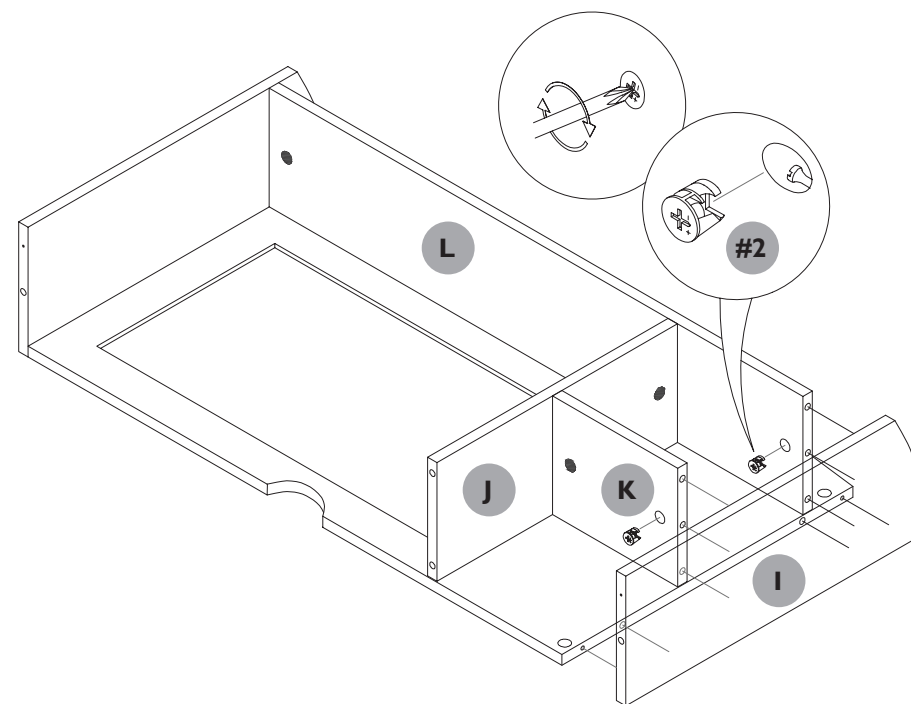

**Hardware for Step 14:**



**2x #2 Cam Lock**

**STEP 14:**

Take hutch side panel (I) and push onto the end of the unit as shown.

When in aligned with the hardware and in position, insert 2x cam locks (#2) into the remaining large drill holes on the undersides of the shelves and turn clockwise to secure.

**STEP 15:**

Carefully stand the hutch unit up and insert 2x cam locks (#2) into the holes on the side of the back panel and turn clockwise to secure.

**Hardware for Step 15:**



**2x #2 Cam Lock**

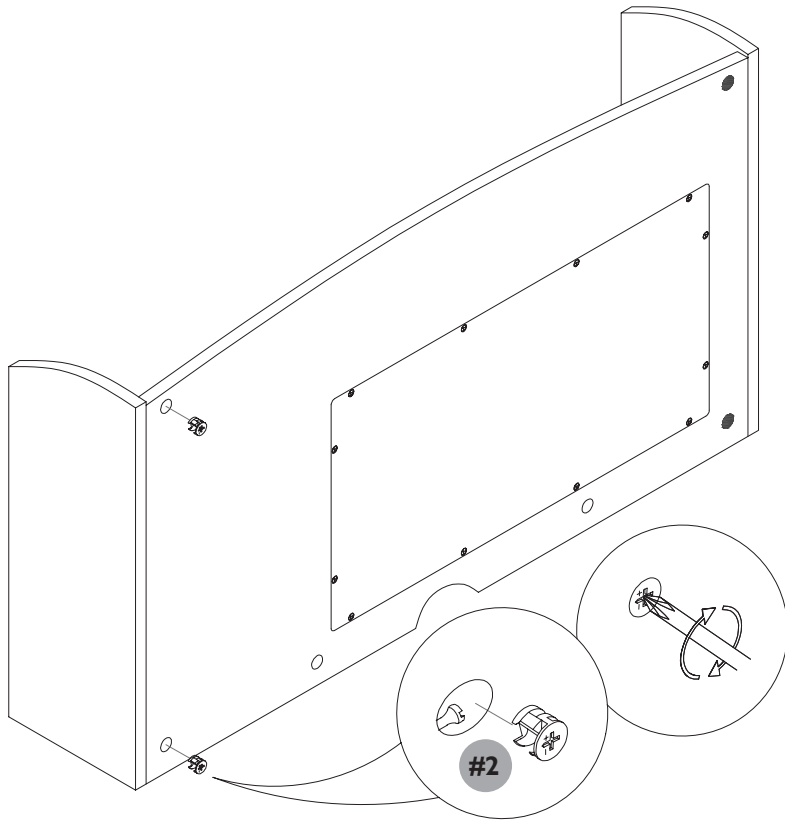

Your hutch unit is now complete.

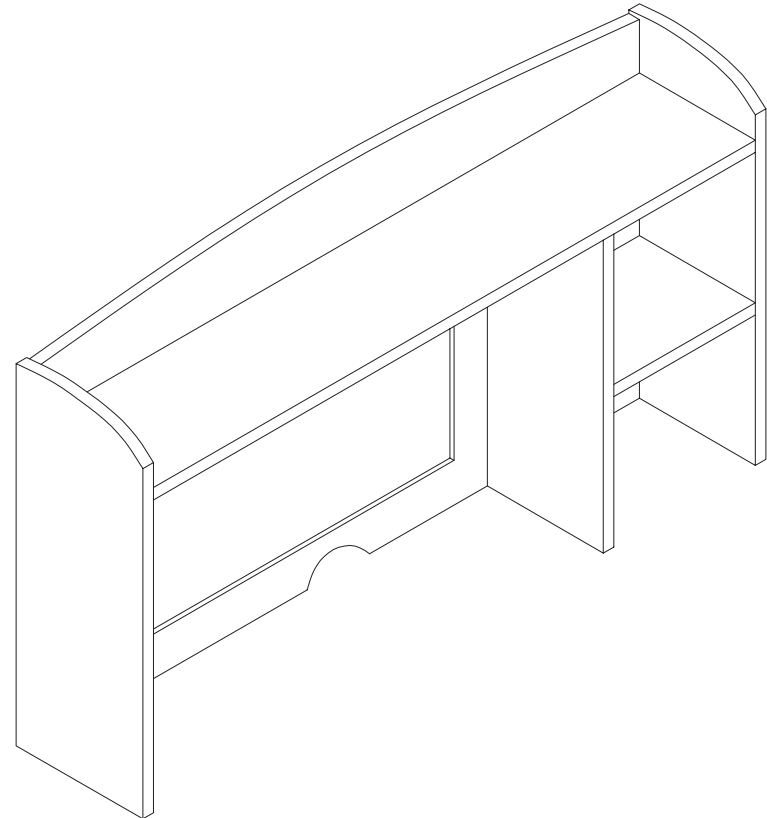

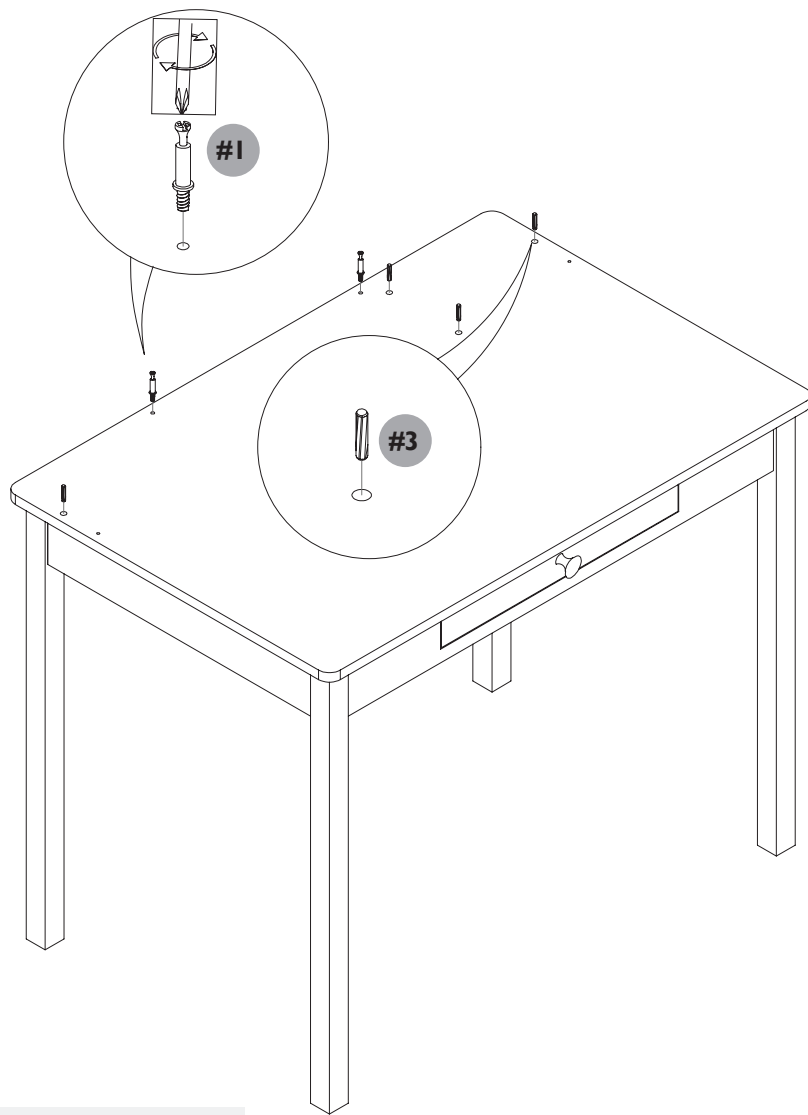

**Hardware for Step 16:**

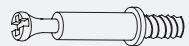

2x #1 Cam Dowel



4x #3 Wooden Dowel

**STEP 16:**

Return to the Desk and insert 2x cam dowels (#1) into the pre-drilled holes on the back edge of the desk top.

Insert 4x wooden dowels (#3) into the remaining holes.

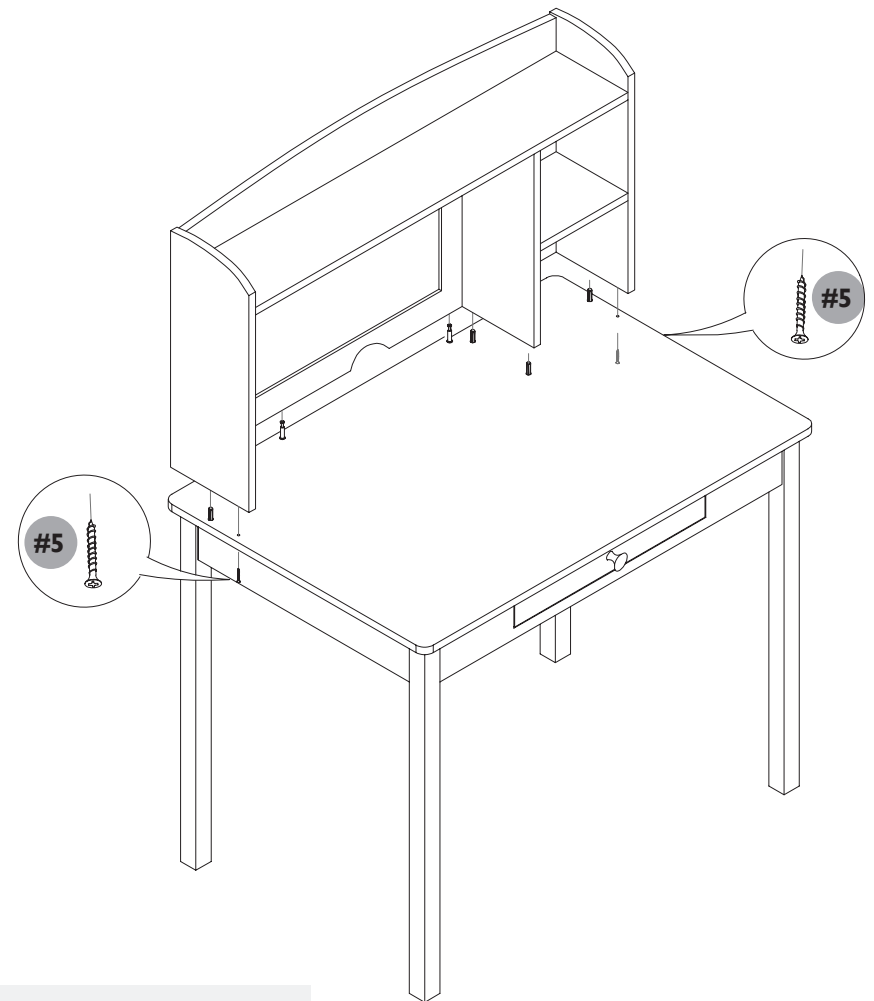

**Hardware for Step 17:**

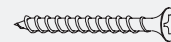

2x #5 Wooden Screws (30mm)

**STEP 17:**

With the help of a second person, carefully position the hutch onto the desktop - aligning the hardware on the desktop with the holes on the underside of the hutch.

Please ensure the hutch is in a straight position before going to the next step.

When in position insert 1x screw (#5) through the underside of the desktop edge into the hutch. Repeat on the other side.

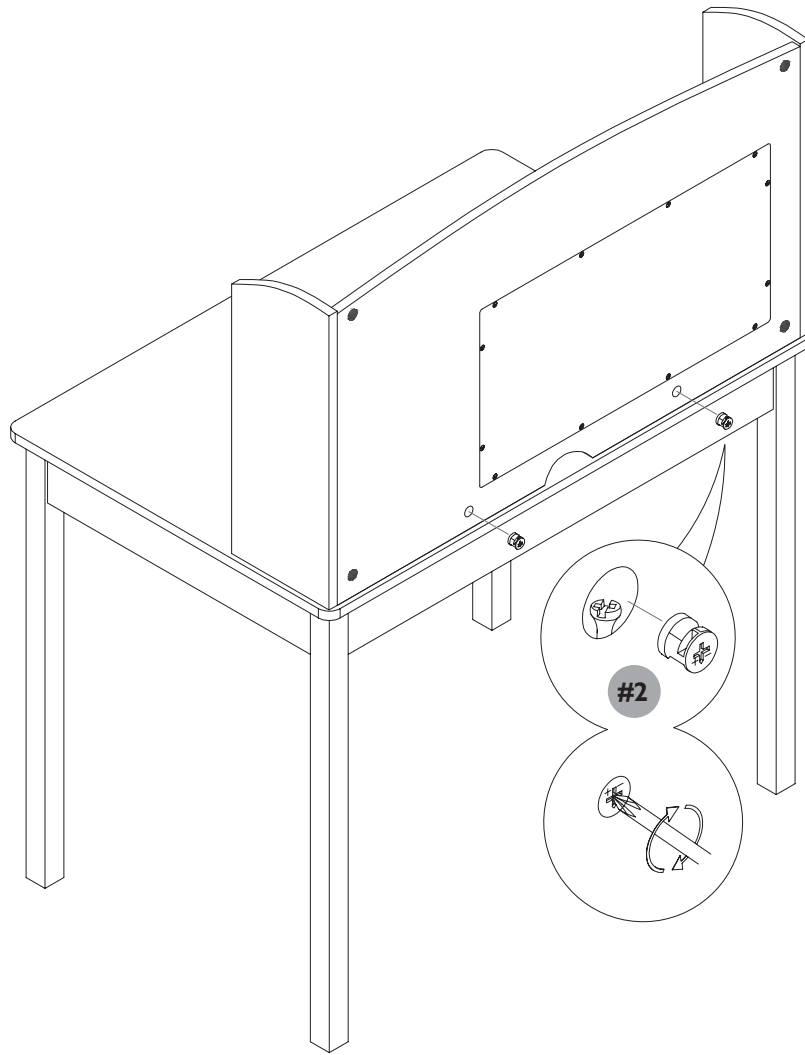

Your Desk is now ready to use.

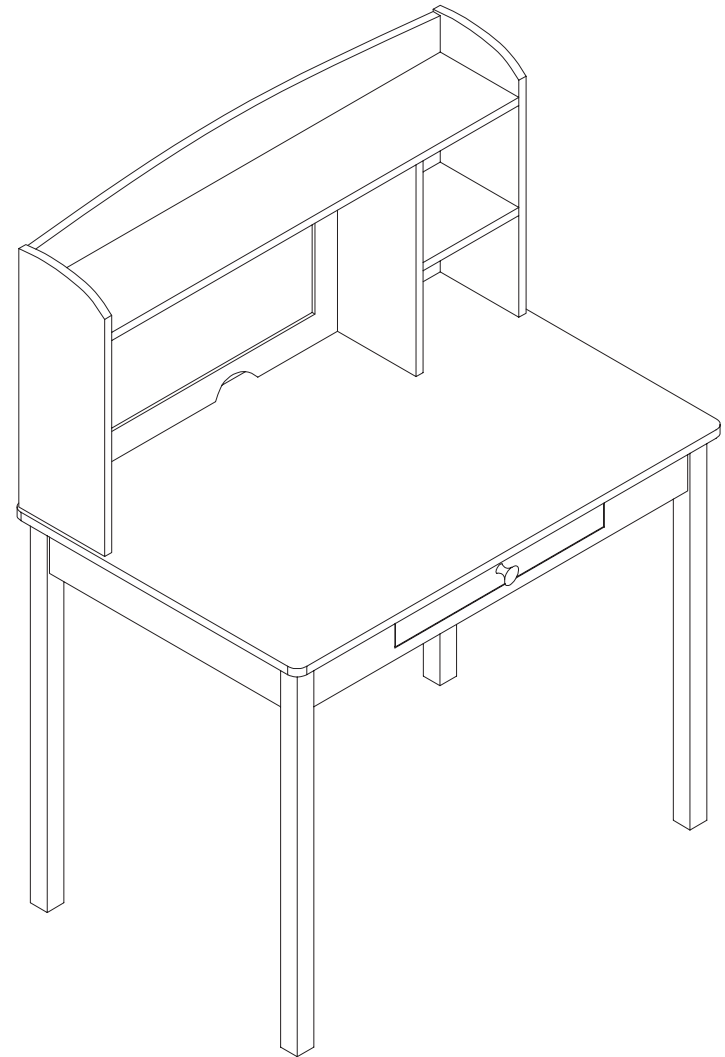

**Hardware for Step 18:**



**2x #2 Cam Locks**

**STEP 18:**

Finally, insert 2x cam locks (#2) into the remaining holes on the back of the hutch. Turn clockwise to secure.