

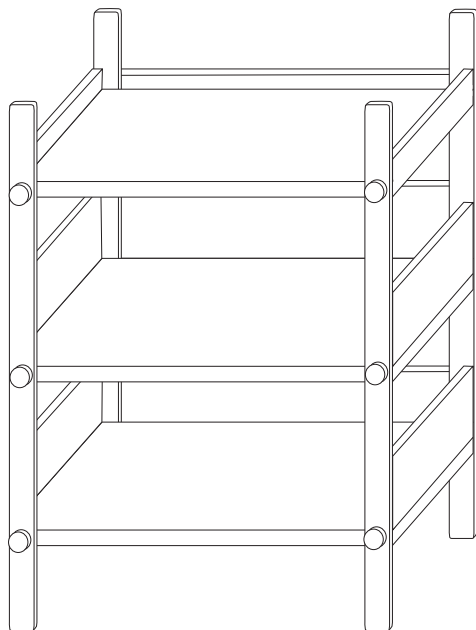

gltc.co.uk

## Buttons Medium Bookcase



Assembly Difficulty



easy - medium - hard



one-person job

V2

03/02/2020

**Thank you for shopping with GLTC, we hope you enjoy having this product in your home.**

We know assembling furniture, toys or accessories is not everyone's favourite way to spend their time, so we've tried to make assembling this item as quick and painless as possible.

Hopefully our efforts will have been worthwhile and you'll sail through the whole process. But if it all feels a bit too much like hard work, then we do have an assembly company we can recommend: the Flatpack Construction Company offers a nationwide service and can be contacted on **0843 289 4951** or **www.flatpackconstruction.co.uk**.

### **A few important pointers before you start:**

- Please read the instructions right through before you start, and check that all the components have been included in the pack; we find separating all the hardware into piles makes it easier to be sure that everything is present and correct.
- Make sure you have the right tools. Allen keys are provided if required, but screw drivers and other tools are not. You'll find details of the tools you need at the beginning of the instructions.
- Do not throw away any packing materials until assembly is complete, just in case you accidentally discard smaller parts or hardware.

### **Safety Warnings:**

- Warning! Not suitable for children under 3 years due to small parts which may become detached and present a choking hazard.
- Assembly by a competent adult is required.
- Unassembled product contain small parts which may pose a choking hazard to young children.
- During assembly children should be kept away from the product due to possible risk of injury.
- Assemble and use on a flat and level surface.
- **WARNING! FURNITURE TIPPING RISK.** Serious or fatal crushing injuries can occur from furniture tipping over. Ensure you secure this furniture product to the wall before you use it, using the kit provided. If you have not received an anti-tip kit with your product please contact Customer services.
- To avoid possible injury from tipping - **DO NOT** allow children to step or climb on the product.
- Maximum shelf weight load 10kg. Do not overload.
- Check all fixtures and fittings regularly and tighten as necessary.
- Remove all packaging before allowing your child to use the product.
- Please retain for future reference.

### **Customer Service:**

- If you find that any components are missing or damaged, please do not begin assembly and do not use the item. Please contact GLTC Customer Services on **0344 848 6000** immediately.
- We do stock spare hardware packs at our warehouse, so we should be able to send you a replacement pack immediately if required.

### **Product Care:**

- Wipe clean using a soft damp cloth followed by a dry cloth.
- Do **NOT** use cleaning products which contain ammonia, solvents or abrasive material.
- Do **NOT** expose the item to extremes of heat and humidity.
- Regularly check all fastenings, fixtures and fittings to ensure that they properly tightened.





### **Could we do better?**



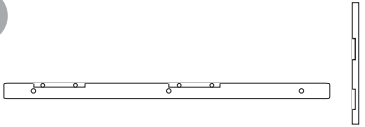
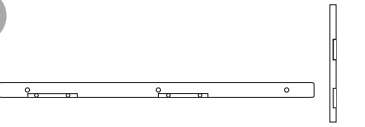
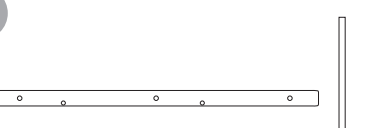
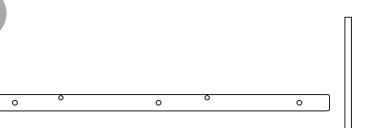
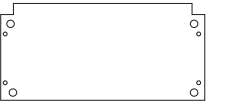

If there is anything you think could be improved in these instructions or in the assembly of this product we'd be grateful if you could let us know; we'll pass any helpful hints and tips on to other customers via our website and update the instructions.

All you need to do is drop us a line at [instructions@gltc.co.uk](mailto:instructions@gltc.co.uk)

Thank you

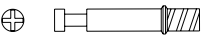
# Component Check List

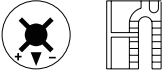
<p><b>A</b></p>  <p>1x Back leg</p>	<p><b>B</b></p>  <p>1x Back leg</p>
<p><b>C</b></p>  <p>1x Front leg</p>	<p><b>D</b></p>  <p>1x Front leg</p>
<p><b>E</b></p>  <p>2x Lower shelves</p>	<p><b>F</b></p>  <p>1x Top shelf</p>
<p><b>G</b></p>  <p>4x Shelf side panels</p>	<p><b>H</b></p>  <p>2x Back panels</p>

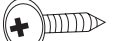
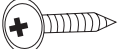
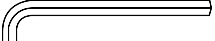
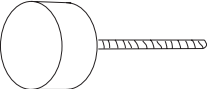
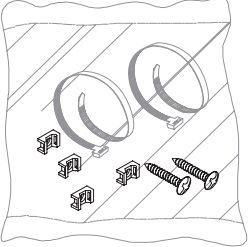
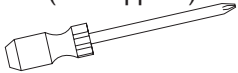
<p><b>#1</b></p>  <p>8x Cam Dowels</p>	<p><b>#2</b></p>  <p>8x Flat Headed Screws 40mmL</p>
<p><b>#3</b></p>  <p>8x Cam Locks</p>	<p><b>#4</b></p>  <p>6x Bolts 53mmL</p>
<p><b>#5</b></p>  <p>12x Barrel Nuts</p>	<p><b>#6</b></p>  <p>8x Domed Screws 10mmL</p>
<p><b>#7</b></p>  <p>4x Domed Screws 16mmL</p>	<p><b>#8</b></p>  <p>1x Allen Key</p>
<p><b>#9</b></p>  <p>6x Button Bolt</p>	<p><b>#10</b></p>  <p>1x Anti-Tip Strap Kit</p>
<p>You will need (not supplied)</p>  <p>Phillips Head Screwdriver</p>	

### STEP 1:

Prepare back leg panels A and B by inserting 4x cam dowels (#1) into the holes as shown.

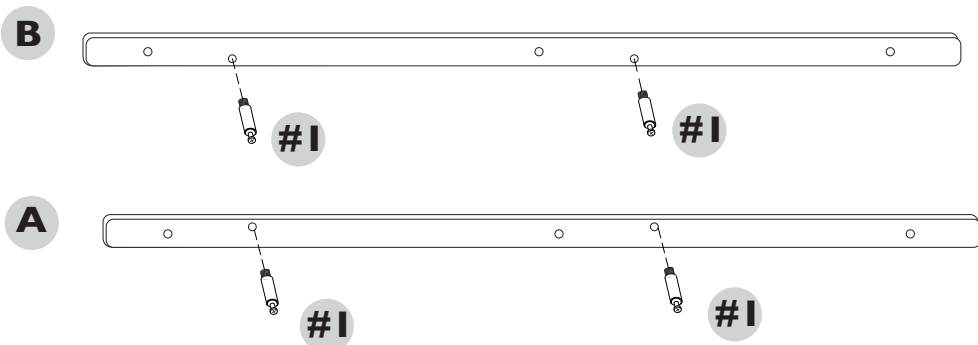

#### Hardware for Step 1:

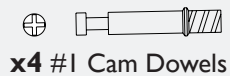

### STEP 2:

Attach 2x side panels (G) to shelf panel E with 4x flat headed screws (#2).

Repeat for the remaining E and G panels.

These are the lower two shelf components.

#### Note:

The large drill holes on the side panels to face inwards.

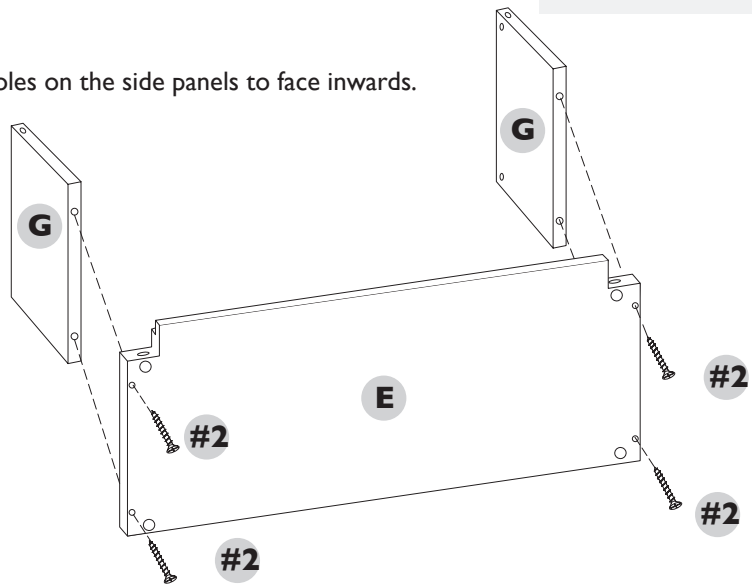

#### Hardware for Step 2:

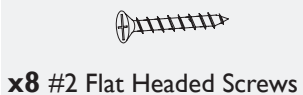

### STEP 3:

Lay the two shelf components on the floor with the grooved edge facing upward. This is the back. As shown position back leg panels A and B over the constructed shelves with the grooves facing up and aligned with the shelves.

Push panels A and B into position. Insert 4 x cam locks (#3) into the large drill holes on the inside of each G panel, turn clockwise to tighten.

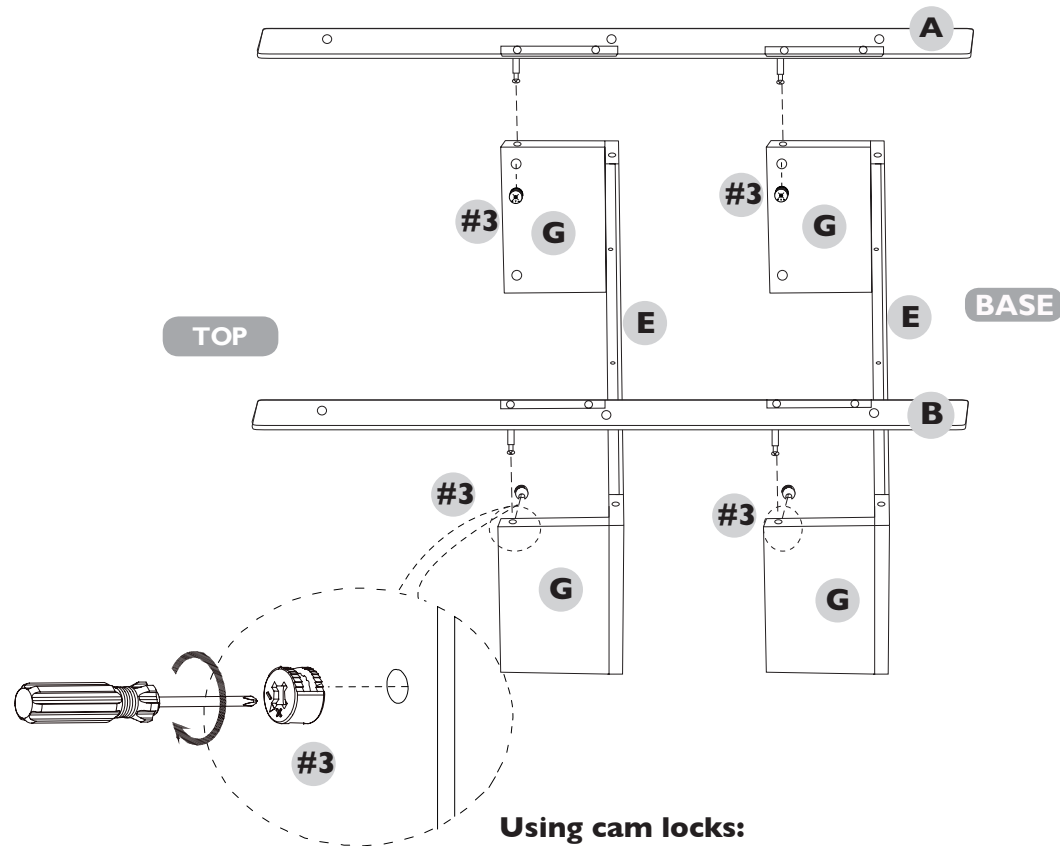

#### Using cam locks:

When inserting into the panel, ensure that each cam lock's arrow is pointing towards the drill hole on the side edge of the panel & the dowel that it will be receiving.

When the panels are in the connected position, using a screwdriver, turn the cam lock in a clockwise direction to lock and secure.

#### Hardware for Step 3:

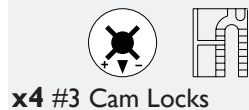



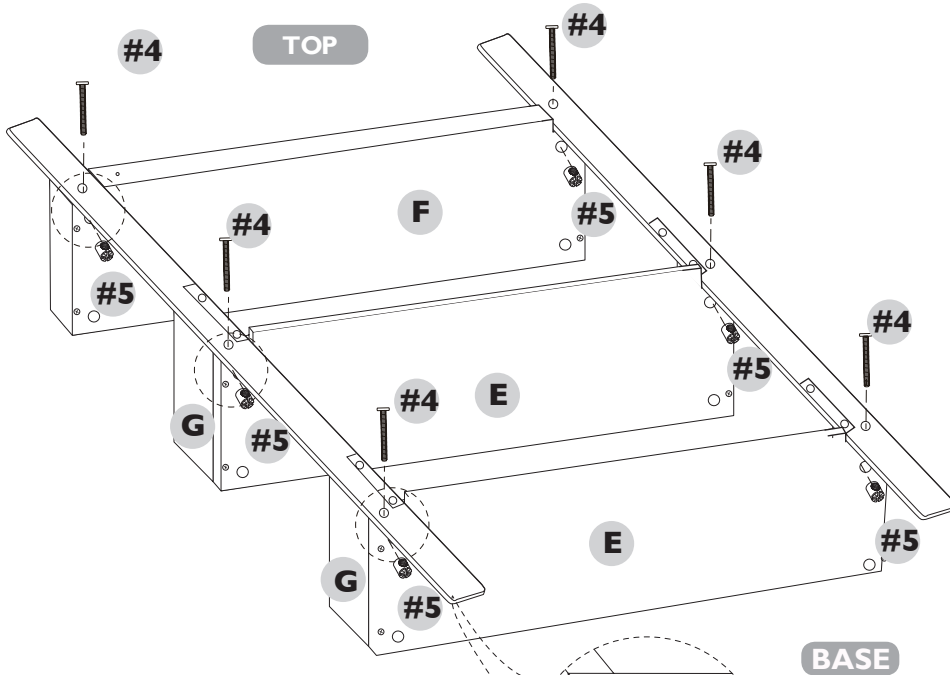

### STEP 4:

Position top shelf panel F to sit under the two remaining drill holes of the leg panels. Prepare the shelf panels by inserting 6x barrel nuts (#5) into the holes as shown. Secure shelves using 6x bolts (#4), tighten bolts using allen key provided.

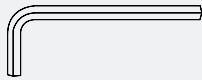

#### Hardware for Step 4:

-    
x6 #5 Barrel Nuts
-    
x6 #4 Bolts
-   
x1 #8 Allen Key

### STEP 5:

Position the 2x back panel Hs in place as shown and align the drill holes with those along the grooved edge as shown.

Fix in place to leg panel A and B with 8x shorter domed screws (#6). Then finish fixing to the two shelf panel Es with 4x longer domed screws (#7).

#### Note:

This step uses hardware that looks the same, but are different lengths. Ensure you use the hardware correctly or you risk damaging the unit.

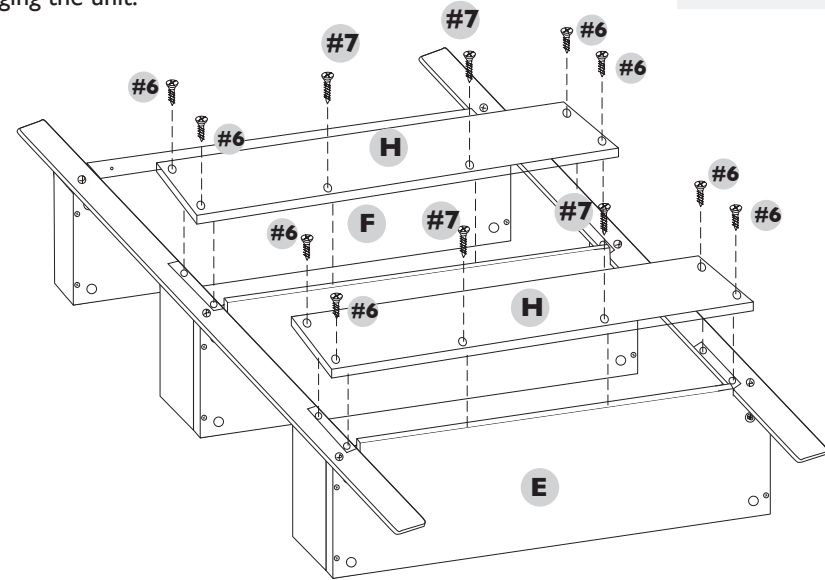

#### Hardware for Step 5:

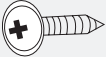
-   
x8 #6 10mm Domed Screws
-   
x4 #7 16mm Domed Screws

### STEP 6:

Prepare front leg panels C and D by inserting 4x cam dowels (#1) into the holes as shown.

#### Hardware for Step 6:

-   
x4 #1 Cam Dowels

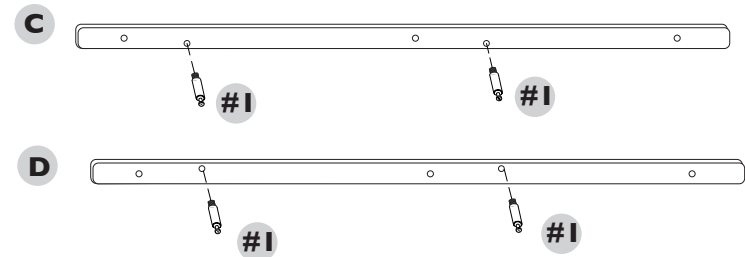

## STEP 7:

Carefully turn the unit over.

Push front leg panels C and D into position as shown. Insert 4 x cam locks (#3) into the large drill holes on the inside of each G panel, turn clockwise to tighten.

Prepare shelf panels by inserting 6x barrel nuts (#5) into the holes as shown.

Secure shelves to panels C and D using 6x button bolts (#9).

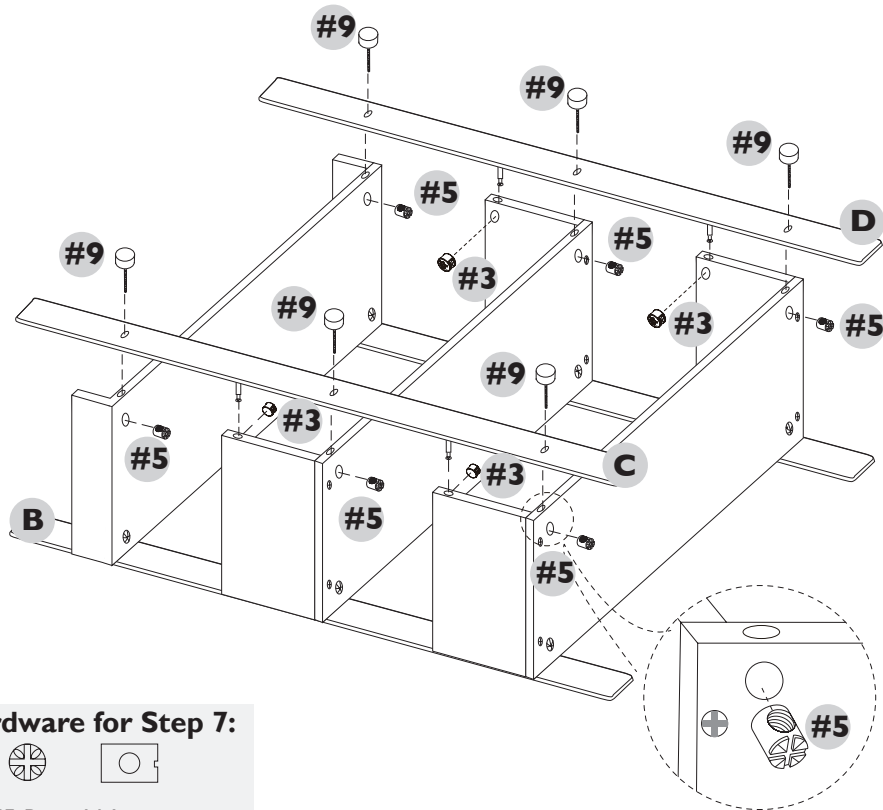

### Hardware for Step 7:



x6 #5 Barrel Nuts



x4 #3 Cam Locks

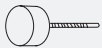

x6 #9 Button Bolts

### Hardware for Step 8:

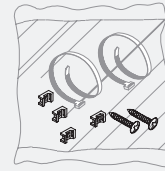

x1 #10 Anti Tip Strap Kit

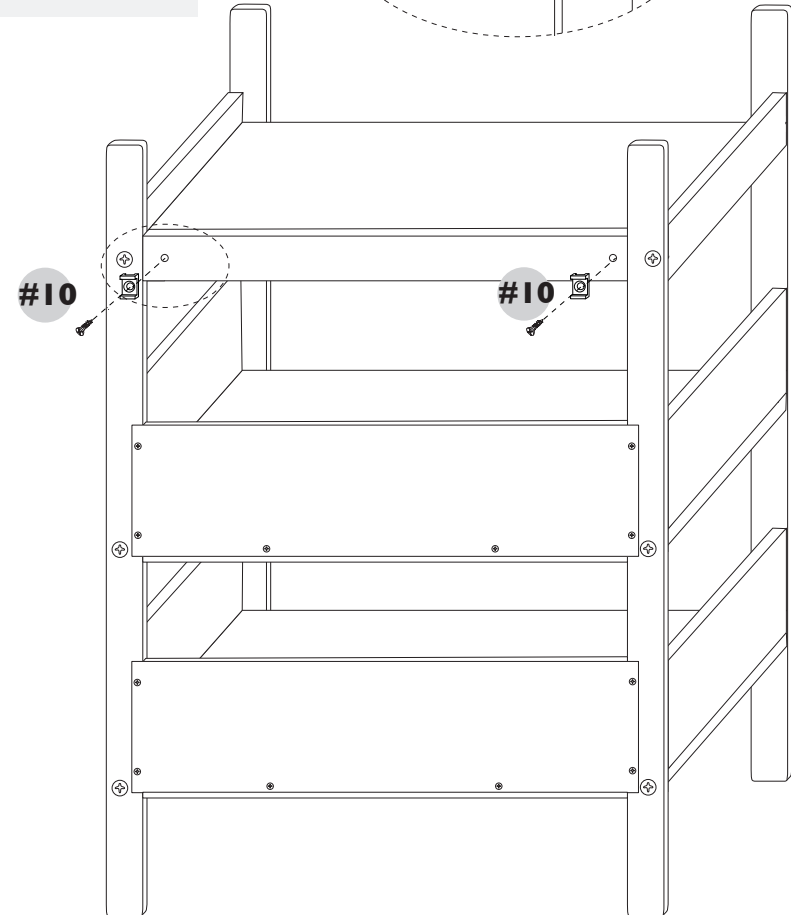
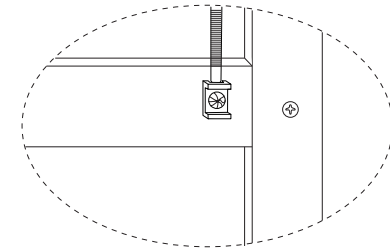

## STEP 8:

Before you use your unit, we strongly advise that you use the anti-tip kit (included) to secure this product to the wall, especially if young children have access to the unit.