



IMI CORNELIUS INC.  
One Cornelius Place  
Anoka, MN. 55303-6234  
Telephone 1-800-238-3600  
Facsimile 1-800-258-0255

[www.cornelius.com](http://www.cornelius.com)

## ILLUSTRATED PARTS LIST

---

### XTREME ICE MAKER (630-830-1030 SERIES)

#### MODEL NO.

631806001  
631806002  
631806003  
631806004  
631806020  
631806040  
631806041  
631808001  
631808002  
631808003  
631808004  
631808020  
631810001  
631810002  
631810003  
631810004  
631810020

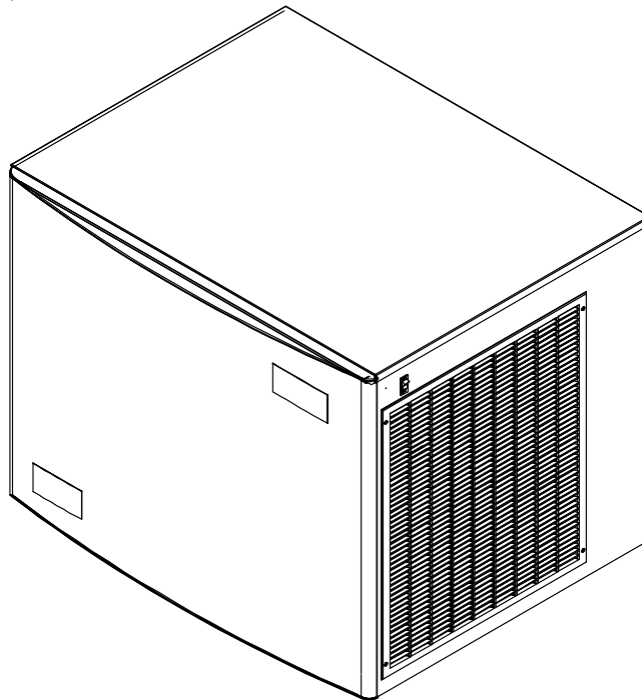



IMI CORNELIUS INC.  
 One Cornelius Place  
 Anoka, MN. 55303-6234  
 Telephone 1-800-238-3600  
 Facsimile 1-800-258-0255

www.cornelius.com

## ILLUSTRATED PARTS LIST

### XTREME ICE MAKER (630-830-1030 SERIES)

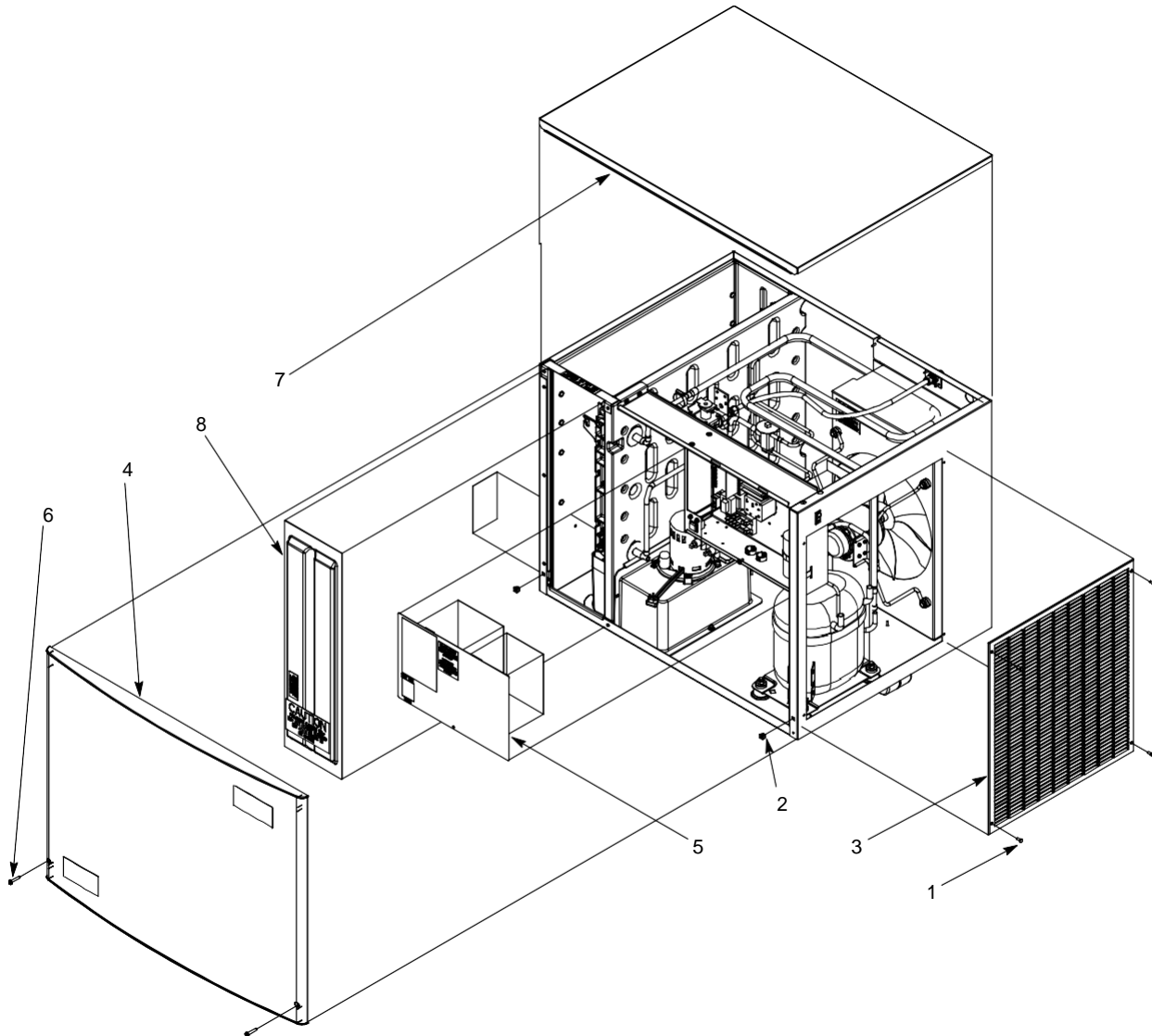

FIGURE 1. GENERAL ASSEMBLY (AIR CONDENSER SHOWN)

Item No.	Part No.	Name
1	161168006	Screw TC 8-32 HX 12
	161090000	Screw TC 8-32 HXSL 10 (Marine)
2	164510000	Nut Grommet
3	166194001	Grille Plstc Blk
	630200510	Panel Accs RH Side (Marine)
4	631500136	Kit Svc Front Panel Asy (See Figure 13)
	167979015	Panel Fnt (Marine) (See Figure 13)

Item No.	Part No.	Name
5	630201041	Cover Elec Box
	630201247	Cover Elec Box (Marine)
6	318308000	Screw TR 10-32 PAPH 32
	161168009	Screw MA 10-32 HX 48 (Marine)
7	630201049	Cover Top
	630000890	Cover Top (Marine)
8	630900888	Panel Splash



IMI CORNELIUS INC.  
 One Cornelius Place  
 Anoka, MN. 55303-6234  
 Telephone 1-800-238-3600  
 Facsimile 1-800-258-0255

www.cornelius.com

## ILLUSTRATED PARTS LIST

### XTREME ICE MAKER (630-830-1030 SERIES)

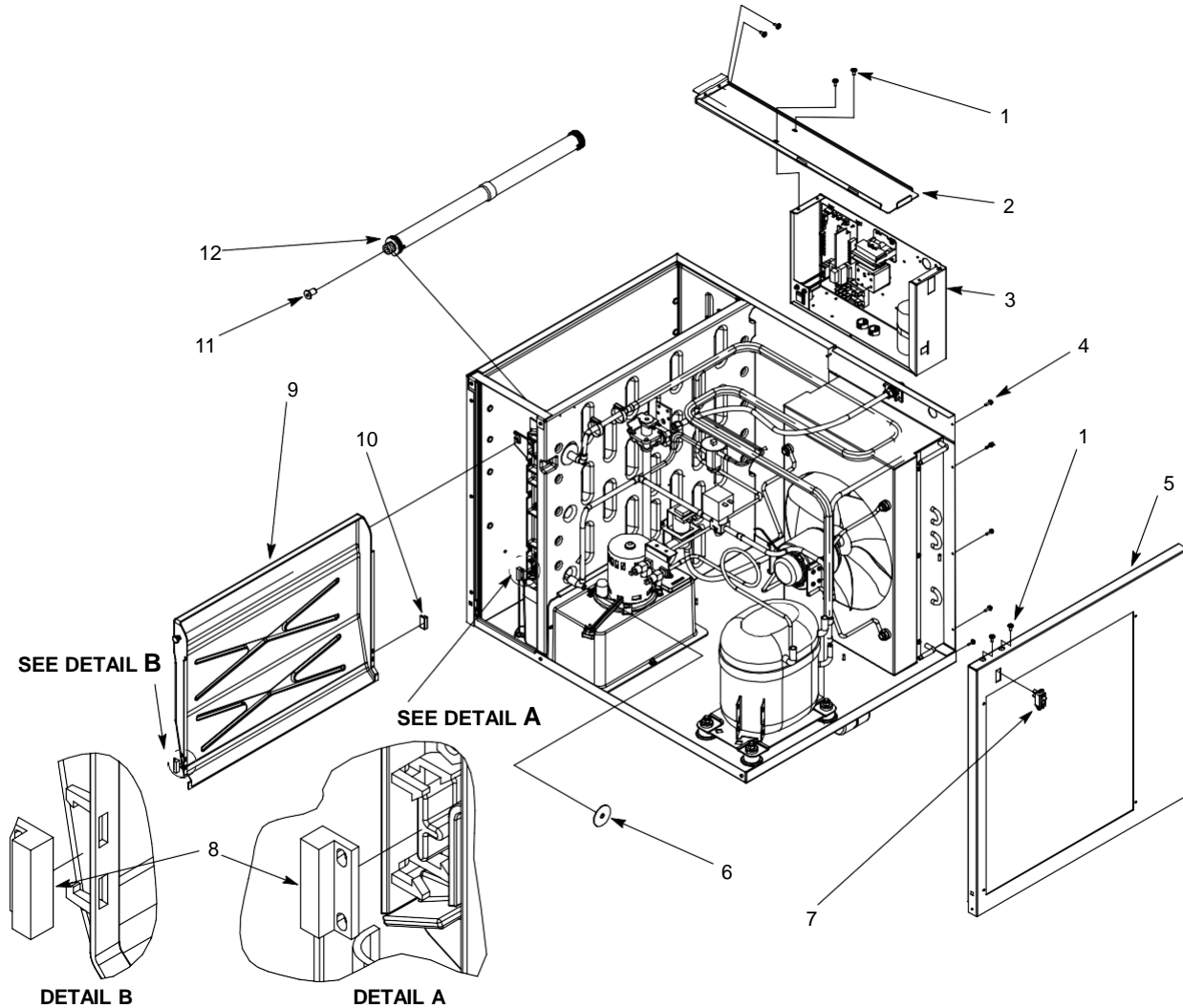

FIGURE 2. TRIM ASSEMBLY (AIR CONDENSER SHOWN)

Item No.	Part No.	Name
1	07578	Screw TC 8-32 TRPH 12
2	630201033	Brace Elec Box
3		Elec Box Assy (See Figure 10)
4	165384000	Screw SM 8 TA HX 16
5	630201139	Panel Side RH (630-830)
	630201076	Panel Side RH (1030)
	630200510	Panel Accs Side RH (Marine)

Item No.	Part No.	Name
6	630901000	Washer SL .540 I.D.
7	630900924	Swt Rocker On/Off
8	<a href="#">630900798</a>	Switch Proximity
9	630900827	Cover Evap Large
10	630900870	Fitg Placeholder
11	630900908	Orifice Flow Reducer
12	631500120	Kit Svc Water Distributor Assy (See Figure 11)



IMI CORNELIUS INC.  
 One Cornelius Place  
 Anoka, MN. 55303-6234  
 Telephone 1-800-238-3600  
 Facsimile 1-800-258-0255

www.cornelius.com

## ILLUSTRATED PARTS LIST

### XTREME ICE MAKER (630-830-1030 SERIES)

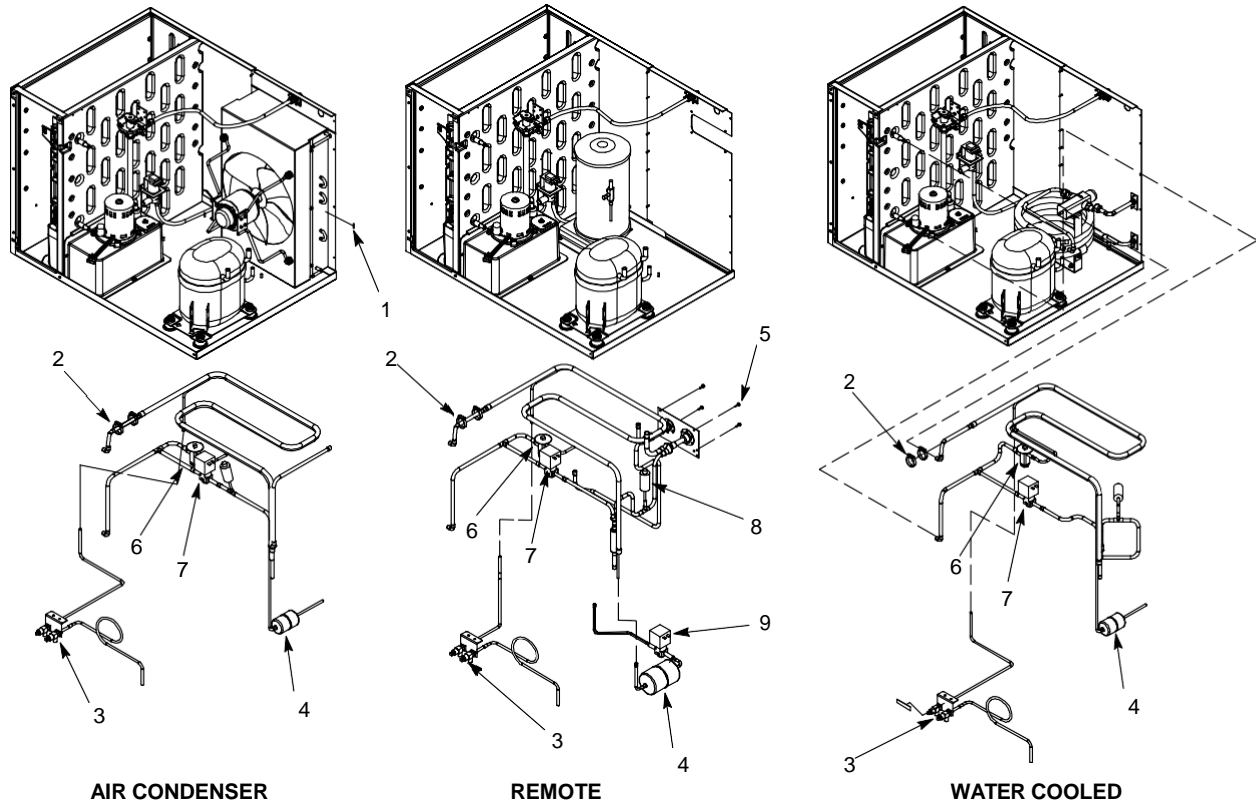

FIGURE 3. REFRIGERATION ASSEMBLY

Item No.	Part No.	Name
1	<a href="#">161862005</a>	Sensor Tmp (Air Condenser)
2	161426001	Clamp Ger No. 12
3	630000786	Valve and Brkt Svc (630)
	630000851	Valve and Brkt Svc (830-1030)
4	166184002	Dryer Filter (630)
	166184003	Dryer Filter (830-1030)

Item No.	Part No.	Name
5	165384000	Screw SM 8 TA HX 16 (Remote)
6	630901023	Valve 1 Ton (630)
	<a href="#">161921008</a>	Valve Expan (830-1030)
7	165629007	Valve Hot Gas
8	630000843	Switch Prs Asy 500-PSI
9	165629010	Solenoid Liq



IMI CORNELIUS INC.  
 One Cornelius Place  
 Anoka, MN. 55303-6234  
 Telephone 1-800-238-3600  
 Facsimile 1-800-258-0255

www.cornelius.com

## ILLUSTRATED PARTS LIST

### XTREME ICE MAKER (630-830-1030 SERIES)

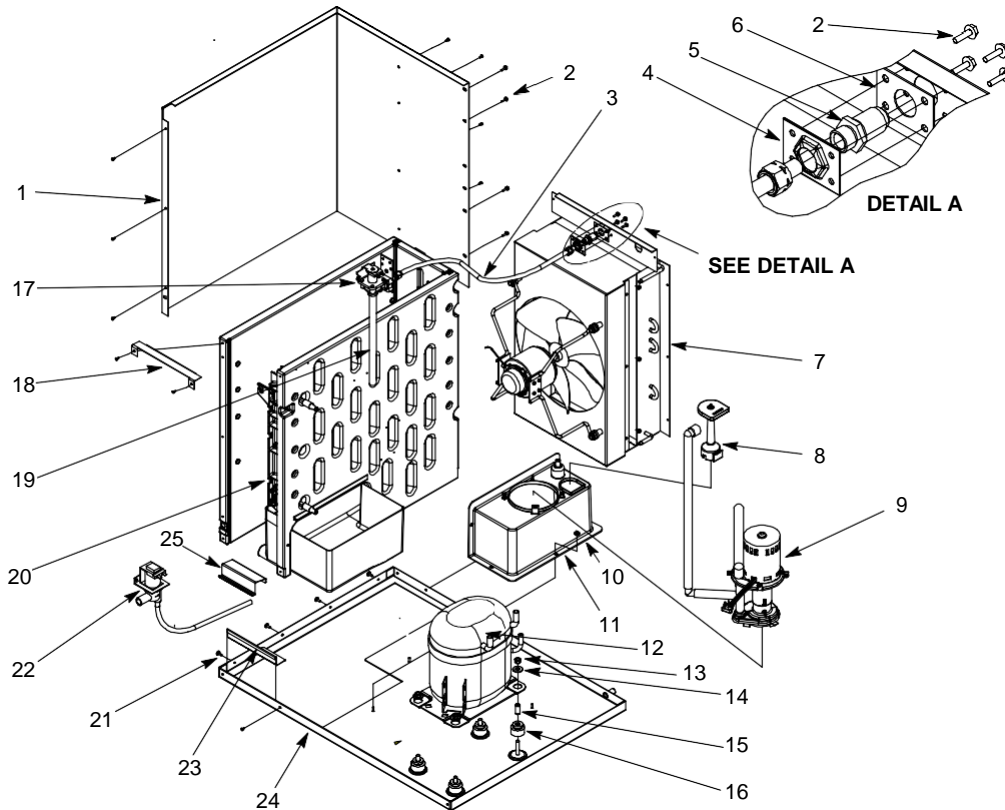

FIGURE 4. BUILD ASSEMBLY (AIR CONDENSER)

Item No.	Part No.	Name
1	630201138	Wrap Cab (630-830)
	630201196	Wrap Cab (1030)
2	165384000	Screw SM 8 TA HX 16
3	650057	Tube Poly .265 I.D. (Sold by the Foot)
4	630200935	Flange Bulkhead Fitg
5	630900783	Fitg Blkhd
6	630201072	Flange Bulkhead Fitg Flat
7		Condenser Asy (See Figure 9)
8	630900868	Sensor Pressure Pick-up
9		Water Pump Asy (See Figure 12)
10	630900895	Nut Hex 8-32
11	630900869	Pan Water Wrap
12	631500144	Kit Compressor 240V 60HZ (630)
	631500085	Kit Compressor 230V 50HZ (630)
	631500145	Kit Compressor, 240V 60HZ (830)
	631500086	Kit Compressor 230V 50HZ (830)
	631500146	Kit Compressor 240V 60HZ (1030)
	631500087	Kit Compressor 230V 50HZ (1030)

Item No.	Part No.	Name
13	164083005	Nut Hex 5/16-18
14	164154001	Washer Ft. .375 I.D.
15	630900745	Sleeve Grommet Comp (630-830)
	630900964	Sleeve Grommet Comp (1030)
16	630900744	Grommet Mount Comp (630-830)
	630900963	Grommet Mount Comp (1030)
17	<a href="#">630900791</a>	Valve Solenoid Water 3-GPM
18	630201036	Brace Bulkhead
19	638006070	Tube Vinyl .375 I.D. x 9
20		Bulkhead Asy (See Figure 7)
21	164126000	Screw SM 8 TRPH 16
22	165637009	Valve Dump
23	630201086	Brkt Water Pan
24	630000759	Base Chassis (630)
	630000850	Chassis (830)
	630000876	Chassis (1030)
25	630201126	Brkt Wtr Pan Cvr



IMI CORNELIUS INC.  
 One Cornelius Place  
 Anoka, MN. 55303-6234  
 Telephone 1-800-238-3600  
 Facsimile 1-800-258-0255

www.cornelius.com

## ILLUSTRATED PARTS LIST

### XTREME ICE MAKER (630-830-1030 SERIES)

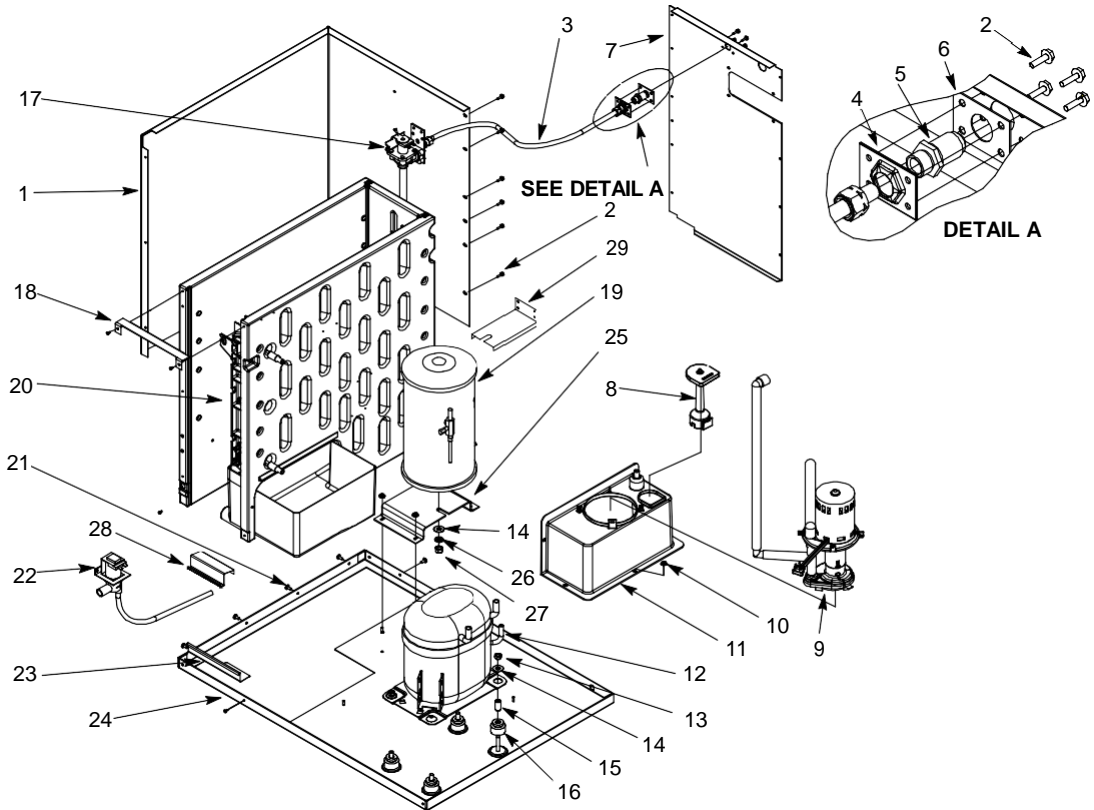

FIGURE 5. BUILD ASSEMBLY (REMOTE)

Item No.	Part No.	Name
1	630201138	Wrap Cab
2	165384000	Screw SM 8 TA HX 16
3	650057	Tube Poly .265 I.D. (Sold by the Foot)
4	630200935	Flange Bulkhead Fitg
5	630900783	Fitg Blkhd
6	630201072	Flange Bulkhead Fitg Flat
7	630201137	Panel Back
8	630900868	Sensor Pressure Pick-up
9		Water Pump Asy (See Figure 12)
10	630900895	Nut Hex 8-32
11	630900869	Pan Water Wrap
12	631500144	Kit Comp 240V 60HZ (630)
	631500085	Kit Comp 230V 50HZ (630)
	631500145	Kit Comp 240V 60HZ (830)
	631500086	Kit Comp 230V 50HZ (830)
	631500146	Kit Comp 240V 60HZ (1030)
	631500087	Kit Comp 230V 50HZ (1030)
13	164083005	Nut Hex 5/16-18
14	164154001	Washer Ft .375 I.D.

Item No.	Part No.	Name
15	630900745	Sleeve Grommet Comp (630-830)
	630900964	Sleeve Grommet Comp (1030)
16	630900744	Grommet Mount Comp (630-830)
	630900963	Grommet Mount Comp (1030)
17	<a href="#">630900791</a>	Valve Solenoid Water 3-GPM
18	630201036	Brace Bulkhead
19	166225000	Receiver
20		Bulkhead Asy (See Figure 7)
21	164126000	Screw SM 8 1RPH 16
22	165637009	Valve Dump
23	630201086	Brkt Wtr Pan
24	630000759	Base Chassis (630)
	630000850	Chassis (830-1030)
25	630201181	Brkt Rec Btm
26	01022	Washer Lk .380 I.D.
27	09652	Nut Hex 3/8-16
28	630201126	Brkt Wtr Pan Cvr
29	164820913	Brkt Rec Top



IMI CORNELIUS INC.  
 One Cornelius Place  
 Anoka, MN. 55303-6234  
 Telephone 1-800-238-3600  
 Facsimile 1-800-258-0255

www.cornelius.com

## ILLUSTRATED PARTS LIST

### XTREME ICE MAKER (630-830-1030 SERIES)

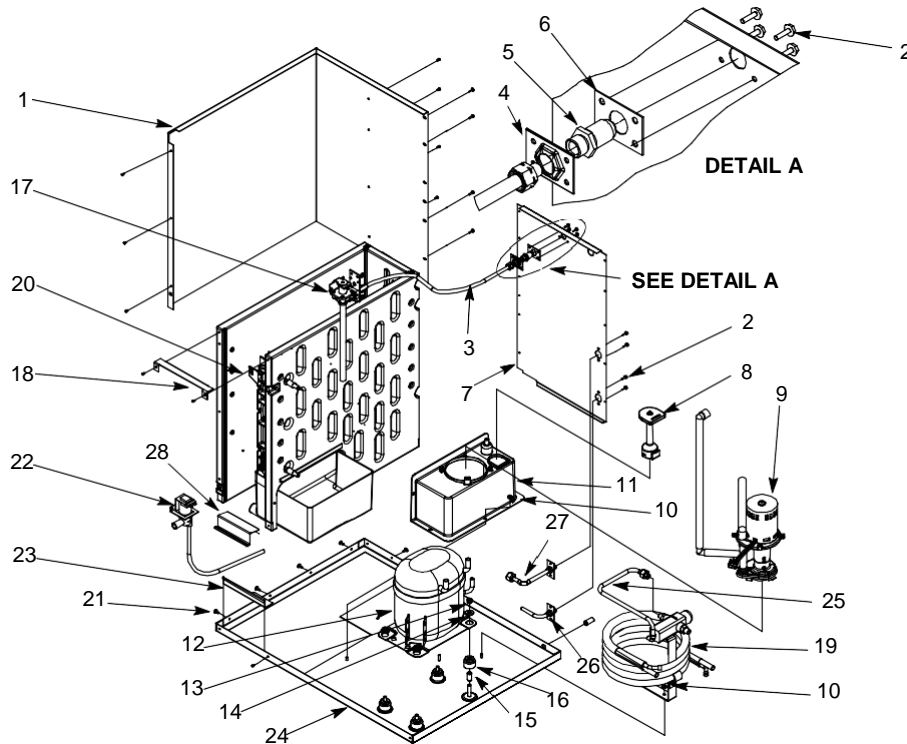

FIGURE 6. BUILD ASSEMBLY (WATER COOLED)

Item No.	Part No.	Name
1	630201138	Wrap Cab
2	165384000	Screw SM 8 HX 16
	161090000	Screw TC 8-32 HXWS 12 (Marine)
3	650057	Tube Poly .265 I.D. (Sold by the Foot)
4	630200935	Flange Bulkhead Fitg
5	630900783	Fitg Blkhd
6	630201072	Flange Bulkhead Fitg Flat
7	630201136	Panel Back
	630000891	Panel Back (Marine)
8	630900868	Sensor Pressure Pic-up
9		Water Pump Asy (See Figure 12)
10	630900895	Nut Hex 8-32
11	630900869	Pan Water Wrap
12	631500144	Kit Comp 240V 60HZ (630)
	631500085	Kit Comp 230V 50HZ (630)
	631500145	Kit Comp 240V 60HZ (830)
	631500086	Kit Comp 230V 50HZ (830)
	631500146	Kit Comp 240V 60HZ (1030)
	631500087	Kit Comp 230V 50HZ (1030)
13	164083005	Nut Hex 5/16-18
	164083006	Nut Hex 5/16-18 (Marine)
14	164154001	Washer Ft .375 I.D.
	164154002	Washer Ft .312 I.D. (Marine)

Item No.	Part No.	Name
15	630900745	Sleeve Grommet Comp (630)
	630900964	Sleeve Grommet Comp (830-1030)
16	630900744	Grommet Mount Comp (630)
	630900963	Grommet Mount Comp (830-1030)
17	<a href="#">630900791</a>	Valve Solenoid Water 3-GPM
18	630201036	Brace Bulkhead
19	08823	Cond Coil Asy (See Figure 14)
	08286	Clamp Coil Wtr (630-830; Not Shown)
	166196001	Clamp Coil Wtr (1030; Not Shown)
20		Bulkhead Asy (See Figure 7)
21	164126000	Screw SM 8 TRPH 16
22	165637009	Valve Dump
23	630201086	Brkt Wtr Pan
24	630000842	Base Chassis (630)
	630000852	Chassis (830-1030)
	630000892	Chassis (Marine)
25	161763011	Tube Asy Wtr Val to Cdr
26	164832013	Tube Water Inlet
27	164832010	Line Ast Wtr Out
28	630201126	Brkt Wtr Pan Cvr



IMI CORNELIUS INC.  
 One Cornelius Place  
 Anoka, MN. 55303-6234  
 Telephone 1-800-238-3600  
 Facsimile 1-800-258-0255

www.cornelius.com

## ILLUSTRATED PARTS LIST

### XTREME ICE MAKER (630-830-1030 SERIES)

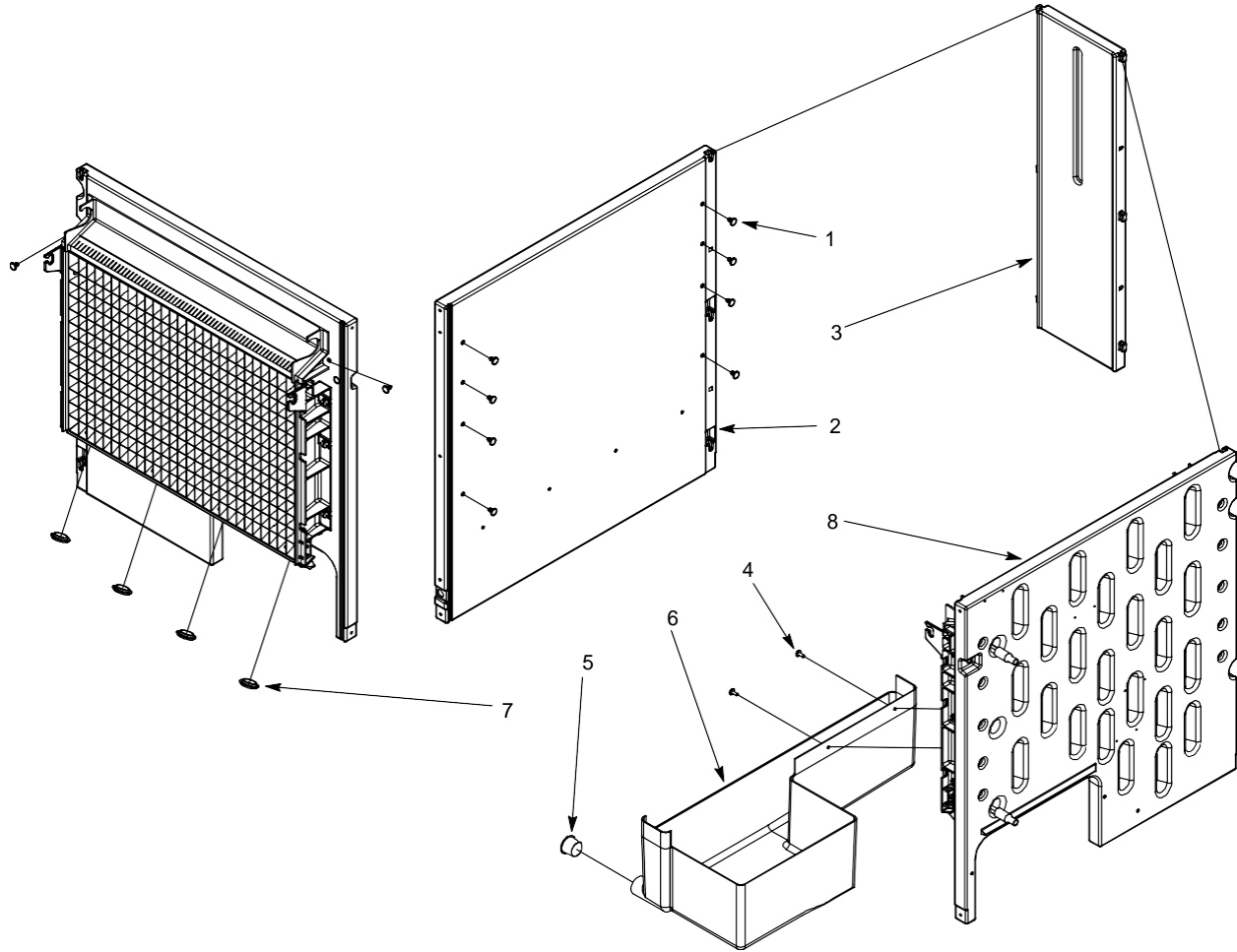

FIGURE 7. BULKHEAD ASSEMBLY

Item No.	Part No.	Name
1	630900903	Clip
2	630900847	Bulkhd LT
3	630900845	Bulkhd Rear
4	164126000	Screw SM 8 TRPH 16

Item No.	Part No.	Name
5	630900934	Cap
6	630900833	Pan Water Large
7	630900892	Plug Snap-in
8		Evaporator Asy (See Figure 8)





IMI CORNELIUS INC.  
 One Cornelius Place  
 Anoka, MN. 55303-6234  
 Telephone 1-800-238-3600  
 Facsimile 1-800-258-0255

www.cornelius.com

## ILLUSTRATED PARTS LIST

### XTREME ICE MAKER (630-830-1030 SERIES)

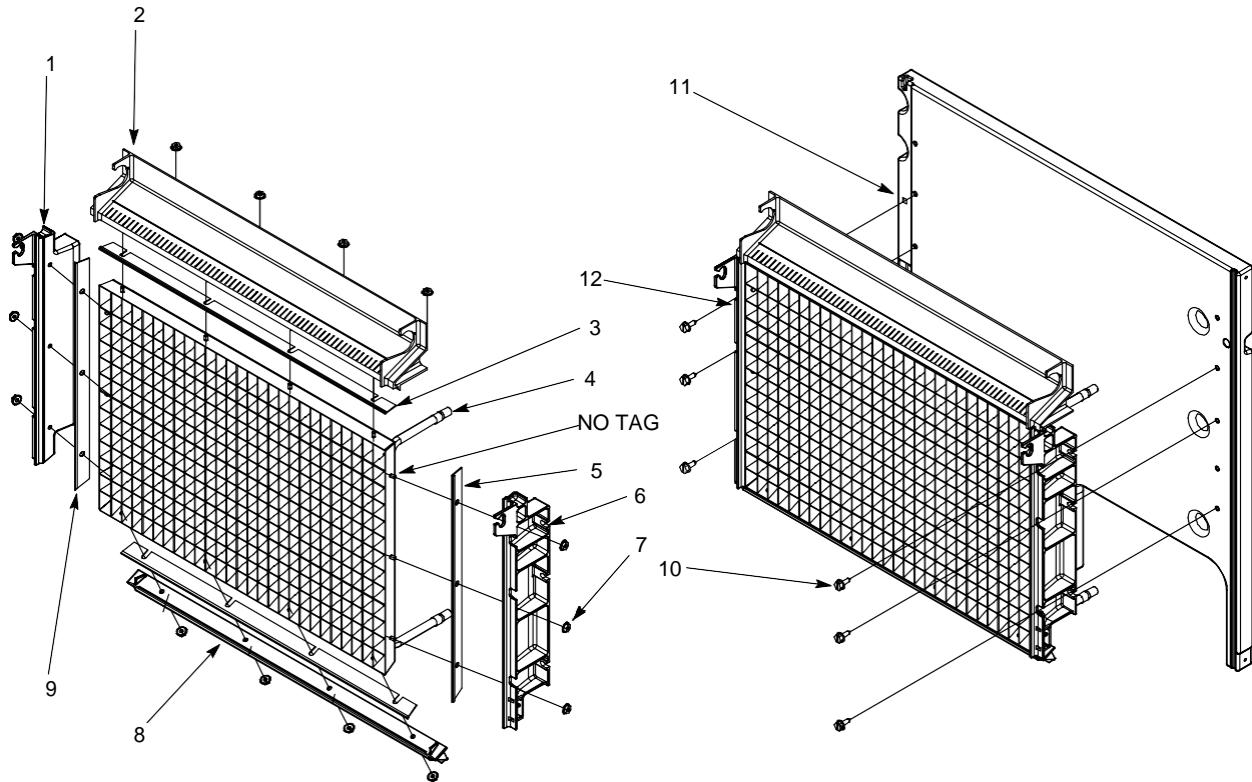

FIGURE 8. EVAPORATOR ASSEMBLY

Item No.	Part No.	Name
1	630900858	Frame Evap LH
2	630900781	Deflector Water
3	630201024	Gasket Frame Evap Top and Bottom
4	630900962	Tube Extension RH
	630000819	Evap and Plate
5	630201028	Gasket Frame Evap Right Large
6	630900859	Frame Evap RH
7	630900895	Nut Hex 8-32

Item No.	Part No.	Name
8	630900857	Frame Evap Bottom
9	630201027	Gasket Frame Evap Left Large
10	630900896	Screw SM 14 HX 20
11	630900849	Bulkhd Rt
12	631500135	Kit Svc Evap Frame Asy (Standard Cube)
	631500138	Kit SVC Evap Frame Asy (Large Cube)



IMI CORNELIUS INC.  
 One Cornelius Place  
 Anoka, MN. 55303-6234  
 Telephone 1-800-238-3600  
 Facsimile 1-800-258-0255

www.cornelius.com

## ILLUSTRATED PARTS LIST

### XTREME ICE MAKER (630-830-1030 SERIES)

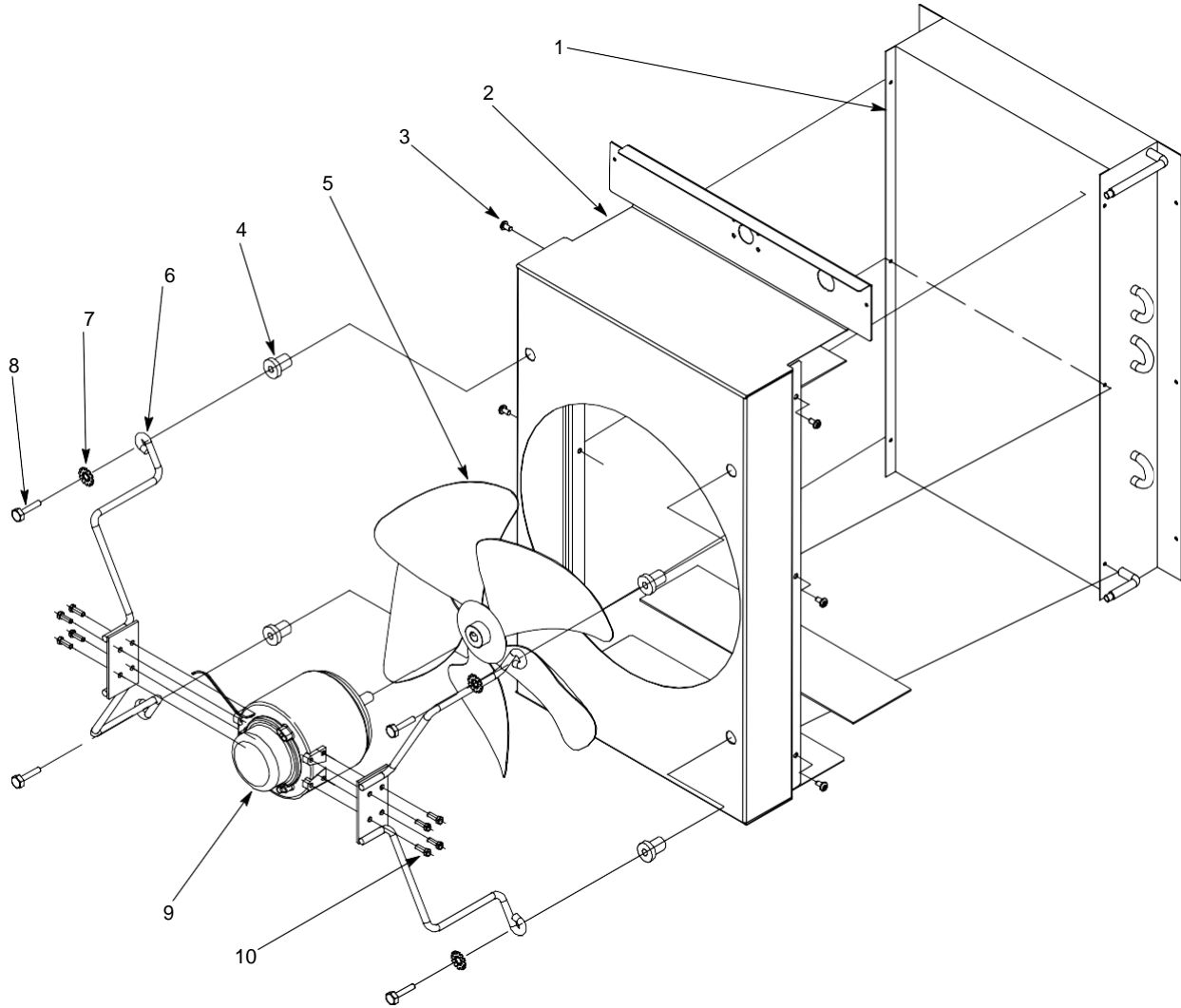

**FIGURE 9. CONDENSER ASSEMBLY**

Item No.	Part No.	Name
1	38668	Cond Coil Air (630-830)
	630900921	Cond Coil Air (1030)
2	630201135	Shroud Cond (630-830)
	630201081	Shroud Cond (1030)
3	630900190	Screw SM 8 PAPH 12
4	630900889	Nut Well 1/4-20
5	630900245	Fan 3-Bld (630-830)
	630900920	Fan Blade (1030)
6	630900961	Brkt Wire Fan (630-830)
	630900919	Brkt Wire Fan Mtr (1030)

Item No.	Part No.	Name
7	23978	Washer Sr .690 I.D.
8	165294000	Bolt MA 1/4-20 HX 32
9	630000611	Motor Assy Fan 240V 60HZ (630-830)
	166181012	Motor Asy Fan 230V 50HZ (630-830)
	630900308	Motor Fan 240V 60HZ (1030)
	166181011	Motor Asy Fan 230V 50HZ (1030)
10	03612	Screw MA 8-36 HX 16



IMI CORNELIUS INC.  
 One Cornelius Place  
 Anoka, MN. 55303-6234  
 Telephone 1-800-238-3600  
 Facsimile 1-800-258-0255

www.cornelius.com

## ILLUSTRATED PARTS LIST

### XTREME ICE MAKER (630-830-1030 SERIES)

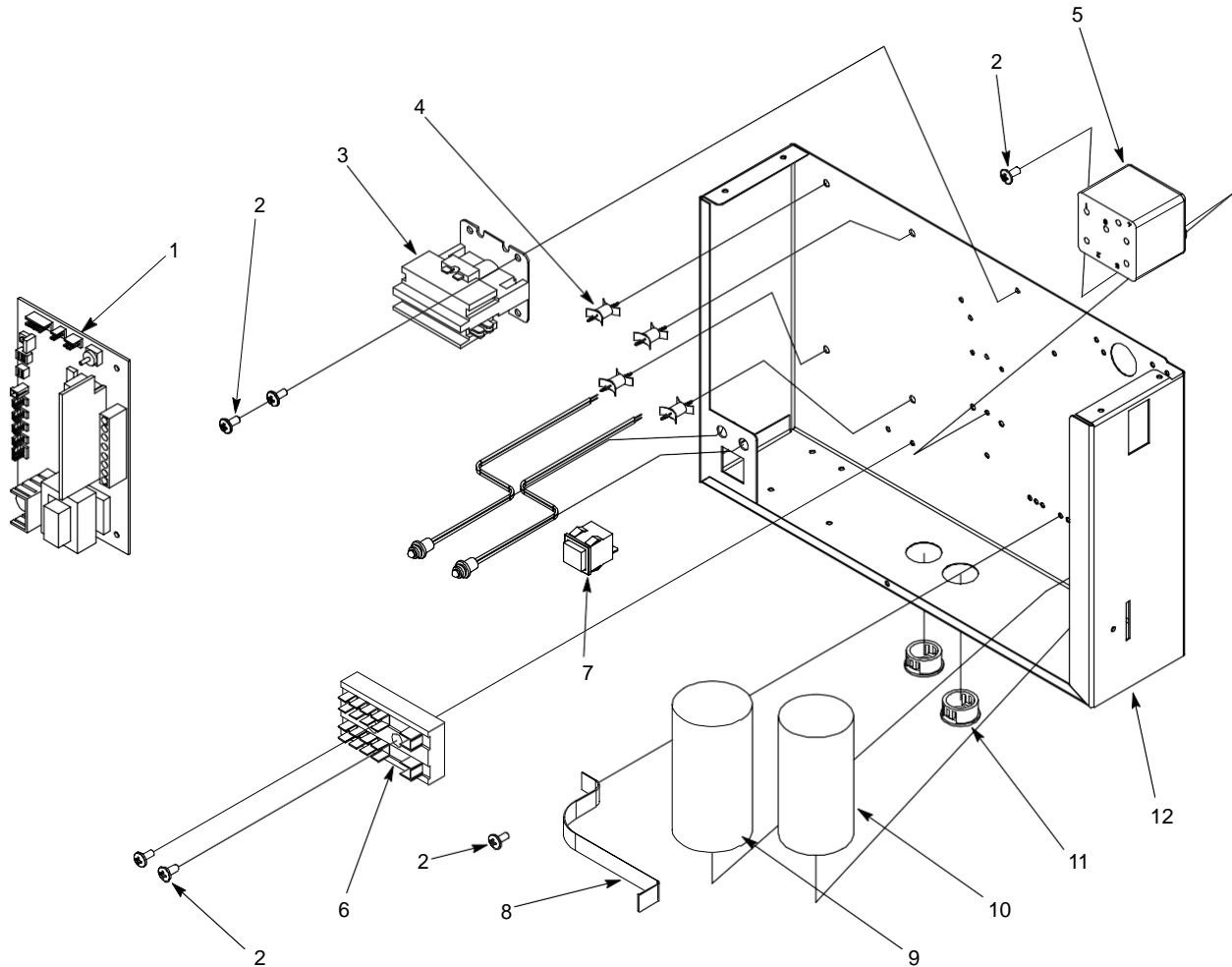

FIGURE 10. ELECTRICAL BOX ASSEMBLY

Item No.	Part No.	Name
1	<a href="#">630900789</a>	Board Control Pressure Sensor
2	07578	Screw TC 8-32 TRPH 12
3	40713	Relay 208/240V 50/60HZ
4	630460105	Spacer Circ Board
5	630900968	Relay Start 240V 60HZ (630)
	630901025	Relay Start 230V 50HZ (630)
	630900976	Relay Start (830)
	630900965	Relay Start (1030)
6	161838002	Block Term
7	630900905	Switch Push Btn
8	630200166	Cap Strap

Item No.	Part No.	Name
9	630900969	Capac Run 240V 60HZ (630)
	630901059	Capac Run 230V 50HZ (630)
	630900977	Capac Run (830)
	630900967	Capac Run (1030)
10	630900970	Capac Start (630)
	630900975	Capac Start (830)
	630900966	Capac Start (1030)
11	03611	Bushing Snap
12	630201035	Wrap Elec Box
	630201246	Wrap Elec Box (Marine)



IMI CORNELIUS INC.  
 One Cornelius Place  
 Anoka, MN. 55303-6234  
 Telephone 1-800-238-3600  
 Facsimile 1-800-258-0255

www.cornelius.com

## ILLUSTRATED PARTS LIST

### XTREME ICE MAKER (630-830-1030 SERIES)

Item No.	Part No.	Name
1	630900883	Cap Plug
2	630900780	Distributor Water Inner
3	630900809	O-Ring .075 I.D.
4	630900779	Distributor Water Inner Barb
5	630900777	Distributor Water Asy

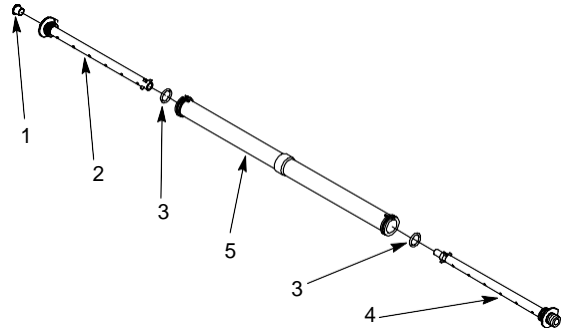

FIGURE 11. WATER DISTRIBUTOR ASSEMBLY

Item No.	Part No.	Name
1	630900881	Tube Vinyl Pmp to Dmp Vlv
2	630900796	Pump Water 240V 50/60HZ
3	630900929	Tube Vinyl Pmp to Wtr Dis
4	630900874	Tube Vinyl Pmp to Out
5	166092000	Fitg Elbow
6	163242002	Clamp Hose (Not Shown)

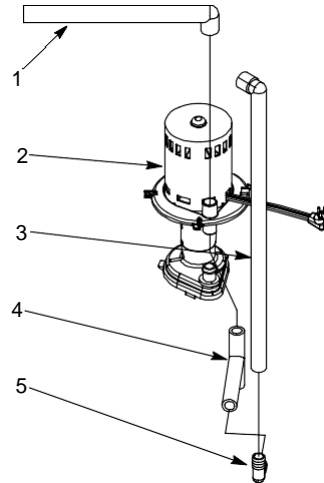

FIGURE 12. WATER PUMP ASSEMBLY

Item No.	Part No.	Name
1	630201021	Panel Fnt
2	630900853	Cap Front Panel
3	630201018	Rail LT Fnt Pnl
4	630201020	Rail Rt Fnt Pnl

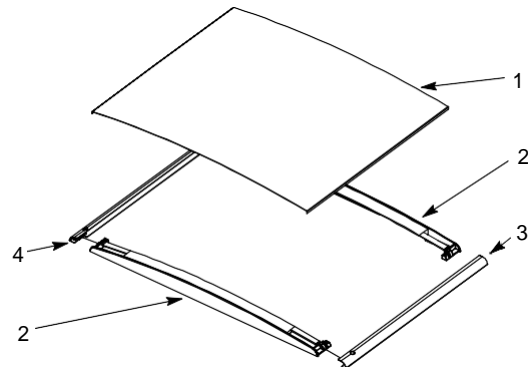

FIGURE 13. FRONT PANEL ASSEMBLY



IMI CORNELIUS INC.  
 One Cornelius Place  
 Anoka, MN. 55303-6234  
 Telephone 1-800-238-3600  
 Facsimile 1-800-258-0255

www.cornelius.com

## ILLUSTRATED PARTS LIST

### XTREME ICE MAKER (630-830-1030 SERIES)

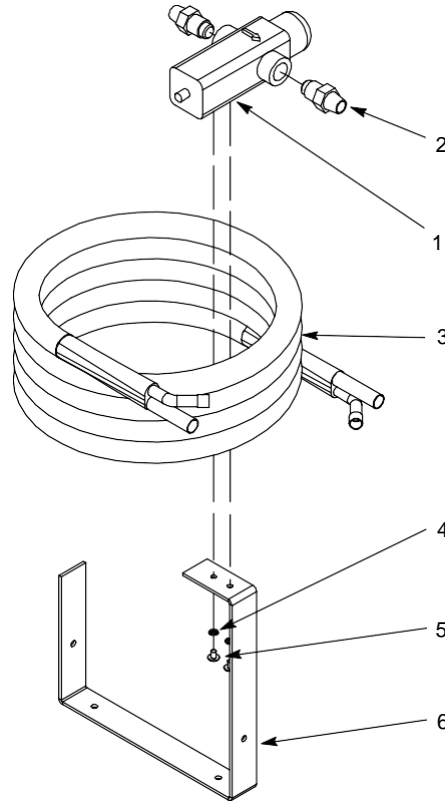

FIGURE 14. WATER COIL ASSEMBLY

Item No.	Part No.	Name
1	<a href="#">164980002</a>	Valve Wtr Reg
2	08699	Fitg 5/8-18 x 3/8-MPT
3	08823	Cond Coil Water (630-830)
	27177	Cond Coil Water (1030)

Item No.	Part No.	Name
4	00214	Washer Lk .2966 I.D.
5	161168000	Screw MA 8-32 TRPH 8
6	164823009	Brkt Reg Wtr Water Coil (1030)



IMI CORNELIUS INC.  
One Cornelius Place  
Anoka, MN. 55303-6234  
Telephone 1-800-238-3600  
Facsimile 1-800-258-0255

[www.cornelius.com](http://www.cornelius.com)

## ILLUSTRATED PARTS LIST

---

### **XTREME ICE MAKER (630-830-1030 SERIES) ACCESSORIES/KITS**