



IMI CORNELIUS INC.
One Cornelius Place
Anoka, MN. 55303-6234
Telephone 1-800-238-3600
Facsimile 1-800-258-0255

www.cornelius.com

ILLUSTRATED PARTS LIST

XTREME ICE MAKER (1444 AND 1844 SERIES)

MODEL NO.

631814001
631814002
631814003
631814004
631814020
631814040
631814041
631818001
631818002
631818003
631818050
631818051
631818052

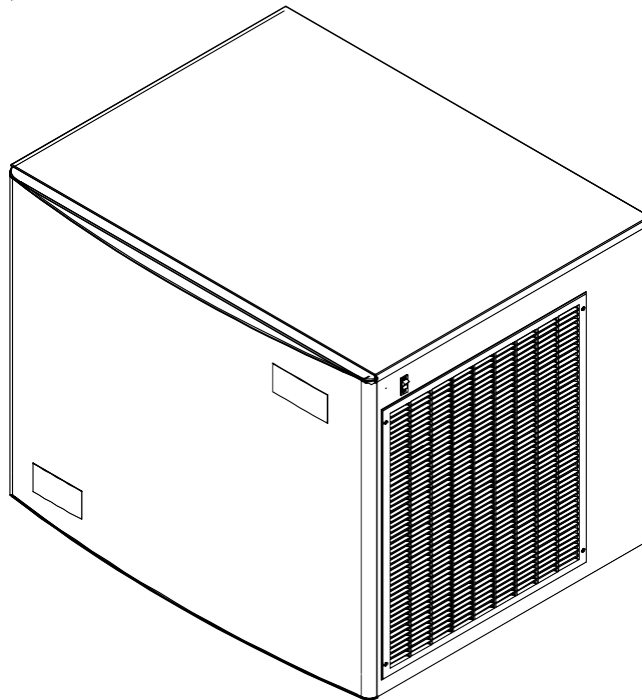



IMI CORNELIUS INC.
 One Cornelius Place
 Anoka, MN. 55303-6234
 Telephone 1-800-238-3600
 Facsimile 1-800-258-0255

www.cornelius.com

ILLUSTRATED PARTS LIST

XTREME ICE MAKER (1444 AND 1844 SERIES)

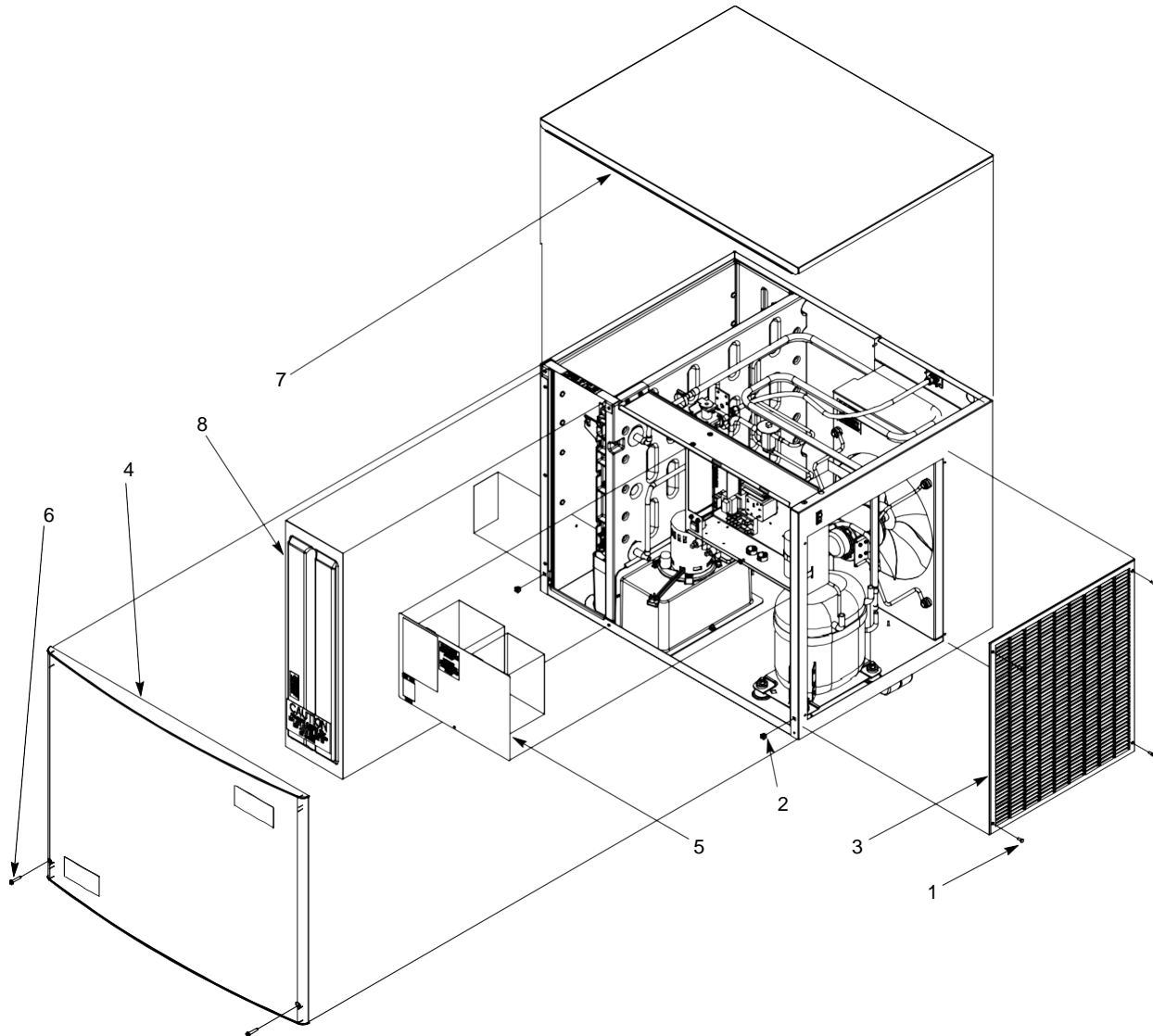

FIGURE 1. GENERAL ASSEMBLY (AIR CONDENSER SHOWN)

Item No.	Part No.	Name
1	161168006	Screw TC 8-32 HXWS 12
	161090000	Screw TC 8-32 HXWS 10 (Marine)
2	164510000	Grommet Nut
3	166194001	Grille
	630200510	Grille (Marine)
4	631500096	Front Panel Ass'y (See Figure 11)

Item No.	Part No.	Name
5	630201041	Cover, Electrical Box (1444)
	630201235	Cover, Electrical Box (1844)
	630201247	Cover, Electrical Box (Marine)
6	318308000	Screw TR 10-32 PAPH 32
7	630201194	Cover, Top
8	630900887	Splash Panel



IMI CORNELIUS INC.
 One Cornelius Place
 Anoka, MN. 55303-6234
 Telephone 1-800-238-3600
 Facsimile 1-800-258-0255

www.cornelius.com

ILLUSTRATED PARTS LIST

XTREME ICE MAKER (1444 AND 1844 SERIES)

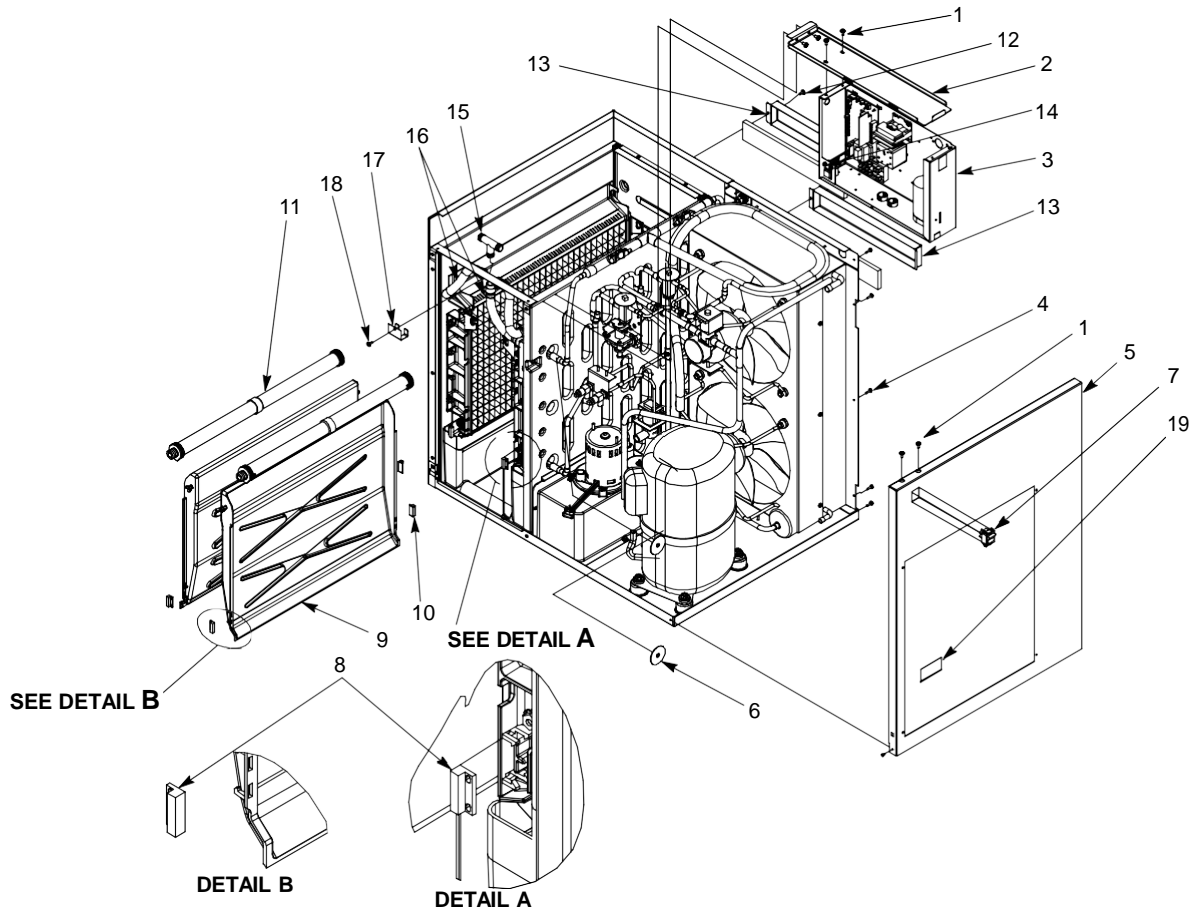

FIGURE 2. TRIM ASSEMBLY (AIR CONDENSER SHOWN)

Item No.	Part No.	Name
1	07578	Thread Cutting Screw, Phil Truss Hd, No. 8-32 By 3/8-In. Long
2	630201160 630201271	Brace, Electrical Box Brace, Electrical Box (Marine)
3		Electrical Box Ass'y (See Figure 8)
4	165384000	Sheet Metal Screw, No. 8 By 1/2-In. Long
5	630201076 630201254	Panel, Side Panel, Side (Marine)
6	630901000	Washer, .340 I.D.
7	630900924	Switch, On/Off
8	630900798	Switch, Proximity
9	630900827	Cover, Evaporator, Large

Item No.	Part No.	Name
10	630900870	Fitting, Placeholder
11	631500120	Water Distributor Ass'y (See Figure 9)
12	164126000	Screw
13	630201190	Recess Panel
14	00311	Grommet
15	00987	Fitting
16	630900818	Tube, Vynl Mold
17	630201093	Bracket, Vynl Tube
18	164713001	Screw
19	162445002	Clip



IMI CORNELIUS INC.
 One Cornelius Place
 Anoka, MN. 55303-6234
 Telephone 1-800-238-3600
 Facsimile 1-800-258-0255

www.cornelius.com

ILLUSTRATED PARTS LIST

XTREME ICE MAKER (1444 AND 1844 SERIES)

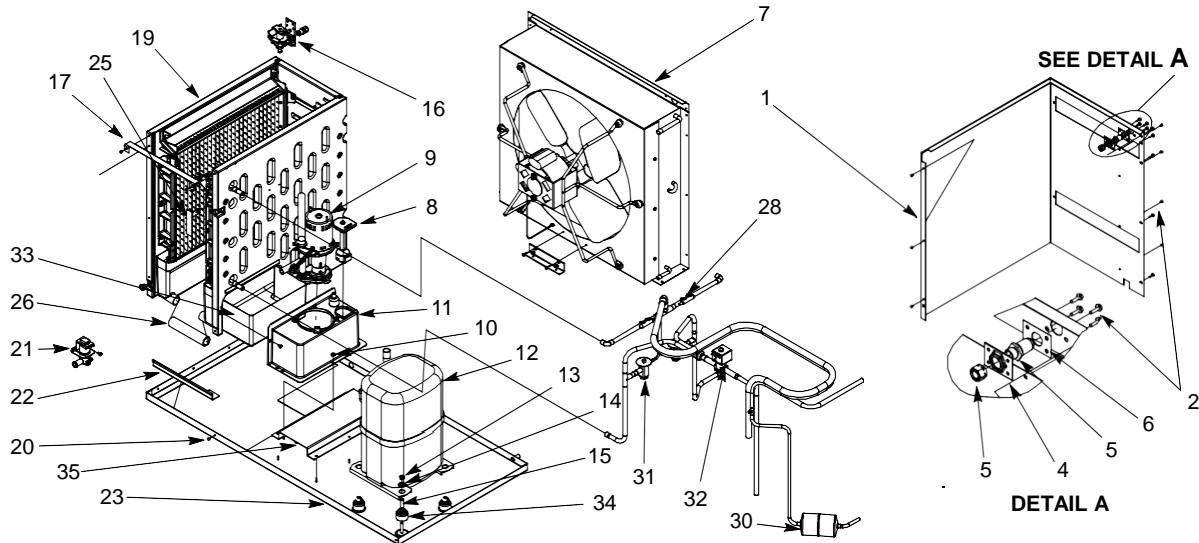

FIGURE 3. BUILD ASSEMBLY (AIR CONDENSER)

Item No.	Part No.	Name
1	630201156	Wrap, Cabinet (1444)
	630201249	Wrap, Cabinet (1844)
2	165384000	Sheet Metal Screw, No. 8 By 1/2"
3	420906000	Tube, .265 I.D. (Not Shown)
4	630200935	Flange, Bulkhead
5	630900783	Fitting, Bulkhead
6	630201072	Flange, Bulkhead
7		Condenser Ass'y (See Figure 7)
8	630900868	Pressure Sensor Ass'y
9		Water Pump Ass'y (See Figure 10)
10	630900895	Hex Nut, No. 8-32
11	630900869	Pan, Water Wrap
12	631500148	Kit Comp 208V 60HZ (1444)
	631500161	Kit Comp 3HP 240V 50HZ (1444)
	631500098	Kit Comp 3-1/4HP 240V 60HZ (1844; 1PH)
	631500097	Kit Comp 3-1/4HP 230V 60HZ (1844; 3PH)
13	164083005	Hex Nut, 5/16-18
14	164154001	Washer, .375 I.D.
15	630900964	Sleeve Grommet 60HZ (1444)
	165596002	Sleeve Grommet 50HZ (1444)
	165596003	Sleeve Grommet (1844)
16	630900791	Solenoid Valve

Item No.	Part No.	Name
17	630201038	Brace, Bulkhead
18	638006070	Tube, .375 I.D. (Not Shown)
19		Bulkhead Ass'y (See Figure 6)
20	164126000	Screw, SM 8 PHTR 16
21	165637009	Dump Valve
22	630201113	Bracket, Water Pan
23	630000853	Base (1444)
	630000894	Base (1844)
24	630201112	Bracket (Not Shown)
25	630201092	Clip
26	630900930	Tube, Vynl
27	161862005	Sensor Temp (Not Shown)
28	161462001	Clamp, Screw
29	630000854	Service Valve and Bracket Ass'y (1444; Not Shown)
	630000886	Service Valve and Bracket Ass'y (1844; Not Shown)
30	166184003	Dryer
31	161921008	Expansion Valve (1444)
	630901095	Expansion Valve (1844)
32	165629009	Hot Gas Valve
33	630900833	Water Pan
34	630900963	Grommet
35	630201267	Bracket, Stiffener
36	630201250	Bracket, Fan Motor (Not Shown)



IMI CORNELIUS INC.
 One Cornelius Place
 Anoka, MN. 55303-6234
 Telephone 1-800-238-3600
 Facsimile 1-800-258-0255

www.cornelius.com

ILLUSTRATED PARTS LIST

XTREME ICE MAKER (1444 AND 1844 SERIES)

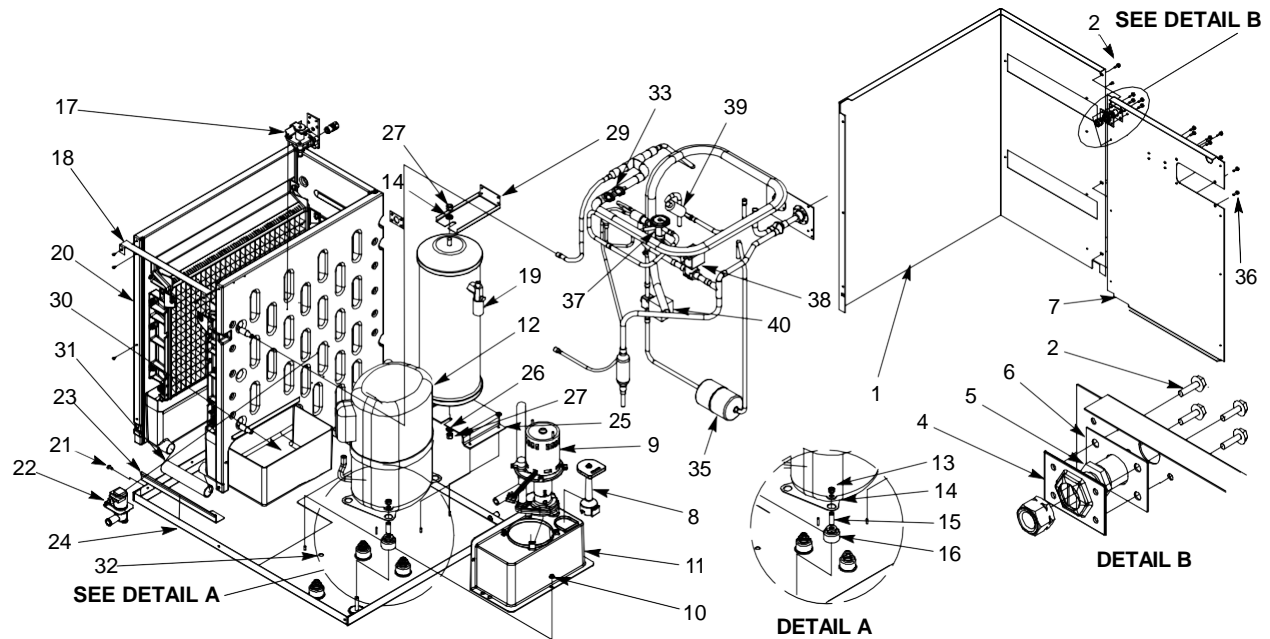

FIGURE 4. BUILD ASSEMBLY (REMOTE)

Item No.	Part No.	Name
1	630201156	Wrap, Cabinet
2	165384000	Sheet Metal Screw, No. 8 By 1/2-In.
3	420906000	Tube, .265 I.D. (Not Shown)
4	630200935	Flange, Bulkhead
5	630900783	Fitting, Bulkhead
6	630201072	Flange, Bulkhead
7	630201158	Panel, Back
8	630900868	Pressure Sensor Ass'y
9	Water Pump Ass'y (See Figure 10) 10	
	630900895	Hex Nut, No. 8-32
11	630900869	Pan, Water, Wrap
12	631500148	Kit Comp 208V 60HZ (1444)
	631500098	Kit Comp 3-1/4HP 240V 60HZ (1844; 1PH)
	631500097	Kit Comp 3-1/4HP 230V 60HZ (1844; 3PH)
13	164083005	Hex Nut, 5/16-18
14	164154001	Washer, .375 I.D.
15	630900964	Sleeve, Grommet(1444)
	165596003	Sleeve, Grommet(1844)
16	630900963	Grommet (1444)
17	630900791	Solenoid Valve
18	630201038	Brace, Bulkhead
19	166225000	Receiver (1444)
	630901097	Receiver (1844)
20		Bulkhead Ass'y (See Figure 6)

Item No.	Part No.	Name
21	164126000	Screw SM 8 PHTR 16
22	165637009	Dump Valve
23	630201113	Bracket, Water Pan
24	630000853	Base (1444)
	630000894	Base (1844)
25	630201234	Mounting Plate, Receiver (1444)
	630201270	Mounting Plate, Receiver (1844)
26	01022	Washer
27	09652	Hex Nut
28	630201112	Bracket (Not Shown)
29	630201182	Bracket, Receiver Top
30	630900833	Water Pan
31	630900930	Tube, Vynl
32	300098000	Button Plug
33	161426001	Clamp
34	630000854	Service Valve and Bracket(1444)
	630000886	Service Valve and Bracket(1844)
35	166184003	Dryer
36	165384000	Screw
37	161921008	Expansion Valve (1444)
	630901095	Expansion Valve (1844)
38	165629009	Hot Gas Valve
39	165677008	Switch Ass'y
40	165629011	Solenoid Valve



IMI CORNELIUS INC.
 One Cornelius Place
 Anoka, MN. 55303-6234
 Telephone 1-800-238-3600
 Facsimile 1-800-258-0255

www.cornelius.com

ILLUSTRATED PARTS LIST

XTREME ICE MAKER (1444 AND 1844 SERIES)

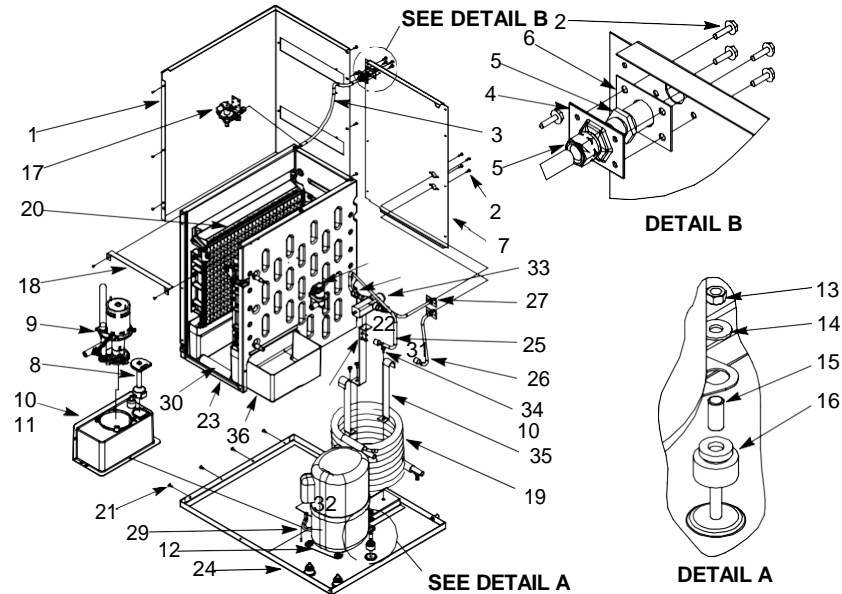

FIGURE 5. BUILD ASSEMBLY (WATER COOLED)

Item No.	Part No.	Name
1	630201156	Wrap, Cabinet
2	165384000	Screw SM 8 HX 16
	161090000	Screw TC 8-32 HXWS 10 (Marine)
3	420906000	Tube, .265 I.D.
4	630200935	Flange, Bulkhead
5	630900783	Fitting, Bulkhead
6	630201072	Flange, Bulkhead
7	630201157	Panel, Back
	630000899	Panel, Back (Marine)
8	630900868	Pressure Sensor Ass'y
9		Water Pump Ass'y (See Figure 10)
10	630900895	Hex Nut, No. 8-32
11	630900869	Pan, Water, Wrap
12	631500148	Kit Comp 208V 60HZ (1444)
	631500098	Kit Comp 3-1/4HP 240V 60HZ (1844; 1PH)
	631500097	Kit Comp 3-1/4HP 230V 60HZ (1844; 3PH)
13	164083005	Hex Nut, 5/16-18
	164083006	Hex Nut, 5/16-18 (Marine)
14	164154001	Washer, .375 I.D.
	164154002	Washer Ft. .312 I.D. (Marine)
15	630900964	Sleeve, Grommet (1444)
	165596003	Sleeve, Grommet (1844)
16	630900963	Grommet (1444)
	630201266	Grommet (1844)
17	630900791	Solenoid Valve
18	630201038	Brace, Bulkhead

Item No.	Part No.	Name
19	164838004	Water Coil Ass'y (1444)
	630901090	Water Coil Ass'y (1844)
20		Bulkhead Ass'y (See Figure 6)
21	164126000	Sheet Metal Screw, Phil Truss Hd, No. 8 By 1/2-In. Long
22	165637009	Dump Valve
23	630201113	Bracket, Water Pan
24	630000853	Base (1444)
	630000894	Base (1844)
	630000898	Base (Marine)
25	161763012	Tube Ass'y (1444)
	630250160	Tube Ass'y (1844)
26	164832016	Tube Ass'y, Water Inlet (1444)
	630250158	Tube Ass'y, Water Outlet (1844)
27	164832015	Tube Ass'y, Water Outlet (1444)
	630250159	Tube Ass'y, Water Outlet (1844)
28	630201112	Bracket (Not Shown)
29	300098000	Button Plug
30	630900930	Tube, Vynl
31	161426001	Clamp
32	00214	Washer
33	164980002	Valve, Water Regulator
34	161189000	Washer
35	166196002	Clamp, Water Coil
	630200325	Clamp, Water Coil (Marine)
36	630900833	Water Pan
37	630201268	Bracket Water Coil Fnt (Not Shown)
38	630201269	Bracket Water Coil Bck (Not Shown)



IMI CORNELIUS INC.
 One Cornelius Place
 Anoka, MN. 55303-6234
 Telephone 1-800-238-3600
 Facsimile 1-800-258-0255

www.cornelius.com

ILLUSTRATED PARTS LIST

XTREME ICE MAKER (1444 AND 1844 SERIES)

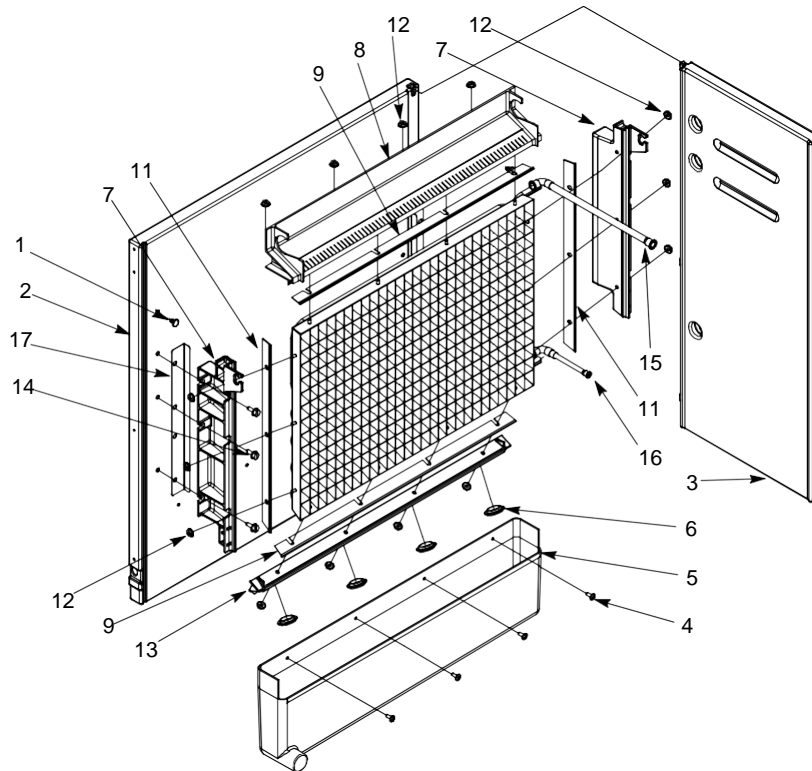

FIGURE 6. BULKHEAD ASSEMBLY

Item No.	Part No.	Name
1	630900903	Clip
2	630900847	Panel, Bulkhead Left
	630900849	Panel, Bulkhead, Right
3	630900844	Bulkhead, Rear
4	164126000	Sheet Metal Screw, Phil Truss Hd, No. 8 By 1/2-In. Long
5	630900833	Pan, Water, Large, Right
	630900835	Pan, Water, Large, Left
6	630900892	Plug
7	630900858	Frame, Evaporator, Left
	630900859	Frame, Evaporator, Right
8	630900781	Deflector, Water
9	630201024	Gasket, Frame, Top and Bottom
10	631500139	Kit Service Evap Frame Left (Standard Cube)
	631500140	Kit Service Evap Frame Left (Large Cube)

Item No.	Part No.	Name
	631500135	Kit Service Evap Frame Right (Standard Cube)
	631500138	Kit Service Evap Frame Right (Large Cube)
11	630201027	Gasket, Side, Left
	630201028	Gasket, Side, Right
12	630900895	Hex Nut, No. 8-32
13	630900857	Frame, Evaporator, Bottom
14	630900896	Sheet Metal Screw, Hex Hd, No. 14 by 5/8"
15	630250142	Evaporator Line, Upper, Left
	630900962	Evaporator Line, Upper, Right
16	630250142	Evaporator Line, Lower, Left
	630900962	Evaporator Line, Lower, Right
17	630201242	Bracket, Evaporator Frame Support



IMI CORNELIUS INC.
 One Cornelius Place
 Anoka, MN. 55303-6234
 Telephone 1-800-238-3600
 Facsimile 1-800-258-0255

www.cornelius.com

ILLUSTRATED PARTS LIST

XTREME ICE MAKER (1444 AND 1844 SERIES)

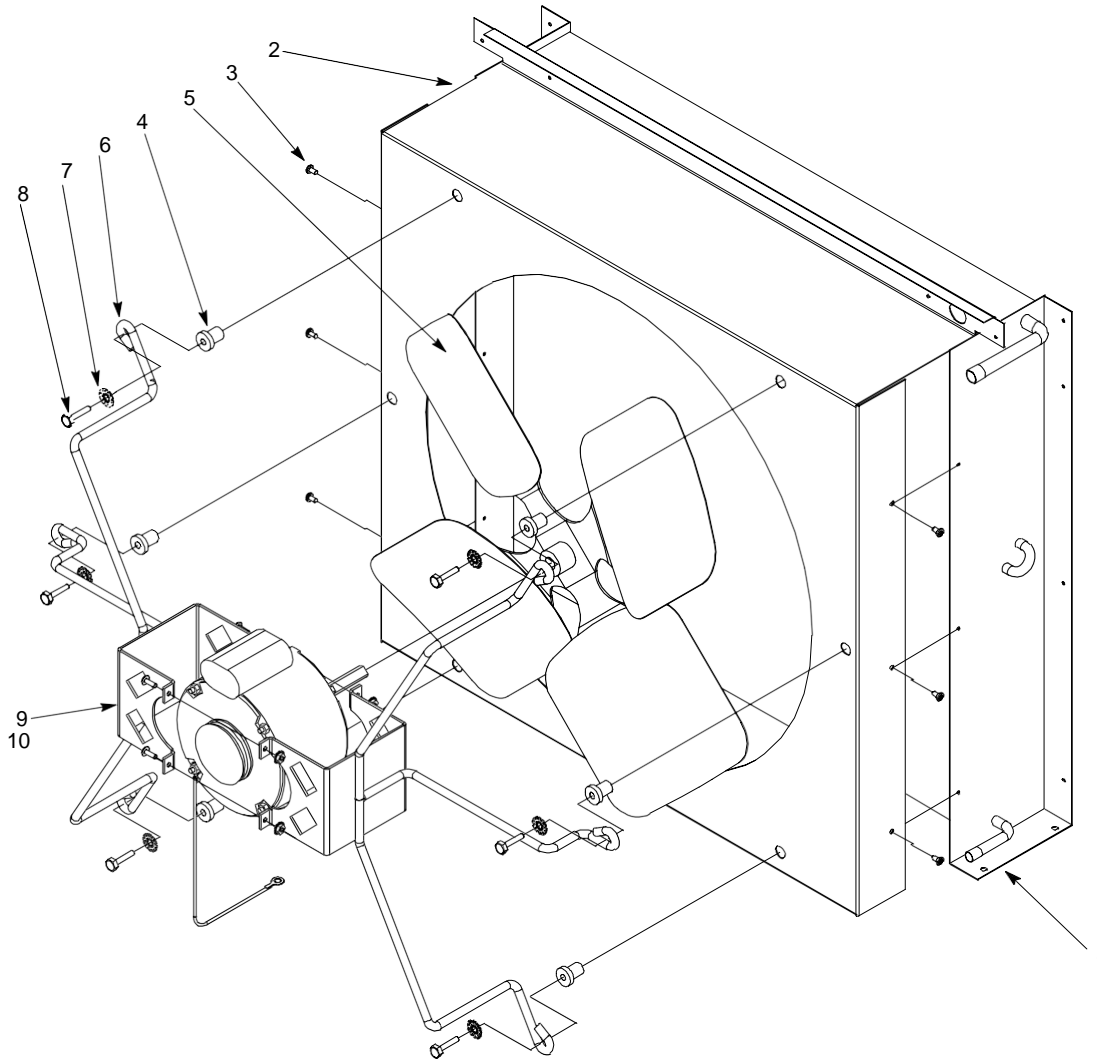

FIGURE 7. CONDENSER ASSEMBLY

Item No.	Part No.	Name
1	161870006	Condenser Coil (1444)
	630901072	Condenser Coil (1844)
2	630201159	Shroud, Condenser (1444)
	630201245	Shroud, Condenser (1844)
3	630900190	Sheet Metal Screw, Phil Pan Hd, No. 8 By 3/8-In. Long
4	630900889	Well Nut, 1/4-20
5	39898	Fan Blade (1444)
	630901093	Fan Blade (1844)

Item No.	Part No.	Name
6	630900998	Bracket, Motor
7	23978	Washer, .690 I.D.
8	165294000	Machine Screw, Hex Hd, 1/4-20 By 1-In. Long
9	630000870	Motor Cond 230V 50/60HZ (1444)
	630901092	Motor Cond 230V 50/60HZ (1844)
10	07667	Machine Screw, Hex Hd, No. 8-36 By 1/2-In. Long



IMI CORNELIUS INC.
 One Cornelius Place
 Anoka, MN. 55303-6234
 Telephone 1-800-238-3600
 Facsimile 1-800-258-0255

www.cornelius.com

ILLUSTRATED PARTS LIST

XTREME ICE MAKER (1444 AND 1844 SERIES)

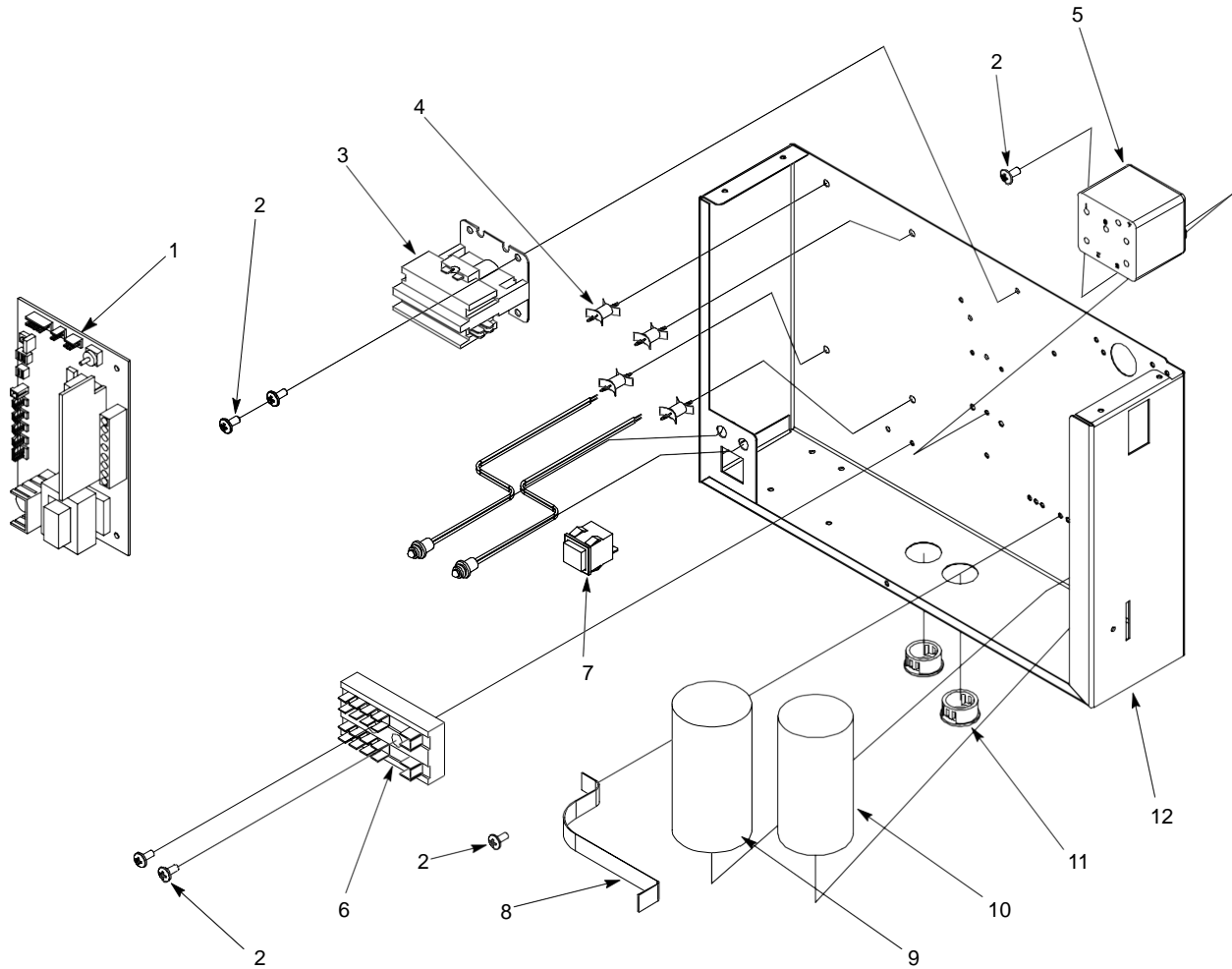

FIGURE 8. ELECTRICAL BOX ASSEMBLY

Item No.	Part No.	Name
1	630900789	Control Board
2	07578	Thread Cutting Screw, Phil Truss Hd, No. 8-32 By 3/8-In. Long
3	40713 630901104	Relay, 208/240V 50/60HZ (1444) Relay, 208/240V 50/60HZ (1844)
4	630460105	Spacer, Control Board
5	630901013 41042 161998018	Relay, Start 230V 60HZ (1444) Relay, Start 230V 50HZ (1444) Relay, Start 60HZ (1844)
6	161838002	Terminal Block
7	630900905	Switch

Item No.	Part No.	Name
8	630200166	Strap, Capacitor
9	630901016 161192005 161192011	Capacitor Run 440V 60HZ (1444) Capacitor Run 330V 50HZ (1444) Capacitor Run 440V 60HZ (1844)
10	630900730 630900176 41044	Capacitor, Start 60HZ (1444) Capacitor, Start 50HZ (1444) Capacitor, Start (1844)
11	03611	Bushing
12	630201035 630201233 630201246	Wrap, Electrical Box (1444) Wrap, Electrical Box (1844) Wrap, Electrical Box (Marine)



XTREME ICE MAKER (1444 AND 1844 SERIES)

Item No.	Part No.	Name
1	630900883	Plug
2	630900780	Distributor, Water, Inner
3	630900809	O-Ring, .075 I.D.
4	630900779	Distributor, Water, Inner, Barb
5	630900777	Distributor Ass'y, Water

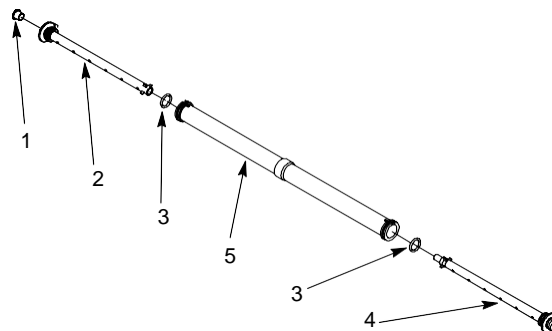

FIGURE 9. WATER DISTRIBUTOR ASSEMBLY

Item No.	Part No.	Name
1	630900881	Tube, Pump to Dump Valve
2	630900796	Pump, Water, 240V 50/60HZ
3	630900980	Tube, Pump to Distributor
4	163242002	Clamp

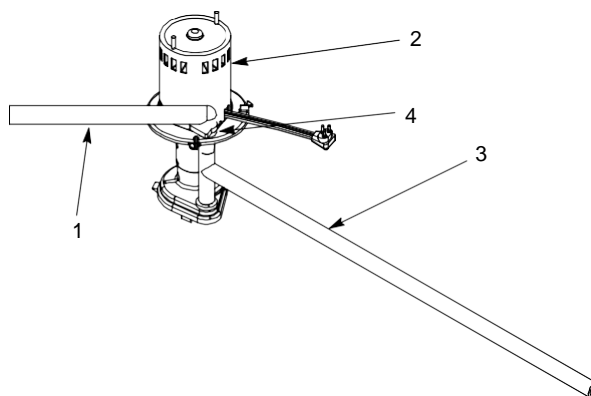

FIGURE 10. WATER PUMP ASSEMBLY

Item No.	Part No.	Name
1	630201301	Cover, Front
2	630901103	Cap, Front Panel
3	630201018	Rail, Front Panel, Left
4	630201020	Rail, Front Panel, Right

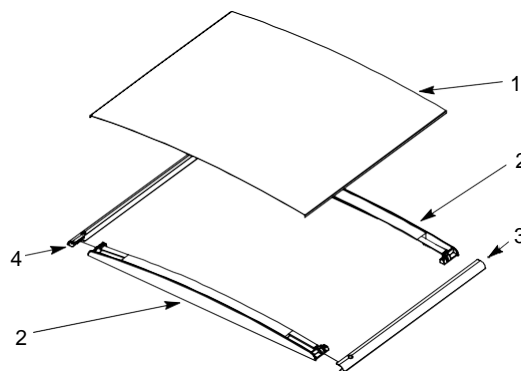

FIGURE 11. FRONT PANEL ASSEMBLY