



IMI CORNELIUS INC.
One Cornelius Place
Anoka, MN. 55303-6234
Telephone 1-800-238-3600
Facsimile 1-800-258-0255

www.cornelius.com

ILLUSTRATED PARTS LIST

XTREME ICE MAKER (1230 SERIES)

MODEL NO.

631812001
631812002
631812003
631812004
631812020
631812040
631812041

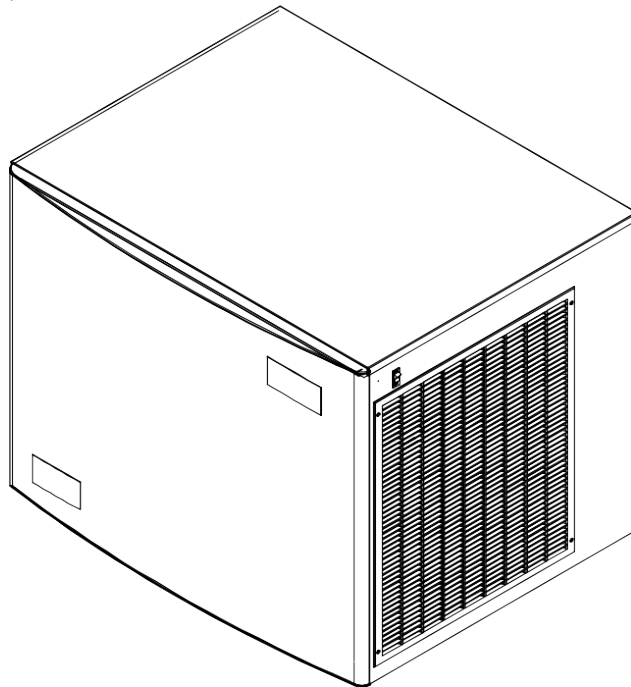



IMI CORNELIUS INC.
 One Cornelius Place
 Anoka, MN. 55303-6234
 Telephone 1-800-238-3600
 Facsimile 1-800-258-0255

www.cornelius.com

ILLUSTRATED PARTS LIST

XTREME ICE MAKER (1230 SERIES)

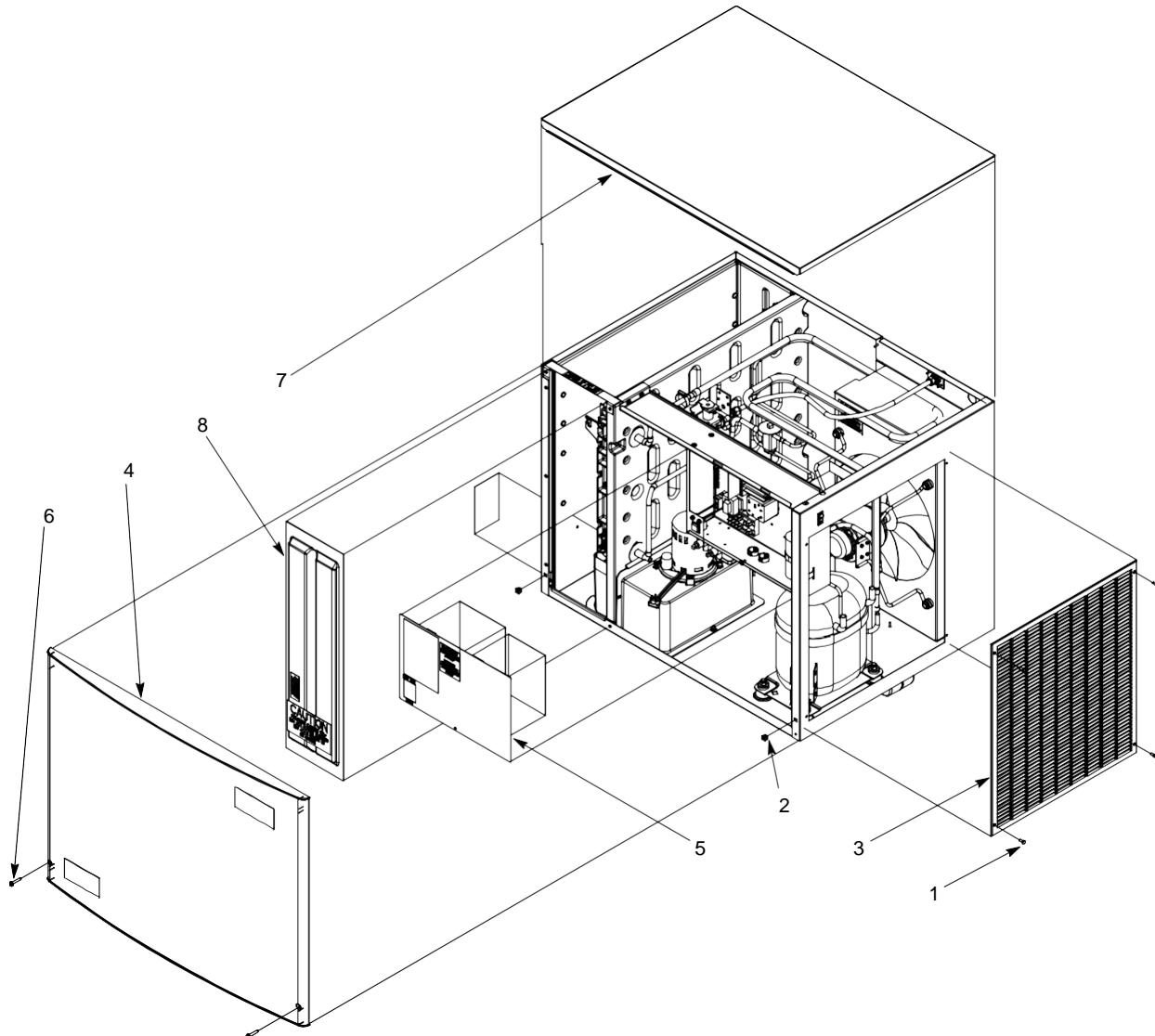

FIGURE 1. GENERAL ASSEMBLY (AIR CONDENSER SHOWN)

Item No.	Part No.	Name
1	161168006	Screw TC 8-32 HXWS 12
	161090000	Screw TC 8-32 HXWS 10 (Marine)
2	164510000	Grommet Nut
3	166194001	Grille
	630200510	Grille (Marine)
4	631500136	Front Panel Ass'y (See Figure 11)
	167979015	Panel Fnt (Marine) (See Figure 11)

Item No.	Part No.	Name
5	630201041	Cover, Electrical Box
	630201247	Cover, Electrical Box (Marine)
6	318308000	Screw TR 10-32 PAPH 32
	161168009	Screw MA 10-32 HX 48 (Marine)
7	630201049	Cover, Top
	630000890	Cover, Top (Marine)
8	630900887	Splash Panel



IMI CORNELIUS INC.
 One Cornelius Place
 Anoka, MN. 55303-6234
 Telephone 1-800-238-3600
 Facsimile 1-800-258-0255

www.cornelius.com

ILLUSTRATED PARTS LIST

XTREME ICE MAKER (1230 SERIES)

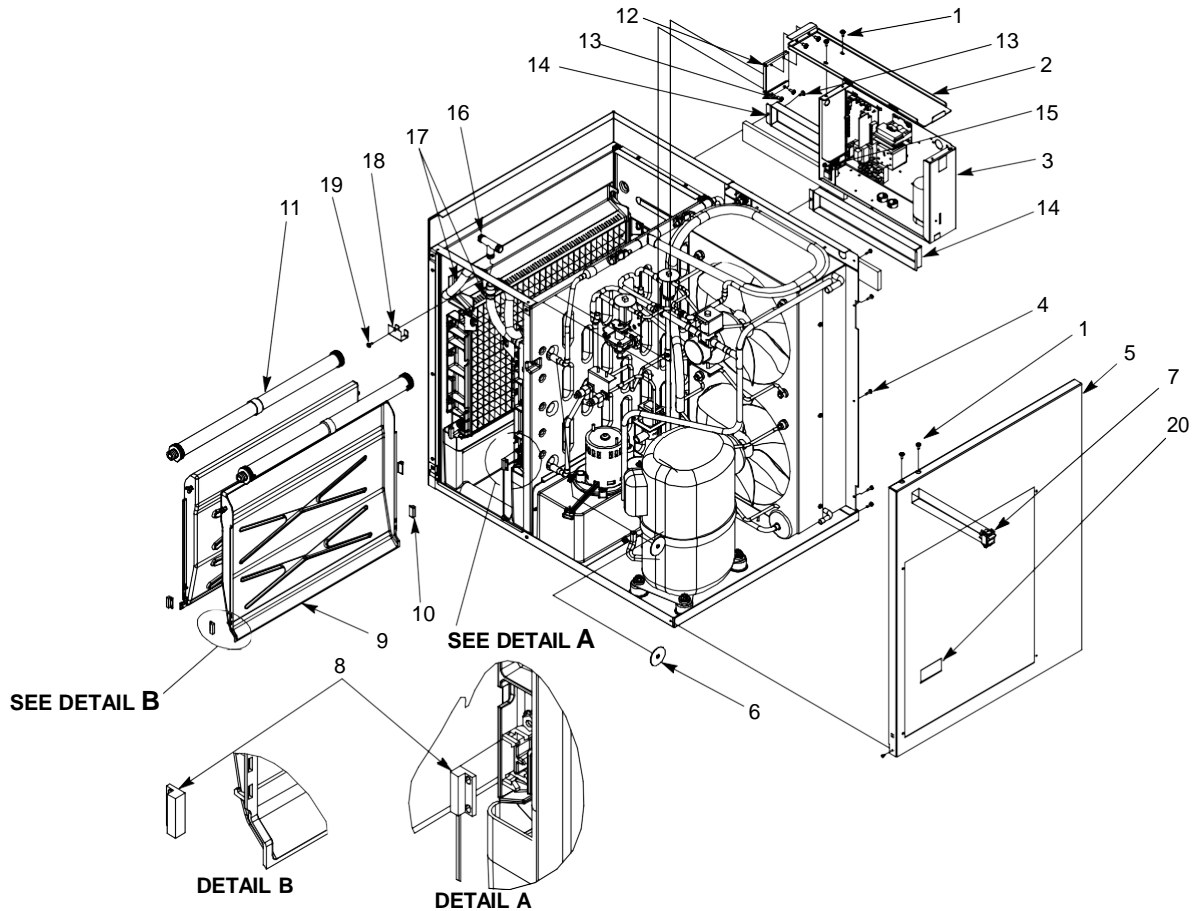

FIGURE 2. TRIM ASSEMBLY (AIR CONDENSER SHOWN)

Item No.	Part No.	Name
1	07578	Thread Cutting Screw, Phil Truss Hd, No. 8-32 By 3/8-In. Long
2	630201039	Brace, Electrical Box
3		Electrical Box Ass'y (See Figure 8)
4	165384000	Sheet Metal Screw, No. 8 By 1/2-In. Long
5	630201197	Panel, Side
6	630900893	Washer, .340 I.D.
7	630900924	Switch, On/Off
8	630900798	Switch, Proximity
9	630900828	Cover, Evaporator, Large
10	630900870	Fitting, Placeholder

Item No.	Part No.	Name
11	631500120	Water Distributor Ass'y (See Figure 9)
12	630201206	Spacer, Brace, Electrical Box
13	164126000	Screw
14	630201171	Recess Panel
15	00311	Grommet
16	00987	Fitting
17	630900818	Tube, Vynl Mold
18	630201093	Bracket, Vynl Tube
19	164713001	Screw
20	162445002	Clip



IMI CORNELIUS INC.
 One Cornelius Place
 Anoka, MN. 55303-6234
 Telephone 1-800-238-3600
 Facsimile 1-800-258-0255

www.cornelius.com

ILLUSTRATED PARTS LIST

XTREME ICE MAKER (1230 SERIES)

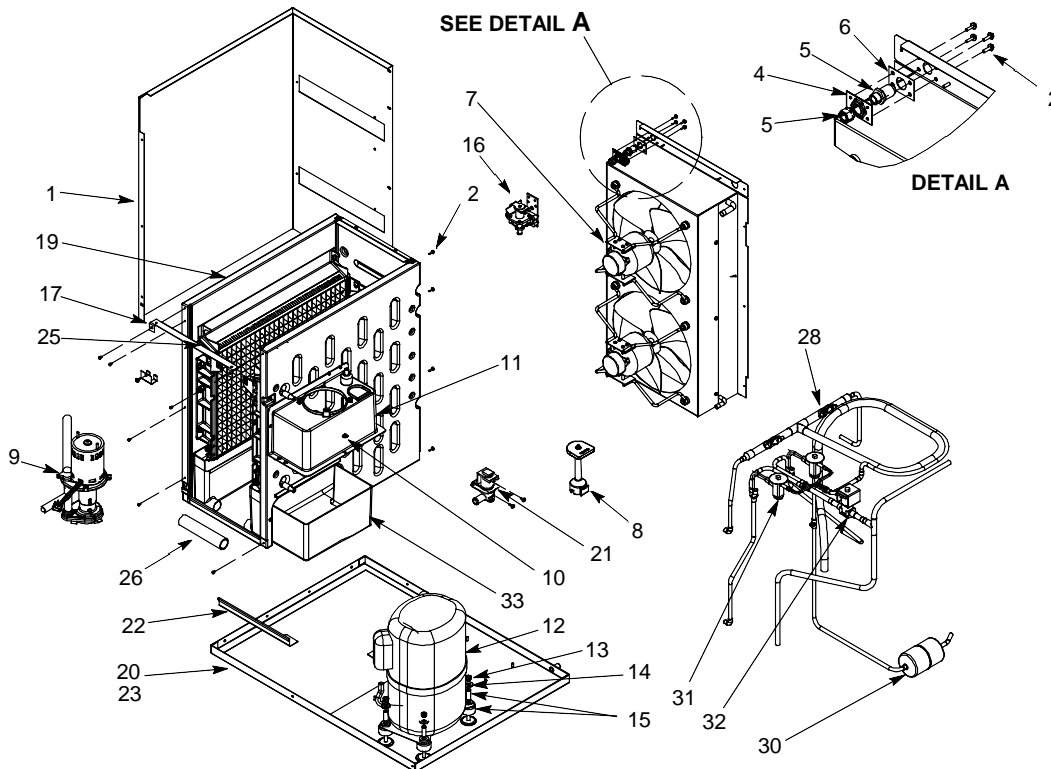

FIGURE 3. BUILD ASSEMBLY (AIR CONDENSER)

Item No.	Part No.	Name
1	630201198	Wrap, Cabinet
2	165384000	Sheet Metal Screw, No. 8 By 1/2"
3	420906000	Tube, .265 I.D. (Not Shown)
4	630200935	Flange, Bulkhead
5	630900783	Fitting, Bulkhead
6	630201072	Flange, Bulkhead
7		Condenser Ass'y (See Figure 7)
8	630900868	Pressure Sensor Ass'y
9		Water Pump Ass'y (See Figure 10)
10	630900895	Hex Nut, No. 8-32
11	630900869	Pan, Water Wrap
12	161456016	Kit Compressor, 240V 60HZ
	161456050	Kit Compressor, 230V 50HZ
13	164083005	Hex Nut, 5/16-18
14	164154001	Washer, .375 I.D.
15	165596002	Sleeve and Grommet
16	630900791	Solenoid Valve
17	630201205	Brace, Bulkhead

Item No.	Part No.	Name
18	638006070	Tube, .375 I.D. (Not Shown)
19		Bulkhead Ass'y (See Figure 6)
20	164126000	Screw, SM 8 PHTR 16
21	165637009	Dump Valve
22	630201113	Bracket, Water Pan
23	630000879	Base
24	630201112	Bracket (Not Shown)
25	630201205	Clip
26	630900930	Tube, Vynl
27	161862005	Sensor Temp (Not Shown)
28	161462001	Clamp, Screw
29	630000877	Service Valve and Bracket Ass'y (Not Shown)
30	166184003	Dryer
31	161921007	Expansion Valve
32	165629008	Hot Gas Valve
33	630900833	Water Pan



IMI CORNELIUS INC.
 One Cornelius Place
 Anoka, MN. 55303-6234
 Telephone 1-800-238-3600
 Facsimile 1-800-258-0255

www.cornelius.com

ILLUSTRATED PARTS LIST

XTREME ICE MAKER (1230 SERIES)

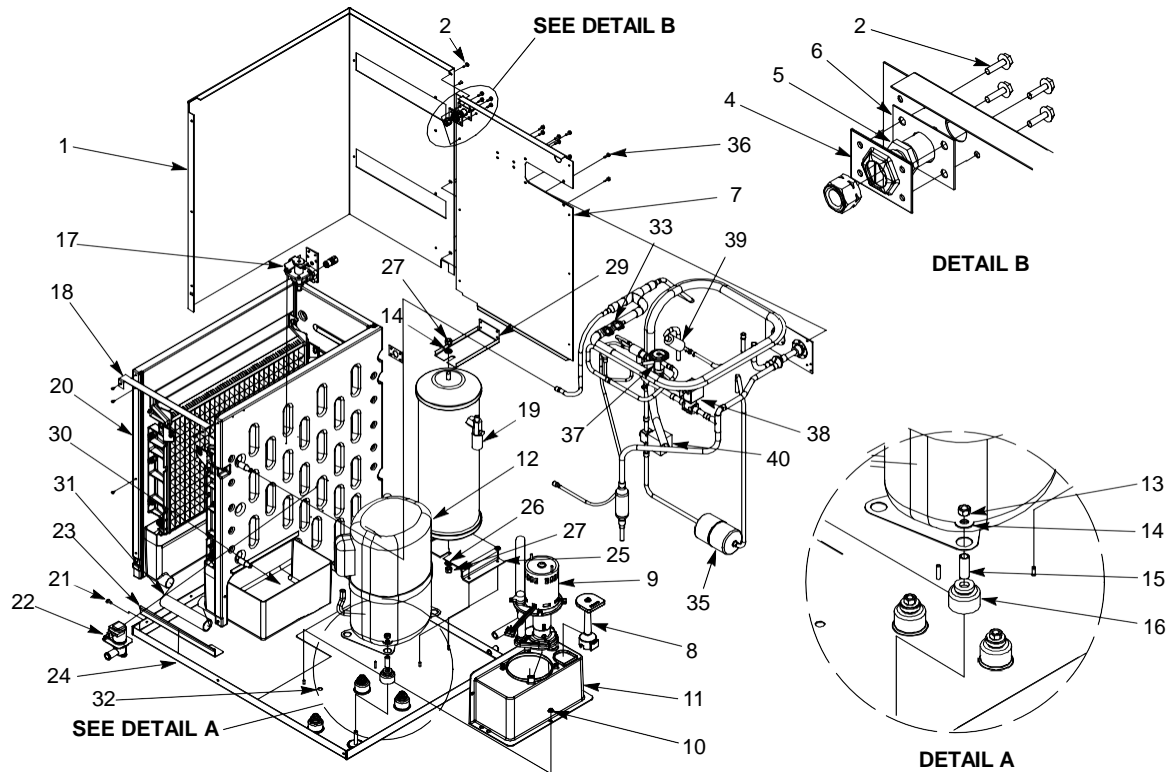

FIGURE 4. BUILD ASSEMBLY (REMOTE)

Item No.	Part No.	Name
1	630201074	Wrap, Cabinet
2	165384000	Sheet Metal Screw, No. 8 By 1/2-In. Long
3	420906000	Tube, .265 I.D. (Not Shown)
4	630200935	Flange, Bulkhead
5	630900783	Fitting, Bulkhead
6	630201072	Flange, Bulkhead
7	630201110	Panel, Back
8	630900868	Pressure Sensor Ass'y
9		Water Pump Ass'y (See Figure 10)
10	630900895	Hex Nut, No. 8-32
11	630900869	Pan, Water, Wrap
12	631500147	Compressor, 240V 60HZ
13	164083005	Hex Nut, 5/16-18
14	164154001	Washer, .375 I.D.
15	630900964	Sleeve, Grommet
16	630900963	Grommet
17	630900791	Solenoid Valve
18	630201038	Brace, Bulkhead
19	166225000	Receiver
20		Bulkhead Ass'y (See Figure 6)

Item No.	Part No.	Name
21	164126000	Sheet Metal Screw, Phil Truss Hd, No. 8 By 1/2-In. Long
22	165637009	Dump Valve
23	630201086	Bracket, Water Pan
24	630000795	Base
25	164820914	Mounting Plate, Receiver
26	01022	Washer
27	09652	Hex Nut
28	630201112	Bracket (Not Shown)
29	164820913	Bracket, Receiver Top
30	630900833	Water Pan
31	630900930	Tube, Vynl
32	300098000	Button Plug
33	161426001	Clamp
34	630000798	Service Valve and Bracket Ass'y
35	166184003	Dryer
36	165384000	Screw
37	630901024	Expansion Valve
38	165629008	Hot Gas Valve
39	165677008	Switch Ass'y
40	165629011	Solenoid Valve



IMI CORNELIUS INC.
 One Cornelius Place
 Anoka, MN. 55303-6234
 Telephone 1-800-238-3600
 Facsimile 1-800-258-0255

www.cornelius.com

ILLUSTRATED PARTS LIST

XTREME ICE MAKER (1230 SERIES)

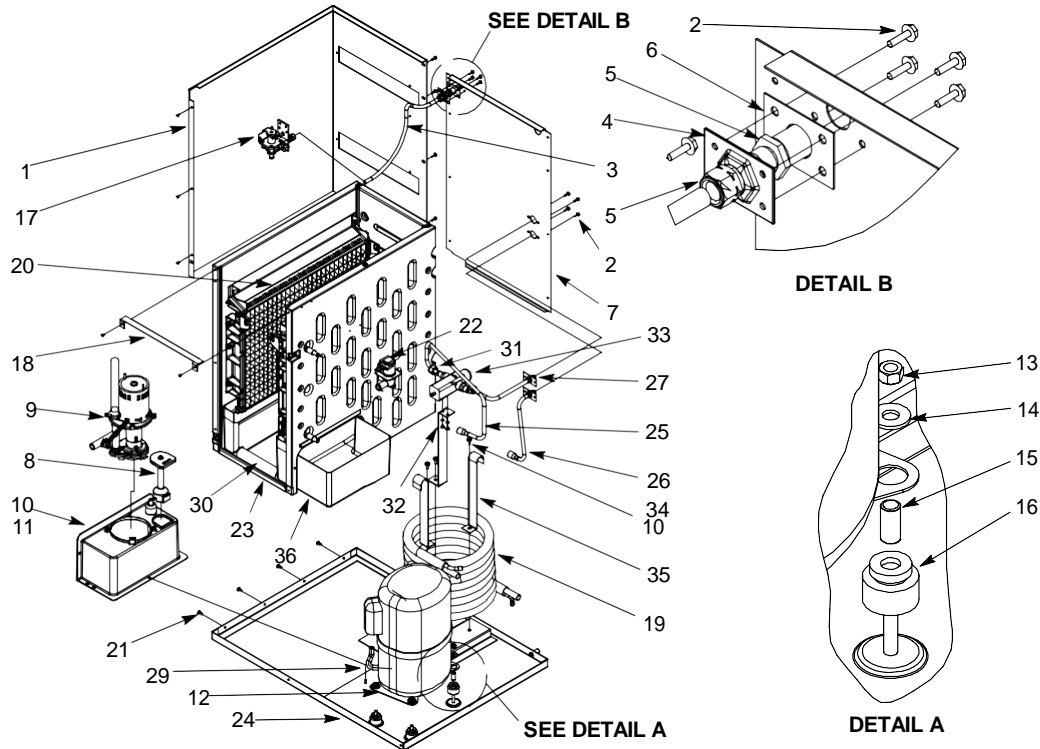

FIGURE 5. BUILD ASSEMBLY (WATER COOLED)

Item No.	Part No.	Name
1	630201074	Wrap, Cabinet
2	165384000	Screw SM 8 HX 16
	161090000	Screw TC 8-32 HXWS 10 (Marine)
3	420906000	Tube, .265 I.D.
4	630200935	Flange, Bulkhead
5	630900783	Fitting, Bulkhead
6	630201072	Flange, Bulkhead
7	630201089	Panel, Back
	630000891	Panel, Back (Marine)
8	630900868	Pressure Sensor Ass'y
9		Water Pump Ass'y (See Figure 10)
10	630900895	Hex Nut, No. 8-32
11	630900869	Pan, Water, Wrap
12	631500147	Compressor, 240V 60HZ
13	164083005	Hex Nut, 5/16-18
	164083006	Hex Nut, 5/16-18 (Marine)
14	164154001	Washer, .375 I.D.
	164154002	Washer Ft .312 I.D. (Marine)
15	630900964	Sleeve, Grommet
16	630900963	Grommet
17	630900791	Solenoid Valve

Item No.	Part No.	Name
18	630201038	Brace, Bulkhead
19	27177	Water Coil Ass'y
20		Bulkhead Ass'y (See Figure 6)
21	164126000	Sheet Metal Screw, Phil Truss Hd, No. 8 By 1/2-In. Long
22	165637009	Dump Valve
23	630201113	Bracket, Water Pan
24	630000811	Base
25	161763010	Tube Ass'y
26	164832011	Tube Ass'y, Water Inlet
27	164832010	Tube Ass'y, Water Outlet
28	630201112	Bracket (Not Shown)
29	300098000	Button Plug
30	630900930	Tube, Vynl
31	161426001	Clamp
32	00214	Washer
33	164980002	Valve, Water Regulator
34	161189000	Washer
35	166196001	Clamp, Water Coil
36	630900833	Water Pan



IMI CORNELIUS INC.
 One Cornelius Place
 Anoka, MN. 55303-6234
 Telephone 1-800-238-3600
 Facsimile 1-800-258-0255

www.cornelius.com

ILLUSTRATED PARTS LIST

XTREME ICE MAKER (1230 SERIES)

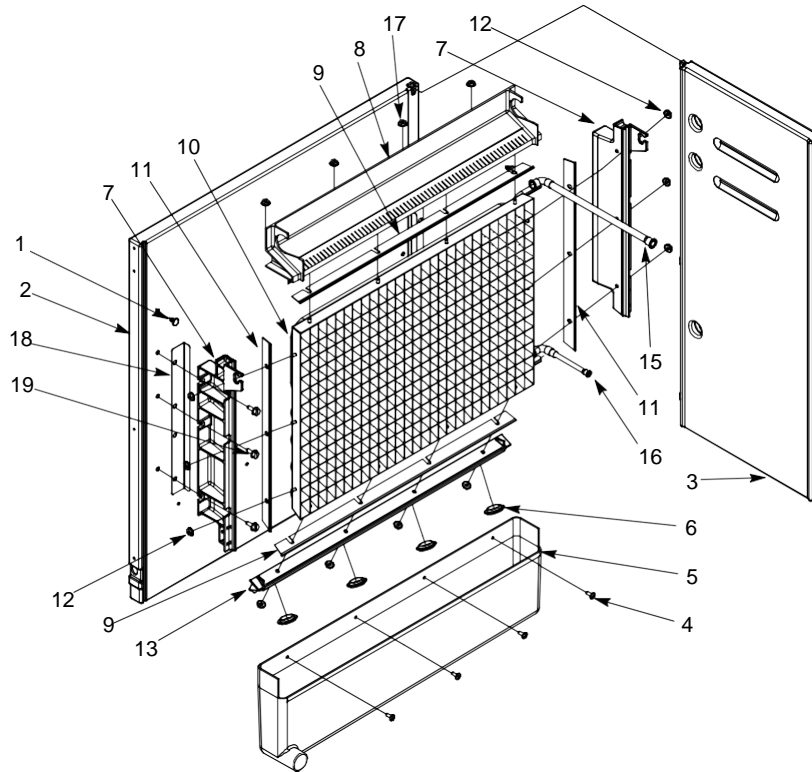

FIGURE 6. BULKHEAD ASSEMBLY

Item No.	Part No.	Name
1	630900903	Clip
2	630900847 630900899	Panel, Bulkhead Left Panel, Bulkhead, Right
3	630900844	Bulkhead, Rear
4	164126000	Sheet Metal Screw, Phil Truss Hd, No. 8 By 1/2-In. Long
5	630900833 630900835	Pan, Water, Large, Right Pan, Water, Large, Left
6	630900892	Plug
7	630900863 630900862	Frame, Evaporator, Left Frame, Evaporator, Right
8	630900781	Deflector, Water
9	630201024	Gasket, Frame, Top and Bottom
10	631500141 631500119	Kit Service Evap Frame Left (Standard Cube) Kit Service Evap Frame Right (Standard Cube)

Item No.	Part No.	Name
	631500142 631500137	Kit Service Evap Frame Left (Large) Kit Service Evap Frame Right (Large)
11	630201029 630201030	Gasket, Side, Left Gasket, Side, Right
12	630900895	Hex Nut, No. 8-32
13	630900857	Frame, Evaporator, Bottom
14	630900896	Sheet Metal Screw, Hex Hd, No. 14 by 5/8" (Not Shown)
15	630000829 630250120	Evaporator Line, Upper, Left Evaporator Line, Upper, Right
16	630000849 630250120	Evaporator Line, Lower, Left Evaporator Line, Lower, Right
17	630900895	Nut
18	630201243	Bracket, Evaporator Frame Support
19	630900896	Screw



IMI CORNELIUS INC.
 One Cornelius Place
 Anoka, MN. 55303-6234
 Telephone 1-800-238-3600
 Facsimile 1-800-258-0255

www.cornelius.com

ILLUSTRATED PARTS LIST

XTREME ICE MAKER (1230 SERIES)

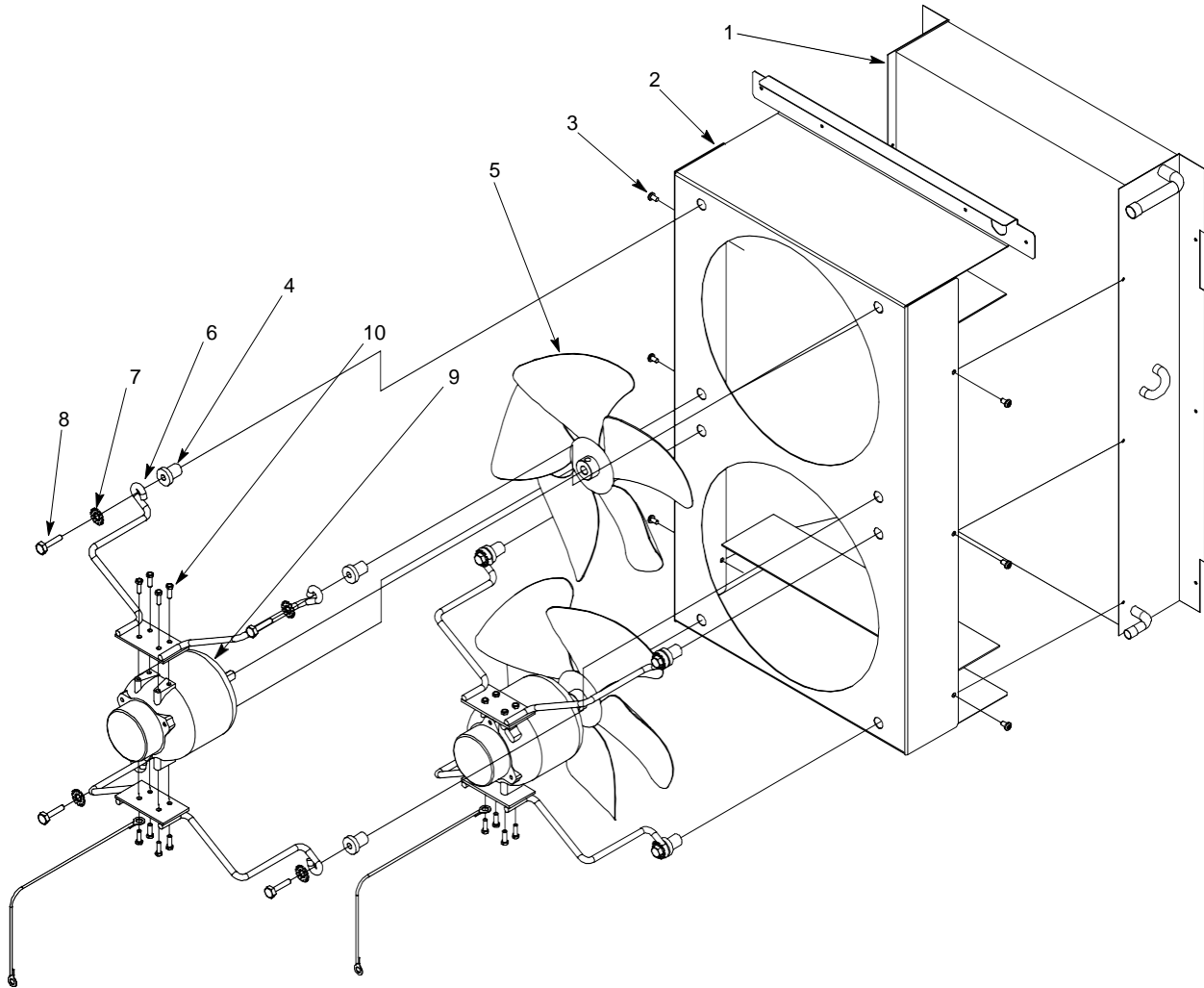

FIGURE 7. CONDENSER ASSEMBLY

Item No.	Part No.	Name
1	161870005	Condenser Coil
2	630201199	Shroud, Condenser
3	630900190	Sheet Metal Screw, Phil Pan Hd, No. 8 By 3/8-In. Long
4	630900889	Well Nut, 1/4-20
5	630900309	Fan Blade
6	630900919	Bracket, Motor

Item No.	Part No.	Name
7	23978	Washer, .690 I.D.
8	165294000	Machine Screw, Hex Hd, 1/4-20 By 1-In. Long
9	166181011	Motor Cond 230V 50HZ
	630900308	Motor Cond 240V 60HZ
10	03612	Machine Screw, Hex Hd, No. 8-36 By 1/2-In. Long



IMI CORNELIUS INC.
 One Cornelius Place
 Anoka, MN. 55303-6234
 Telephone 1-800-238-3600
 Facsimile 1-800-258-0255

www.cornelius.com

ILLUSTRATED PARTS LIST

XTREME ICE MAKER (1230 SERIES)

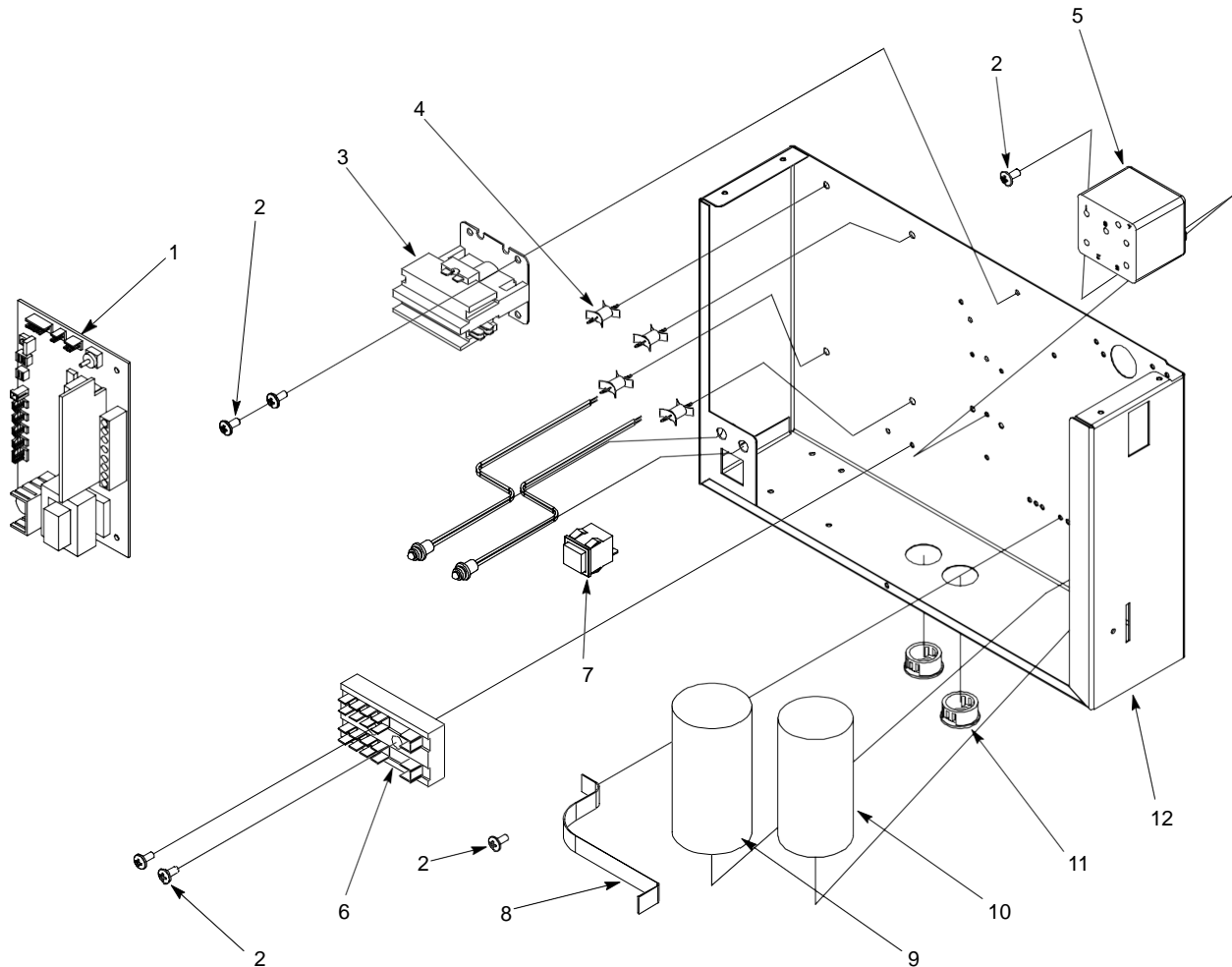

FIGURE 8. ELECTRICAL BOX ASSEMBLY

Item No.	Part No.	Name
1	630900789	Control Board
2	07578	Thread Cutting Screw, Phil Truss Hd, No. 8-32 By 3/8-In. Long
3	40713	Relay, 208/240V 50/60HZ
4	630460105	Spacer, Control Board
5	638090242	Relay, Start 230V 50HZ
	40285	Relay, Start (Air)
	630900965	Relay, Start (Remote and Water)
6	161838002	Terminal Block
7	630900905	Switch
8	630200166	Strap, Capacitor

Item No.	Part No.	Name
9	161192005	Capacitor, Run 240V 50/60HZ (Air)
	630900967	Capacitor, Run (Remote and Water)
10	41044	Capacitor, Start (Air)
	630901026	Capacitor, Start (Remote and Water)
	161165013	Capacitor, Start 230V 50HZ
11	03611	Bushing
12	630201035	Wrap, Electrical Box
	630201246	Wrap, Electrical Box (Marine)



XTREME ICE MAKER (1230 SERIES)

Item No.	Part No.	Name
1	630900883	Plug
2	630900780	Distributor, Water, Inner
3	630900809	O-Ring, .075 I.D.
4	630900779	Distributor, Water, Inner, Barb
5	630900777	Distributor Ass'y, Water

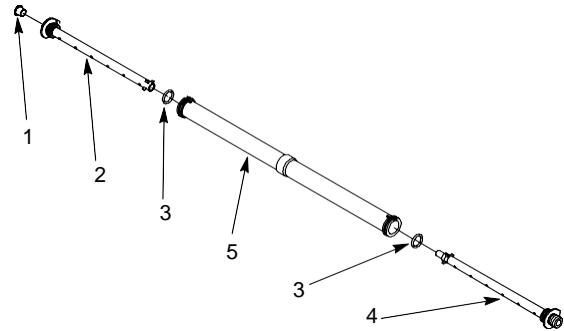

FIGURE 9. WATER DISTRIBUTOR ASSEMBLY

Item No.	Part No.	Name
1	630900881	Tube, Pump to Dump Valve
2	630900796	Pump, Water, 240V 50/60HZ
3	630900980	Tube, Pump to Distributor
4	163242002	Clamp

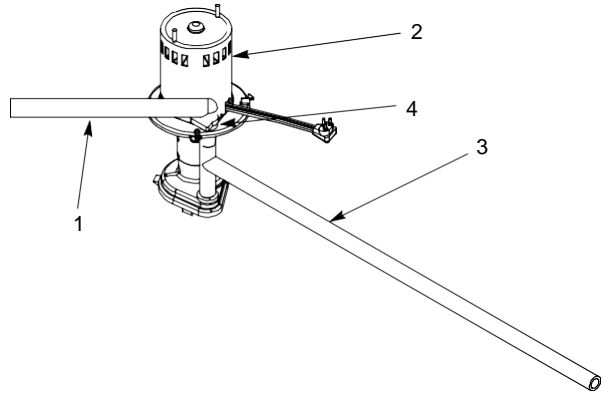

FIGURE 10. WATER PUMP ASSEMBLY

Item No.	Part No.	Name
1	630201200	Cover, Front
2	630900853	Cap, Front Panel
3	630201201	Rail, Front Panel, Left
4	630201202	Rail, Front Panel, Right

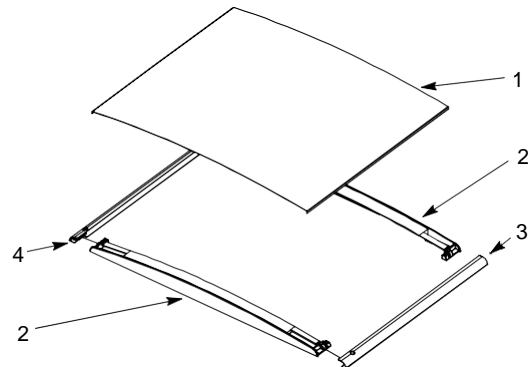

FIGURE 11. FRONT PANEL ASSEMBLY