

PRESS KIT

MODEL No: DHPK34

INSTRUCTION MANUAL

CONTACT

Seattle, WA 98105
United States

help@dulytek.com
www.dulytek.com

© Dulytek
All rights reserved



TABLE OF CONTENTS

PAGE 2	INTRODUCTION Read Before Operating Machinery Copyright Notice Disclaimer
PAGE 2	SAFETY PRECAUTIONS
PAGE 4	HANDLING PRECAUTIONS
PAGE 5	UNPACKING Unpacking Precautions Unpacking Instructions Item Checklist Required Equipment Recommended Parts
PAGE 6	GETTING FAMILIAR DHPK34 Press Kit Features and Controls
PAGE 7	OPERATING INSTRUCTIONS Preparing and Starting Press Kit Setting Control Panel Pressing Turning Off Press Kit Cleaning Press Plates
PAGE 11	TECHNICAL SPECIFICATIONS

INTRODUCTION

DULYTEK DHPK34 heat plates press kit is engineered and manufactured as a retrofit solution for converting a standard H-frame (A-frame) hydraulic work shop press into a heat press machine.

**READ BEFORE
OPERATING
MACHINERY**

To avoid accidents, first read SAFETY PRECAUTIONS (PAGE 2) and HANDLING PRECAUTIONS (PAGE 4).

Read this manual carefully to ensure you use the press kit correctly. After reading and familiarizing yourself with the equipment, store the manual in a safe place for future references.

**COPYRIGHT
NOTICE**

Copyright © by DULYTEK. All rights reserved. No part of this document may be reproduced, distributed, or transmitted in any form or by any means, including photocopying, recording, or other electronic or mechanical methods, without the prior written consent of the company. Product design, logos, brand names for various media, and product photos are the sole and exclusive property of DULYTEK.

DISCLAIMER

This unit is intended for LEGAL use only, in accordance with your federal, state, and local laws, ordinances, and regulations.

Please keep this manual in a safe place for future references.

SAFETY PRECAUTIONS

The following precautions are provided to prevent harm or injury to yourself and others. Please make sure to thoroughly read, understand, and follow these precautions before using the product.

SAFETY PRECAUTIONS

If product is damaged, appears to be damaged, or malfunctions, contact DULYTEK customer service at help@dulytek.com.

WARNING: Follow the warnings below. Otherwise, death or serious injuries may occur.



- Use this product only as described in this manual.
- Keep the equipment out of the reach of children at all times.
- Unplug the heat press from the electrical outlet and let it cool down COMPLETELY before cleaning, performing maintenance, or repair.
- DO NOT operate the product after the appliance malfunctions or is dropped or damaged in any way.
- DO NOT operate the press if the plates are dirty. Clean the plates with isopropyl alcohol and wipe them dry with a clean cloth. Ensure both plates are completely dry before use.
- DO NOT immerse the press, its power cord, and plugs in water or any other liquid.
- DO NOT place the product on or near a hot gas or electric burner, heated oven, or any other heat source.
- DO NOT operate the product with a damaged cord or plug.
- DO NOT leave any cords near a heat source. It can deform the cord or melt its insulation causing electrical shock or fire.
- Always insert the power plug all the way in.
- DO NOT handle a power plug or other components of the press with wet hands.
- When unplugging a power cord, grasp and pull with the plug instead of the cord.
- DO NOT scratch, cut, twist, excessively bend, or tie the cord or put a heavy object on it.
- DO NOT let the power cord drape over the countertop or tabletop, where it can be accidentally tripped over or pulled on.
- DO NOT connect too many power plugs to the same power outlet.
- DO NOT cover the press with a cloth. Doing so may trap heat within and cause fire.
- Remove dust around the plug and power cord with a clean dry cloth. If the

SAFETY PRECAUTIONS (continued)

- surrounding is dusty, humid, or oily, short-circuit may occur, causing a fire.
- DO NOT remove the machine cover.
- DO NOT disassemble the press or make any modifications to the equipment.

HANDLING PRECAUTIONS



- The press must be operated on a hard, level surface, away from its edges to prevent accidental tipping over.
- Work area must be kept clean, tidy, and free of obstructions to the press moving parts.
- Always attach the power cord to the press first, then plug it into the wall outlet.
- To unplug the press, turn OFF the power switch, only then remove the plug from the outlet.
- DO NOT touch the press's hot surfaces. Use heat-resistant gloves or tools. Care must be exercised as serious burns can occur from touching hot platens.
- Keep your hands and other body parts away from the moving parts to prevent injury.



- This press comes with a power cord that fits into a standard household 3-prong outlet (110V American market and 220V European market). DO NOT attempt to use the equipment with a two-prong electrical cord or any other way without proper grounding.
- DO NOT exceed the rated capacity.
- Contact DULYTEK at help@dulytek.com if the equipment does not start or if smoke or unusual odors are detected.
- Always turn the machine OFF and unplug it when done using.

UNPACKING

UNPACKING PRECAUTIONS

WARNING: Keep the packaging materials (cardboard, foam, plastic bags, etc.) out of the reach of children to prevent accidental choking, suffocation, strangulation, and other injury.

Preserve the shipping carton. DO NOT discard or disassemble the shipping box. It is designed to hold the weight of the product and should be used in case you need to return the equipment for repair or warranty maintenance in the future. DO NOT attempt to ship the product in a different container.

UNPACKING INSTRUCTIONS

1. Place the box on a large, sturdy, flat surface.
2. Open the box and remove the instruction manual and all parts that came with the press kit.
3. Remove the packaging material and carefully lift the plate unit and the controller out of the box.
4. Remove any protective or promotional labels from the plate unit and other parts if applicable.
5. Examine the kit after unpacking for any damage. If found one, take a picture and contact DULYTEK at help@dulytek.com immediately.

ITEM CHECKLIST

Before starting, please make sure that the following items are included with your DHPK34 press kit. If anything is missing, contact DULYTEK.

1. DULYTEK heating plate unit with the connecting cable;
2. DULYTEK controller;
3. AC Power Cord;
4. Instruction Manual.

REQUIRED EQUIPMENT

The DHPK34 press kit must be used together with a standard 3 to 15 Ton hydraulic or pneumatic work shop press (up to 2.16 in / 55 mm ram diameter).

RECOMMENDED PARTS The following items are recommended for use with this machine:

Seattle, WA 98105
United States

help@dulytek.com
www.dulytek.com

© Dulytek
All rights reserved

UNPACKING (continued)

- RECOMMENDED PARTS (continued)**
1. Parchment paper sheets;
 2. Silicone mat (optional);
 3. Filter bags (optional);
 4. Pre-press mold (optional);
 5. Humidity packs (optional);
 6. Collection tools, glass stamp, etc.

Please see PRESSING TIPS (<https://bit.ly/2YuM8pR>) for more information.

GETTING FAMILIAR

DHPK34 PRESS KIT FEATURES AND CONTROLS

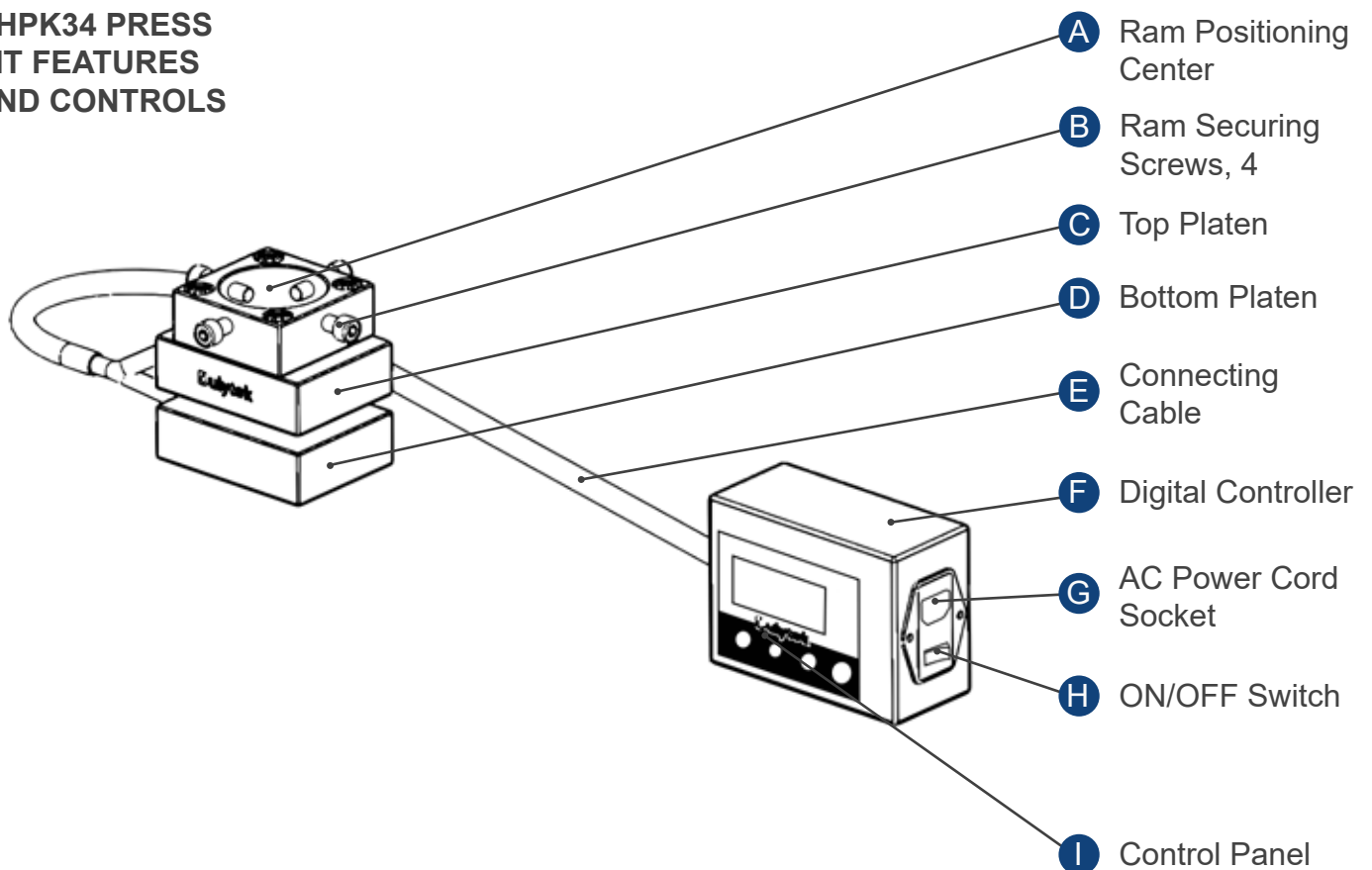

OPERATING INSTRUCTIONS

PREPARING PRESS KIT

1. Prepare materials you wish to press. Please see PRESSING TIPS (<https://bit.ly/2YuM8pR>) for more information.
2. Make sure all switches and controls of the press kit are turned off.
3. Insert the AC power cord that came with the product into the controller AC power cord socket **G** and then plug its other end into an electrical outlet (110V USA / 220V EUR).
4. Line the press arbor plates with a silicone mat, if used.
5. Position the top and the bottom platens, **C** and **D**, on top of the mat, if used, or directly on the arbor plates and align them with the center of the ram.
6. Lower the ram shaft carefully, re-aligning the platens if necessary, until the ram end is fully inserted into the ram positioning center **A**.
7. Secure the top platen **C** around the ram shaft by tightening the four screws **B**.
8. Lift up the ram shaft to create a necessary space between the platens for your material.
9. Position the digital controller **F** on a sturdy, easily reachable surface. Tip: The controller's magnetic feet will attach to any metal surface, horizontal or vertical, such as the press frame or a side of the press apron. Make sure the control panel **I** and ON/OFF switch **H** are easily accessible.
10. Flip the ON/OFF switch **H** on the controller. The control panel **I** lights up.

SETTING CONTROL PANEL

The control panel **I** is used to set temperature, temperature scale, and timer. In a regular operating mode, the display's top two lines show the current temperature of the upper and lower platens and the bottom line - the set time. Please follow the steps below to record the desired settings:

1. Press SET button on the control panel (Fig. 1) to go to the temperature setting mode for the top platen.
2. Press Up **▲** or Down **▼** buttons to select the desired temperature (Fig. 2). The selected temperature is shown on the upper **U** line of the display. Tip: Enter the temperature either in °F or °C; you will be able to select the temperature scale later.

OPERATING INSTRUCTIONS (continued)

SETTING CONTROL PANEL (continued)



Fig. 1



Fig. 2



Fig. 3

3. Press SET button again (Fig. 3) to go to the temperature setting mode for the bottom platen.
4. Press Up (▲) or Down (▼) buttons to select the desired temperature (Fig. 4). The selected temperature is shown on the lower line [L] of the display.
5. Press SET button again (Fig. 5) to go to the timer setting mode.



Fig. 4



Fig. 5



Fig. 6

6. Press Up (▲) or Down (▼) buttons to select the desired time in seconds (Fig. 6).
7. Press SET button to go to the temperature scale selection mode (Fig. 7).
Tip: Depending on your machine's default settings, you may either see "F" or "C" on the display indicating the currently selected temperature scale (°F or °C).
8. Press Up (▲) or Down (▼) buttons to select either °F or °C (Fig. 8) OR skip this step if you are satisfied with the current selection.
9. Press SET button once more (Fig. 9) to record all control panel's settings.

OPERATING INSTRUCTIONS (continued)

SETTING CONTROL PANEL (continued)



Fig. 7



Fig. 8



Fig. 9

The platens start heating, and the heating icons are now displayed on the screen (Fig. 10).



Fig. 10



Fig. 11



Fig. 12

PRESSING

1. Wait until the platens reach the desired temperature(s) (Fig. 11). Tip: Once heating is finished, the heating icons are turned off.
2. Position the material you wish to press in the center of the bottom platen **D** exercising extreme caution since it is hot.
3. Activate the press, lowering the ram with the attached top platen **C**. Continue lowering the ram until you reach the desired pressure between the platens.
4. Press TIMER button on the control panel to start the countdown (Fig. 12). The timer icon and countdown are now shown on the lower line of the display.
5. Wait until the countdown ends and the press starts beeping.
6. Press TIMER button again to turn off the timer and stop beeping.

OPERATING INSTRUCTIONS (continued)

PRESSING (continued)

7. Carefully release the ram pressure lifting up the shaft and the top platen **C**.
8. Remove the pressed material using heat resistant gloves or tools and exercising extreme caution.

TURNING OFF PRESS KIT

1. Flip the ON/OFF switch **H** to turn off the press kit when done pressing.
2. Unplug and then disconnect the AC power cord from the press.
3. Wait until the plates cool down.
4. Loosen up the ram screws **B** and carefully detach the top platen **C** from the ram shaft.
5. Remove the controller and the plates from the press.
6. Wait until the the press kit cools down completely to clean and store it.

CLEANING PRESS PLATES

1. Make sure the press plates are completely cooled down before cleaning.
2. Apply a small amount of alcohol to a clean cloth and wipe down the plates until clean. Use rubbing alcohol that contains at least 80% by volume of isopropyl alcohol.
3. Wipe plates with a dry clean cloth.
4. Repeat these steps for cleaning all associated tools.

TECHNICAL SPECIFICATIONS

PARAMETER	USA MARKET	EU MARKET
Model	DHPK34	DHPK34-E
Press Force	3 - 15 Ton	
Power	610 W	
Current	5.6 A	2.8 A
Voltage	110 V	220 V
Frequency	50 / 60 Hz	
Dual Heating Plates	Yes	
Platen Size	3 x 4 in / 76 x 101 mm	
Ram Diameter	2.16 in / 55 mm	
Temperature Range	up to 356 °F / 180 °C	
Timer Range	0 - 999 sec	
Weight	12 lb / 5.4 kg	
Certifications	CE / RoHS	