

2" DRAIN HOLE

1 TOP VIEW

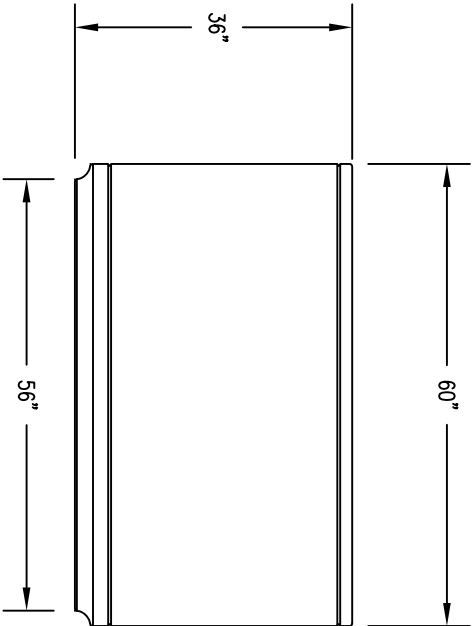

2 ELEVATION VIEW

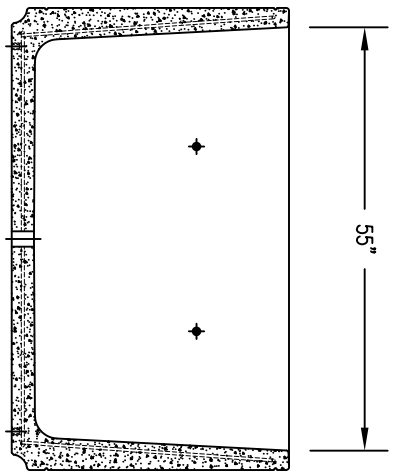

4 CROSS SECTION

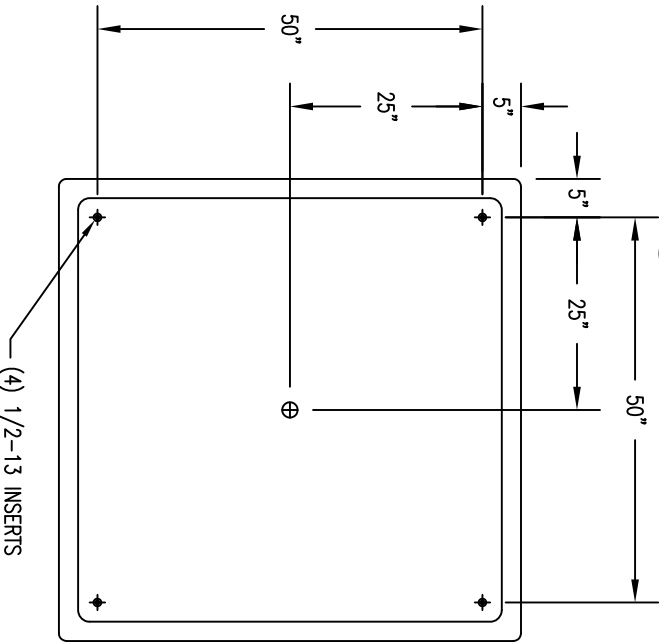

3 BOTTOM VIEW



REVISIONS

NAME	DATE	NOTES
1		
2		
3		
4		
5		
6		
7		
8		

THESE DRAWING SPECIFICATIONS AND OTHER INFORMATION ARE THE CONFIDENTIAL AND PROPRIETARY PROPERTY OF WILSON TIE, INC. THE DRAWINGS HEREIN SHALL REMAIN THE PROPERTY OF WILSON TIE, INC. ANY ADDITIONAL USE SHALL REQUIRE THE PRIOR WRITTEN APPROVAL OF WILSON TIE, INC. THE PROPRIETARY INFORMATION CONTAINED HEREIN IS THE DOMAINS AND TRADE SECRETS OF WILSON TIE, INC. THE SITE PROPERTY OF WILSON TIE, INC.

JOB NAME
ADDRESS
CITY, STATE ZIP

UNLESS OTHERWISE SPECIFIED DIMENSIONS ARE IN INCHES FRACTIONS 1/8"

DRAWN BY: SK
DATE: 7/23/15
CD NUMBER: 7
WEIGHT: 3.470 LBS

PRODUCT NO.
TF 4205