

1 TOP VIEW
SCALE 1/8"=1"

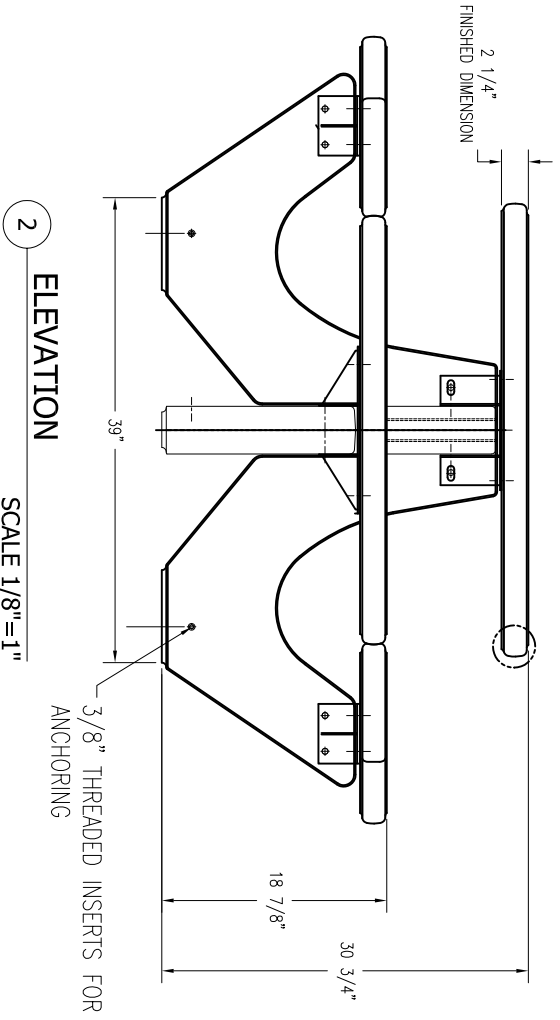

2 ELEVATION
SCALE 1/8"=1"

REVISIONS		
NAME	DATE	NOTES
1	---	---
2	---	---
3	---	---
4	---	---
5	---	---
6	---	---
7	---	---
8	---	---

CONFIDENTIAL INFORMATION
 THESE DRAWING, SPECIFICATIONS AND OTHER INFORMATION AND DOCUMENTS ACCOMPANYING THEM ARE THE PROPERTY OF WAUSAU TILE, INC. THE DRAWINGS THEMSELVES SHALL BELONG TO THE OWNER FOR USE ONLY ON THE PROJECT. ANY ADDITIONAL USE SHALL REQUIRE THE PRIOR WRITTEN APPROVAL OF WAUSAU TILE, INC. THE PROPRIETARY INFORMATION CONTAINED WITHIN THE DRAWINGS AND THE DOCUMENTS IS AND SHALL REMAIN THE SOLE PROPERTY OF WAUSAU TILE, INC



UNLESS OTHERWISE SPECIFIED
 DIMENSIONS ARE IN INCHES
 FRACTIONS ± 1/8"

DRAWN BY: TAS
 DATE: 3/8/17
 CO NUMBER: .
 WEIGHT:

APPROVED: _____
 DATE: _____

(SIGNATURE ABOVE ILLUSTRATES ACCEPTANCE OF DIMENSIONS SHOWN.)

SHEET NO.
 TF3125