

X-BRACE DETAIL
N.T.S.
 ○ 7/16" X 1" GALV. MACH. BOLT
 △ 7/16" X 1.1/2" GALV. MACH. BOLT

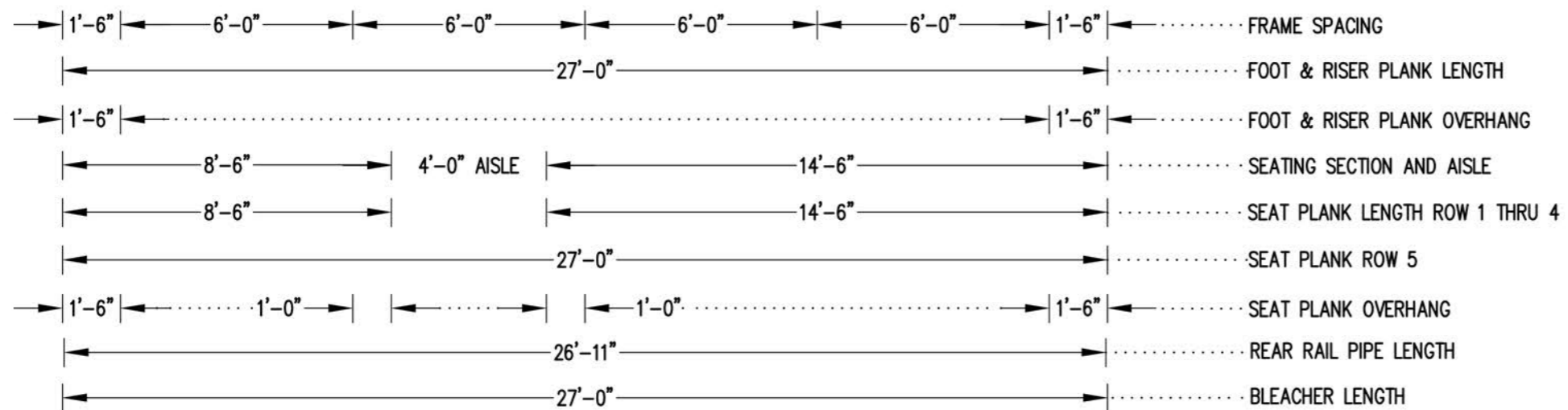

SEATING & FRAMING PLAN
 1/4" = 1'-0"
 74 NET SEAT @ 18" PER SEAT

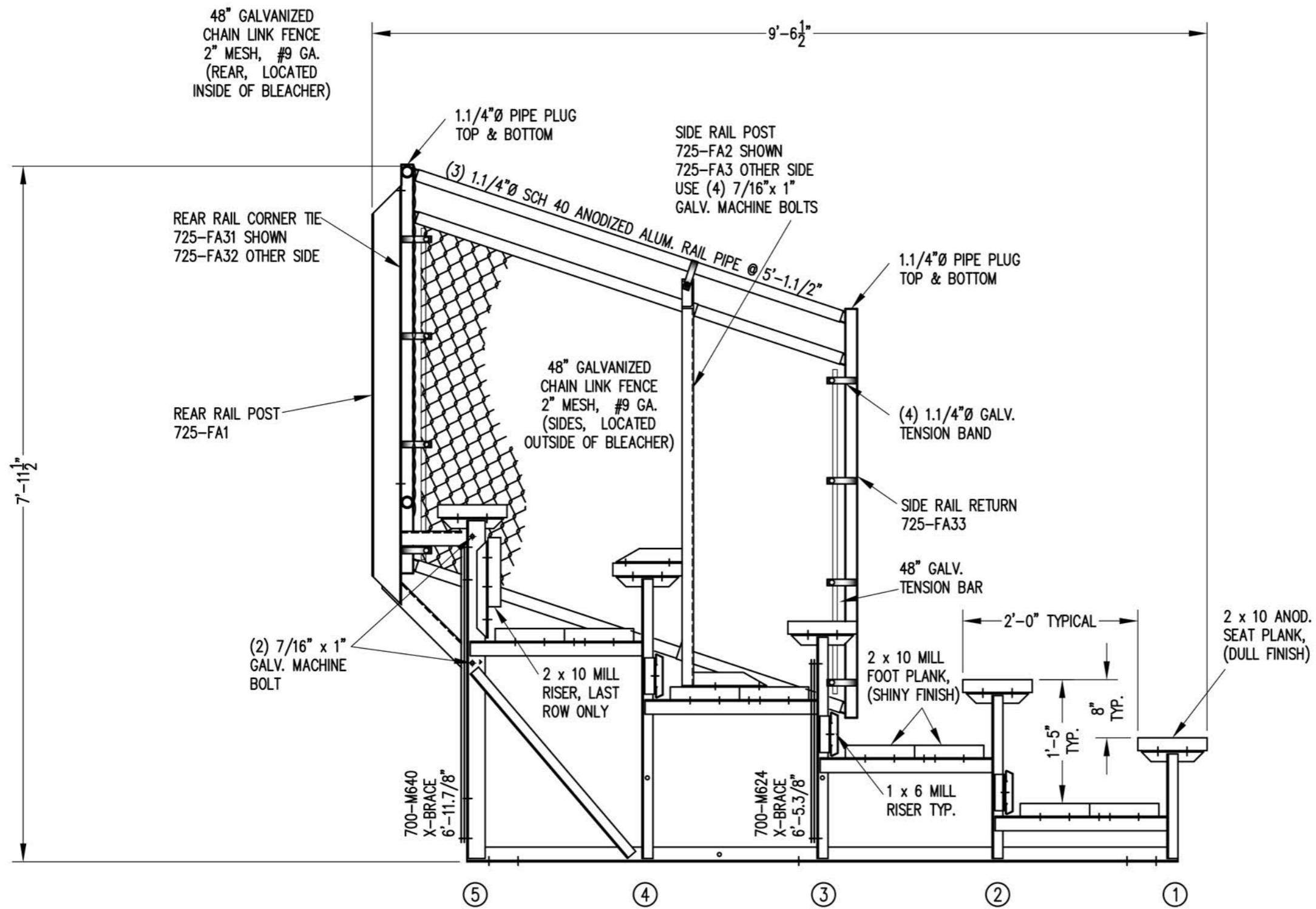

SECTION AA

3/4" = 1'-0"

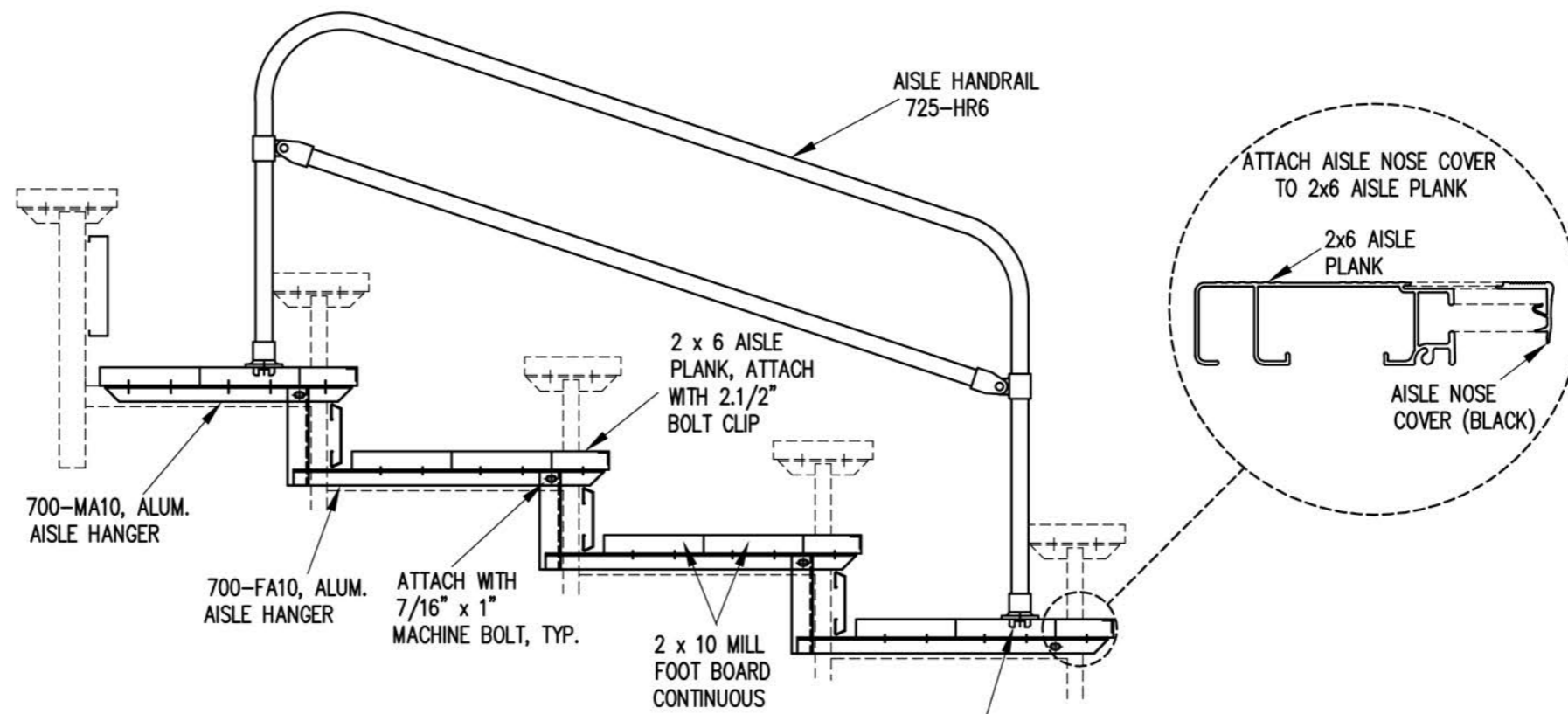

NOTE: ALL AISLE HANGERS - TWO PER
LOCATION REQUIRED, TYPICAL

SECTION BB

3/4" = 1'-0"

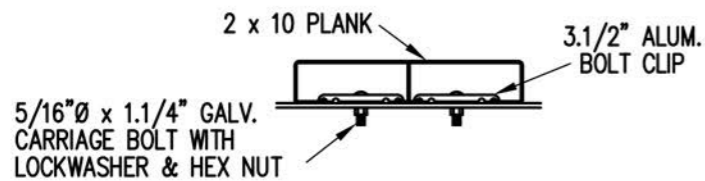

BOLT CLIP DETAIL

1.1/2" = 1'-0"

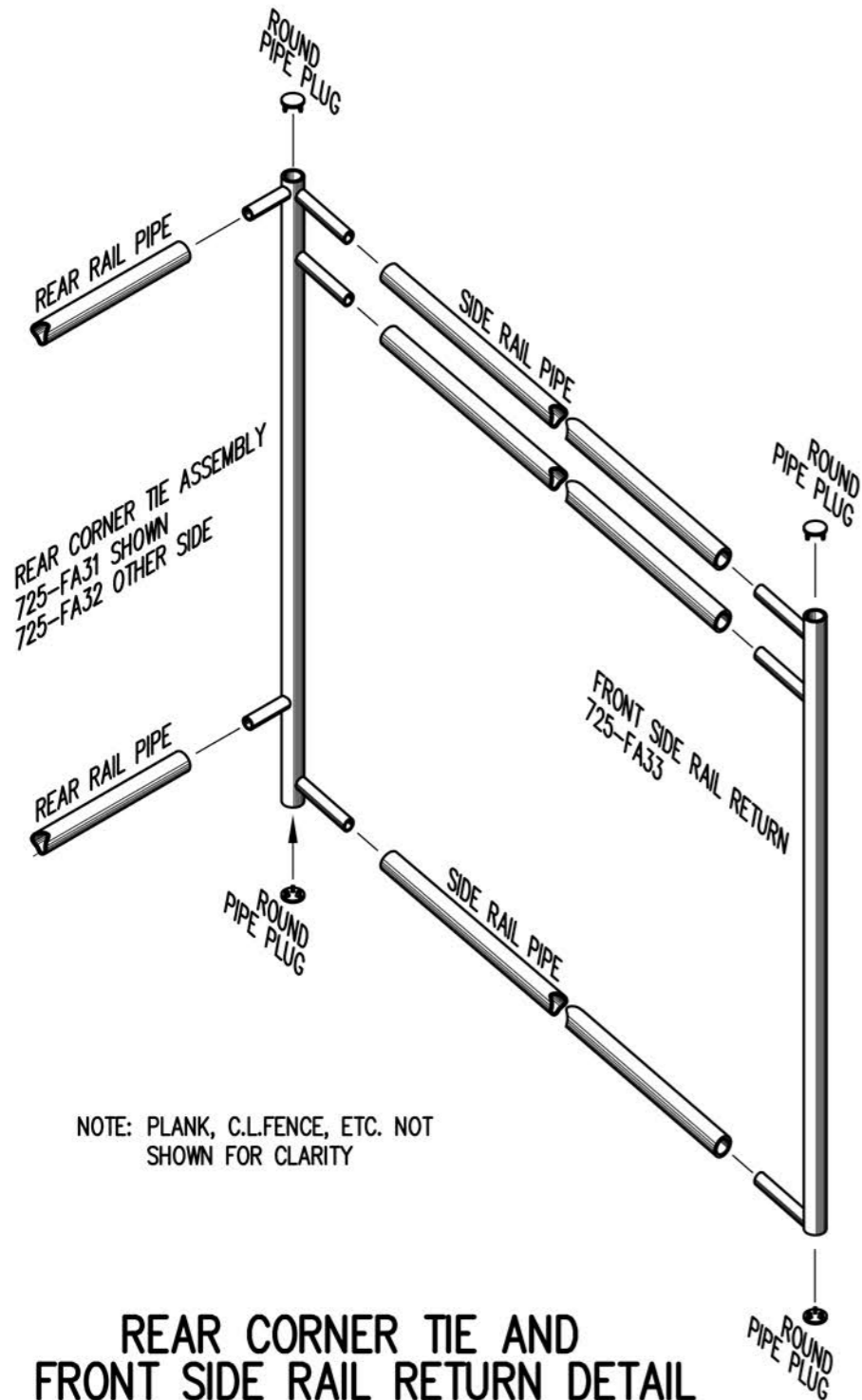

REAR CORNER TIE AND FRONT SIDE RAIL RETURN DETAIL

3/4" = 1'-0"

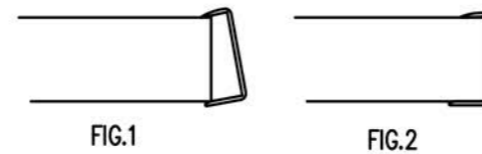

FIG.1

FIG.2

- 1) LOCATE THE CHANNEL END CAP AS SHOWN IN FIG. 1.
- 2) TAP END CAP INTO PLACE WITH RUBBER Mallet OR SOFT WOOD. FIG.2
- 3) DRILL 5/32" HOLES THROUGH THE BOTTOM FLANGE AND THE BOTTOM OUTSIDE PLANK FLANGES OF EACH PLANK. INSTALL 5/32" POP RIVETS.

END CAP DETAIL

N.T.S.

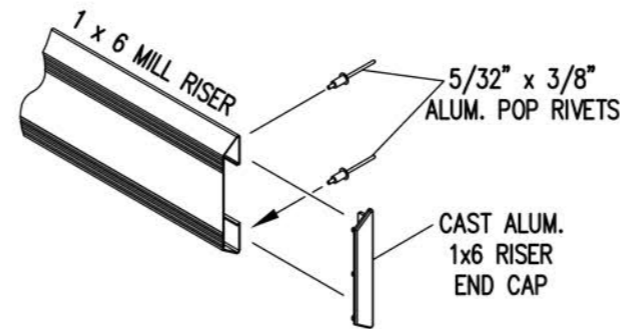

1 x 6 RISER END CAP

N.T.S.



TOP RAIL

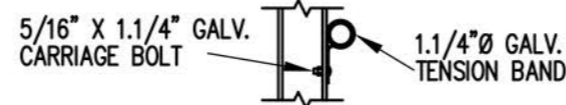

MID RAIL

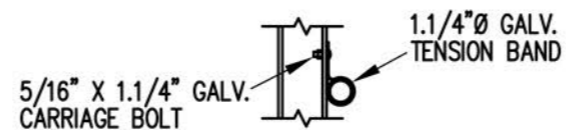

LOWER RAIL

3/4" = 1'-0"

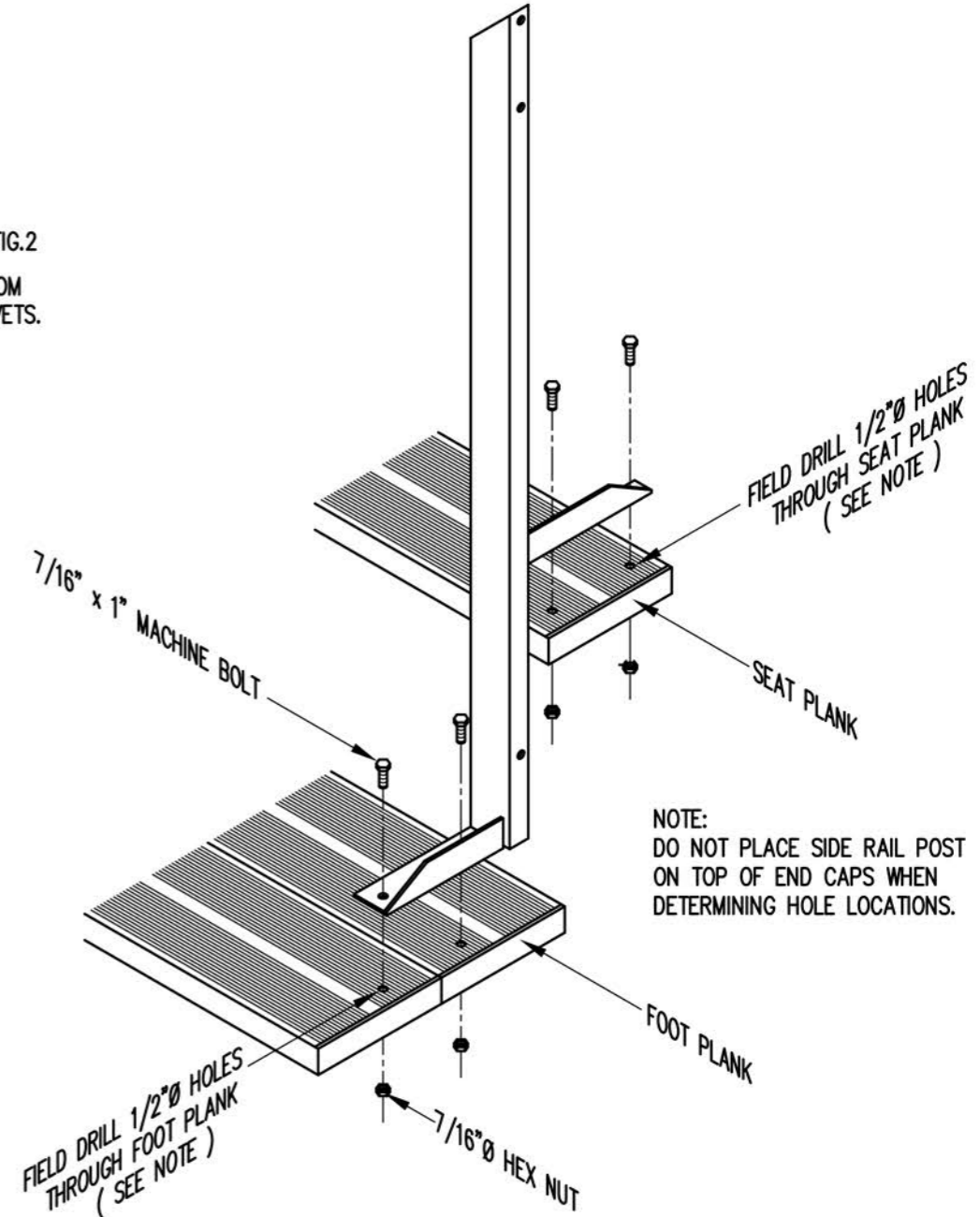

TYP. SIDE RAIL POST ATTACHMENT

1" = 1'-0"