



Post Finishes & Belt Options for 35 ft. Retractable Belt Barriers

Stanchions are crowd control devices we count on every day for organized foot traffic, even when we're not conscious of it. Whether you're catching a flight or picking up groceries, you've seen these simple posts in grocery stores, airports, shopping malls, museums, and schools. Almost anywhere there may be crowds, you'll find a stanchion guiding the way.

Retractable belt barrier stanchions are simply these stanchions which have built in retractable belts rather than hanging ropes. This kind of stanchion is especially common in retail line formation, as its belt conveniently stretches or retracts to accommodate custom lengths and line barriers.

Features

- High strength, tightly woven 2" wide belts: available in a variety of colors.
- Patent pending braking system: creates the safest post on the market.
- Universal belt clip: allows integration with many other manufacturers' units with slide-action lock..
- Built-in sign attachment: no costly adapters.
- Weather-Protection: posts can be modified for outdoor use.

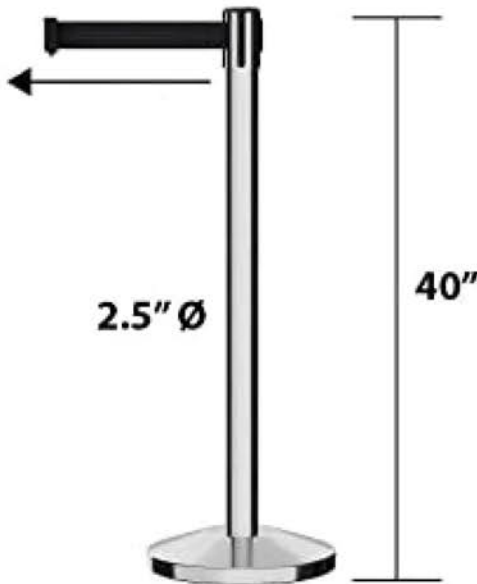

Unique locking mechanism provides the ability to lock retractable belts to make sure they stay in place in those key crowd control situations

4-way cassette features 3 receptacles which allow the unit to receive belts from up to 3 additional retractable belt stanchions

Post Finish Options



Powder Coated Black*



Powder Coated Yellow*



Powder Coated Red*



Powder Coated Orange*

*Can be weatherproofed for exterior use

Base Options

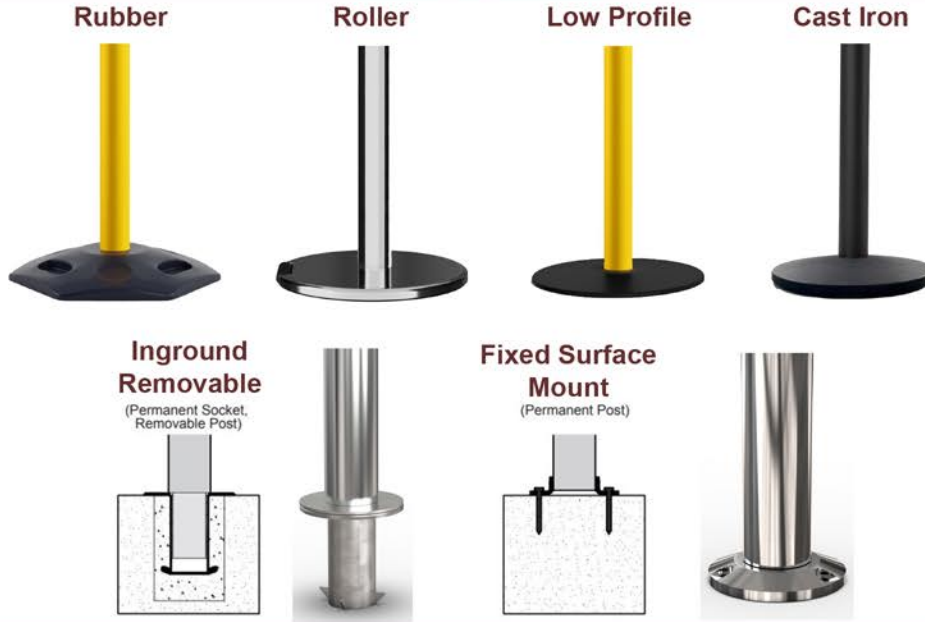

Belt Options

Standard Belts



Specialty Belts



*Due to printing limitations, colors shown may not represent actual product colors. Please call for samples if required

Custom Print Samples - Contact Our Team for Infomation

*Dye-Sub is not intended for prolonged exposure to UV



Crowd Control Warehouse LLC
(877) 885-1600 | (847) 991-9988 (fax)
sales@crowdcontrolwarehouse.com crowdcontrolwarehouse.com