



Post Finishes & Belt Options for Retractable Belt Barriers

Stanchions are crowd control devices we count on every day for organized foot traffic, even when we're not conscious of it. Whether you're catching a flight or picking up groceries, you've seen these simple posts in grocery stores, airports, shopping malls, museums, and schools. Almost anywhere there may be crowds, you'll find a stanchion guiding the way.

Retractable belt barrier stanchions are simply these stanchions which have built in retractable belts rather than hanging ropes. This kind of stanchion is especially common in retail line formation, as its belt conveniently stretches or retracts to accommodate custom lengths and line barriers.

Features

- High strength, tightly woven 2" wide belts: span from 10' to 65' available in a variety of colors.
- Patent pending braking system: creates the safest post on the market.
- Universal belt clip: allows integration with many other manufacturers' units with slide-action lock..
- Built-in sign attachment: no costly adapters.
- Weather-Protection: posts can be modified for outdoor use.

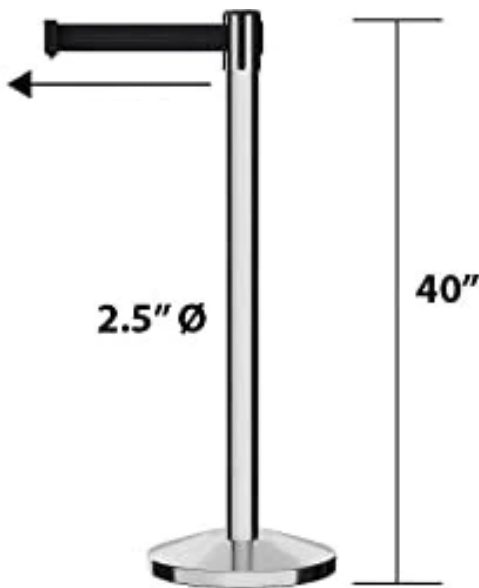

Unique locking mechanism provides the ability to lock retractable belts to make sure they stay in place in those key crowd control situations



4-way cassette features 3 receptacles which allow the unit to receive belts from up to 3 additional retractable belt stanchions

Post Finish Options



Powder Coated
Black*

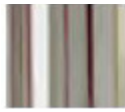

Polished
Stainless Steel



Satin
Stainless Steel



Polished
Brass



Satin
Brass



Powder Coated
Yellow*



Powder Coated
Red*



Powder Coated
Orange*

*Can be weatherproofed
for exterior use

Base Options

Standard Concrete & Steel



Water Fillable

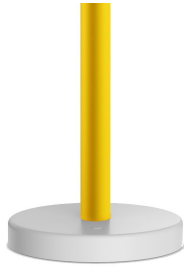

Rubber



Roller



Low Profile



Cast Iron



Inground Removable
(Permanent Socket, Removable Post)

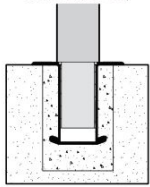

Fixed Surface Mount
(Permanent Post)

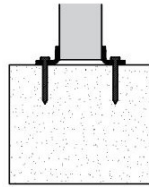

Magnetic
(Permanent Plate, Removable Post)

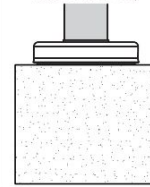

Belt Options

Standard Belts



Specialty Belts



*Due to printing limitations, colors shown may not represent actual product colors. Please call for samples if required

Custom Print Samples - Contact Our Team for Information

*Dye-Sub is not intended for prolonged exposure to UV

