

PRODUCT SPECIFICATIONS

- All metal fabricated parts are etched, phosphatized, preheated, primer powder coated, and final coat electrostatically powder coated.
- Colors include: Black, Evergreen, Dark Green White, Tan, Dark Brown, and Blue.
- Special order colors available.
- This product can ship either knocked down or assembled.

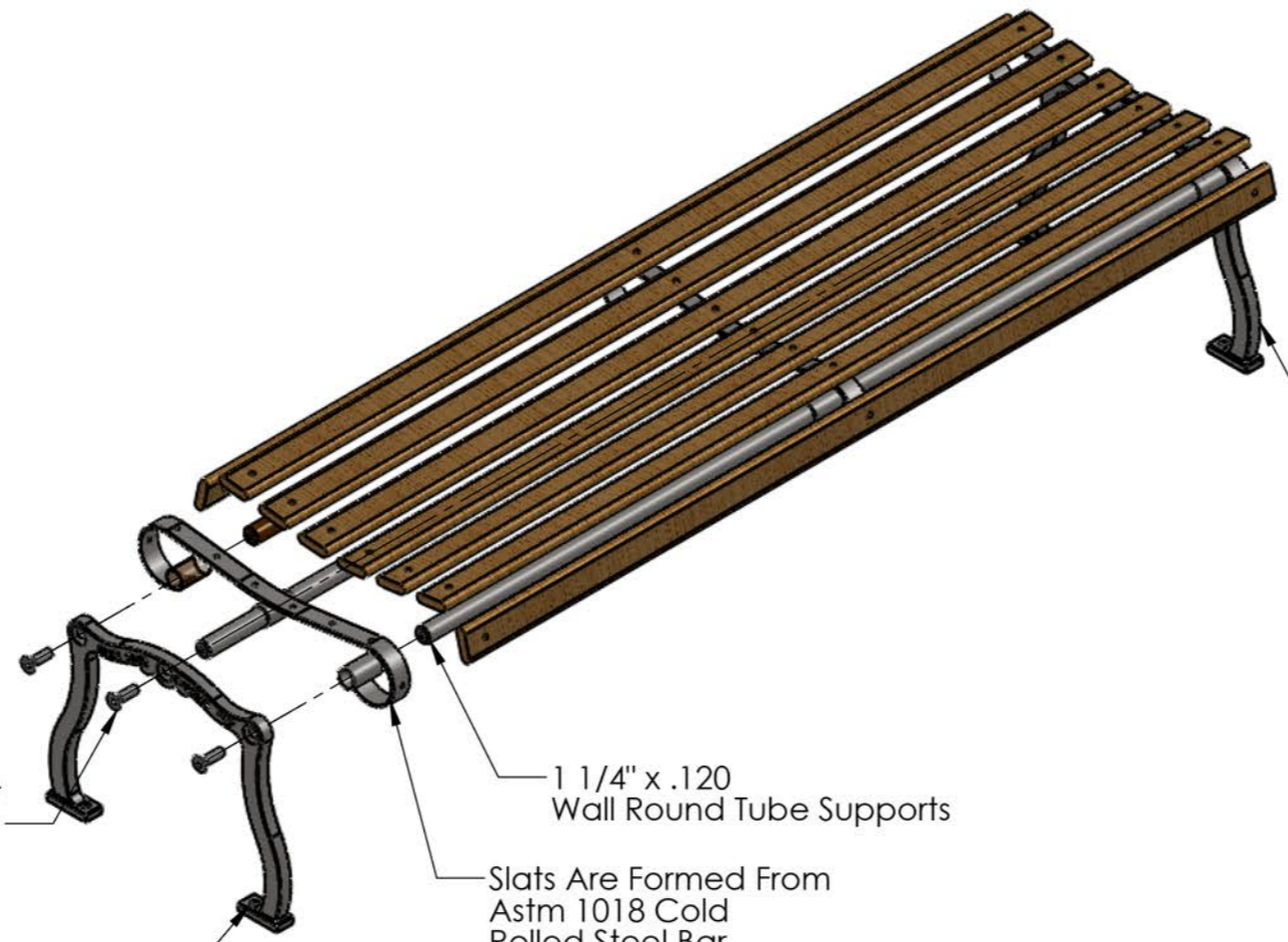
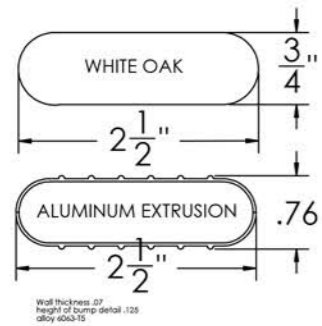

65-45-12 Ductile Iron Castings

Hardware:
(6) 1/2" x 2 1/2" Stainless Steel Flat Head Bolts

1 1/4" x .120 Wall Round Tube Supports

Slats Are Formed From Astm 1018 Cold Rolled Steel Bar. 1 1/2" x 3/16"

(6) Ø1/2" Mounting Holes

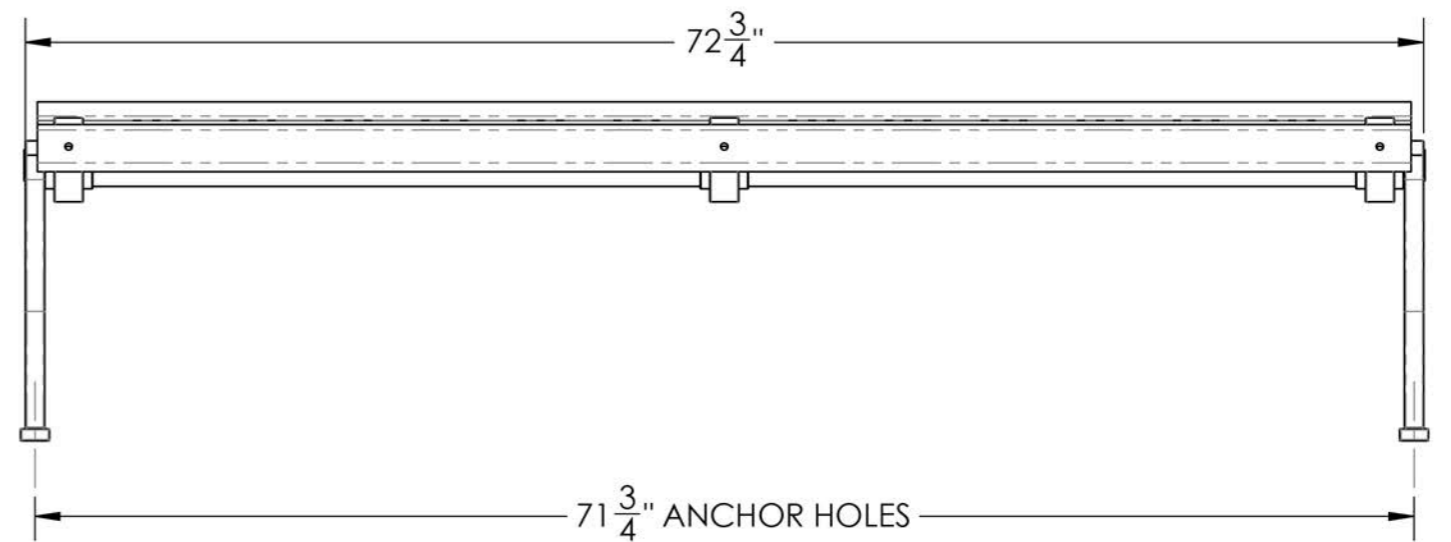
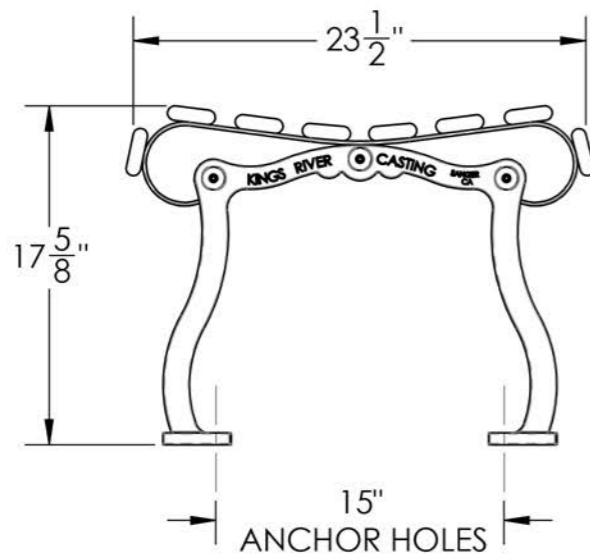

NOTE:

It is not recommended to locate anchor bolts until the bench is in place. Anchor bolts not included.