

**5-BIKE
DOUBLE SIDED**

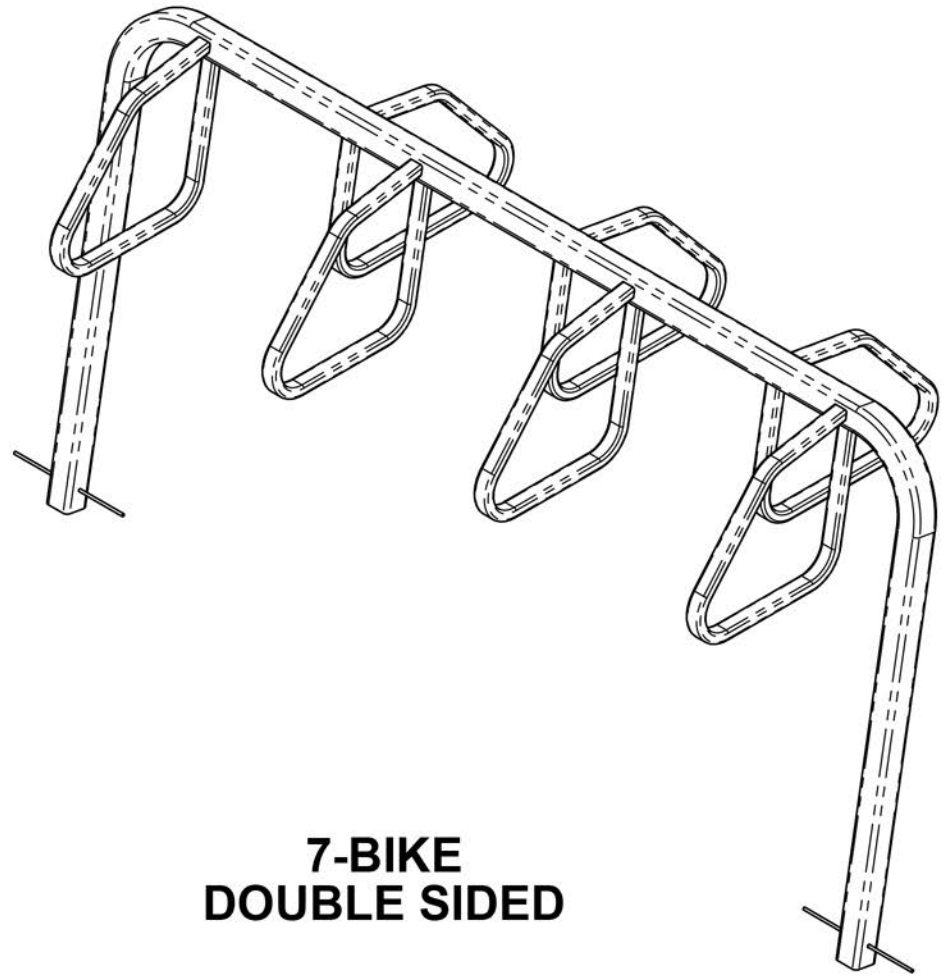

**7-BIKE
DOUBLE SIDED**

NOTES:

1. DO NOT SCALE DRAWING
2. INSTALLATION TO BE COMPLETED IN ACCORDANCE WITH MANUFACTURER'S SPECIFICATIONS.
3. FINISHING OPTIONS INCLUDE SUPER DURABLE POLYESTER POWDERCOAT AND HOT DIP GALVANIZING.
4. SEE WEBSITE OR CATALOG FOR POLYESTER POWDERCOAT COLOR OPTIONS.

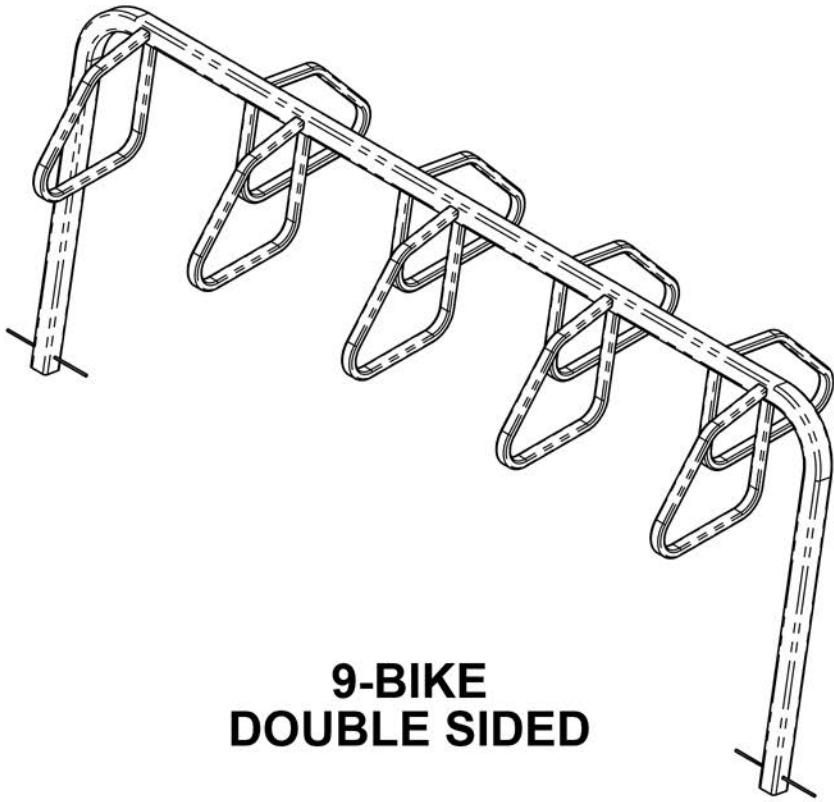

**9-BIKE
DOUBLE SIDED**

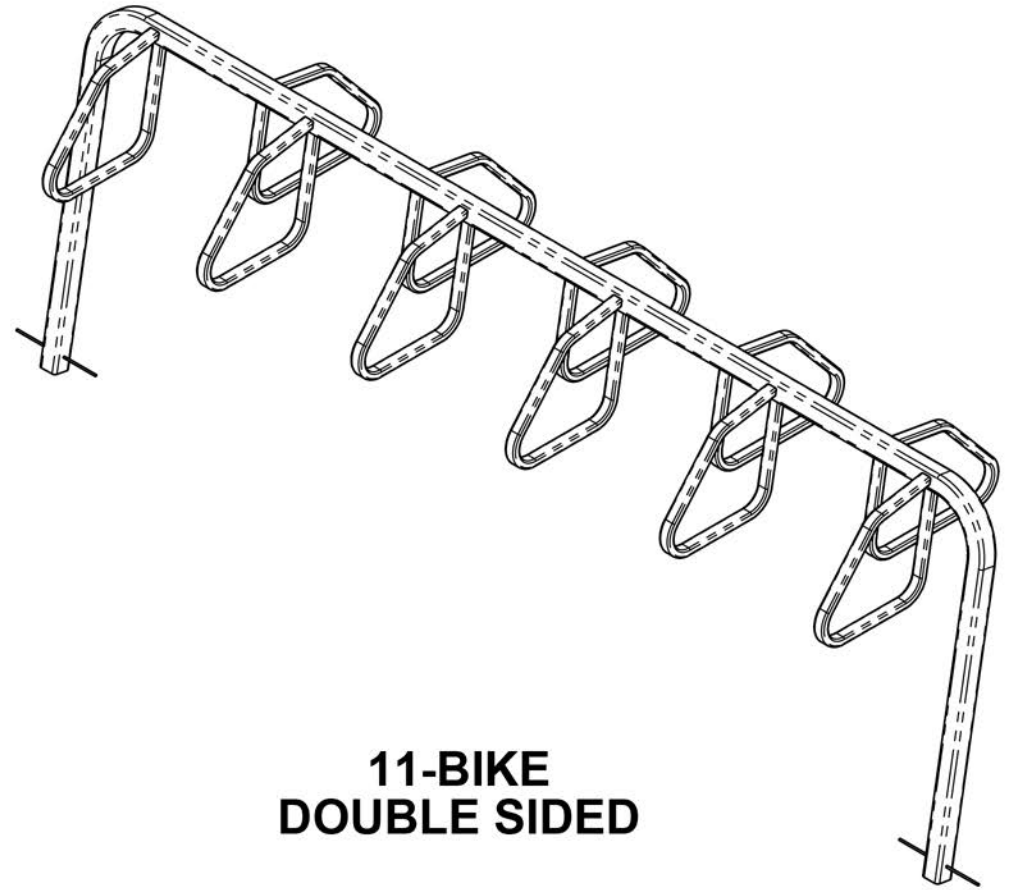

**11-BIKE
DOUBLE SIDED**

TABULATION

| BLACK P/N | COLOR P/N | GALVANIZED P/N | # OF BIKES | L1 | WEIGHT (LBS) |
|-----------|-----------|----------------|------------|-------|--------------|
| 2432 | 2432C | 2432G | 5 | 70.5 | 112.6 |
| 2435 | 2435C | 2435G | 7 | 95.5 | 139.6 |
| 2438 | 2438C | 2438G | 9 | 120.5 | 166.9 |
| 2441 | 2441C | 2441G | 11 | 145.5 | 194.1 |

