

X-BRACE DETAIL

N.T.S.

- 7/16" X 1" GALV. MACH. BOLT
- △ 7/16" X 1.1/2" GALV. MACH. BOLT

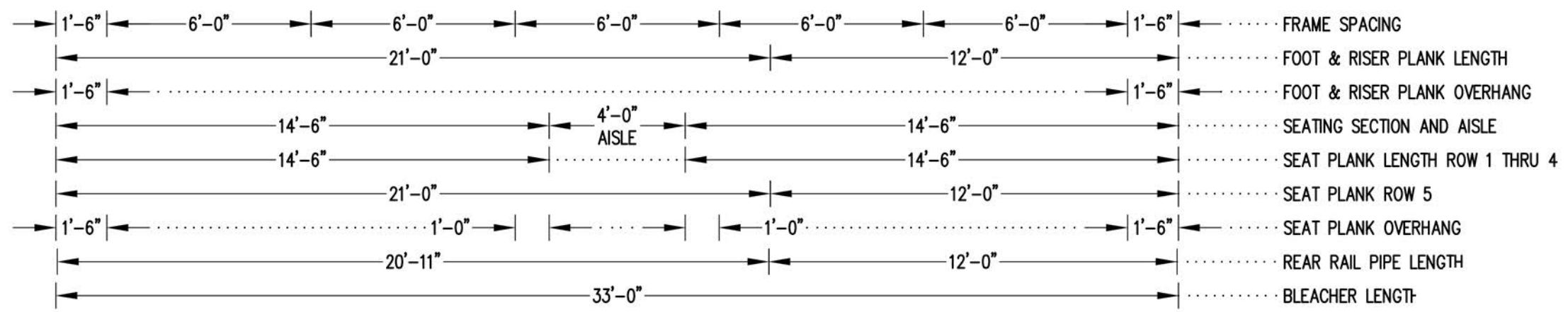
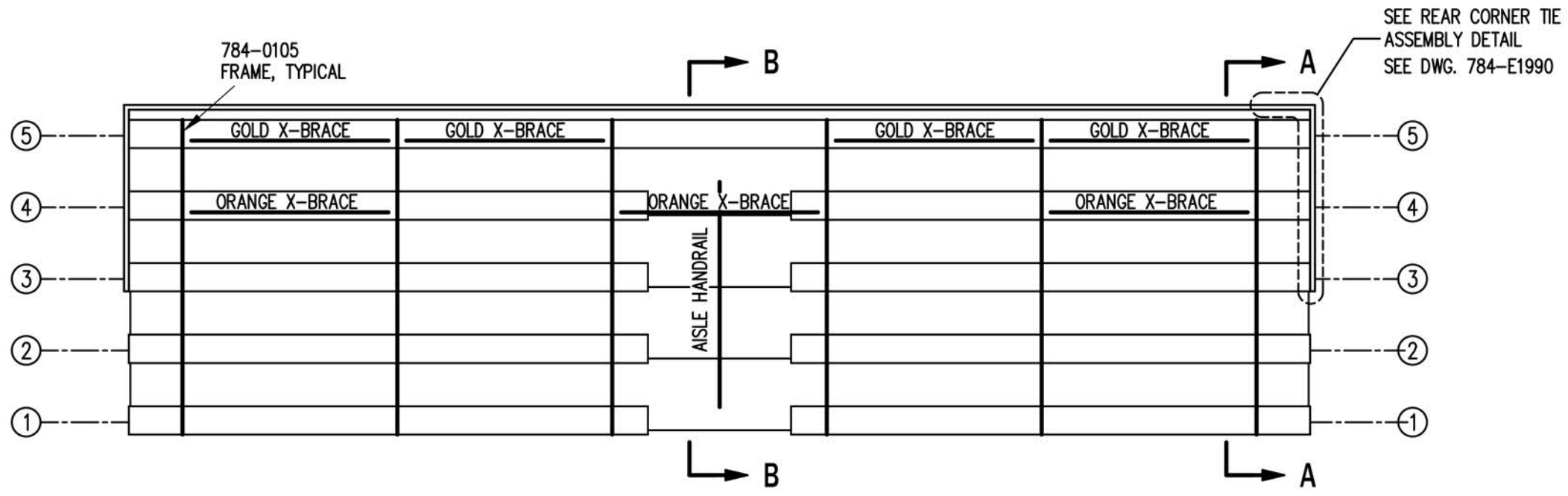

SEATING & FRAMING PLAN

1/4" = 1'-0"

94 NET SEATS @ 18" PER SEAT

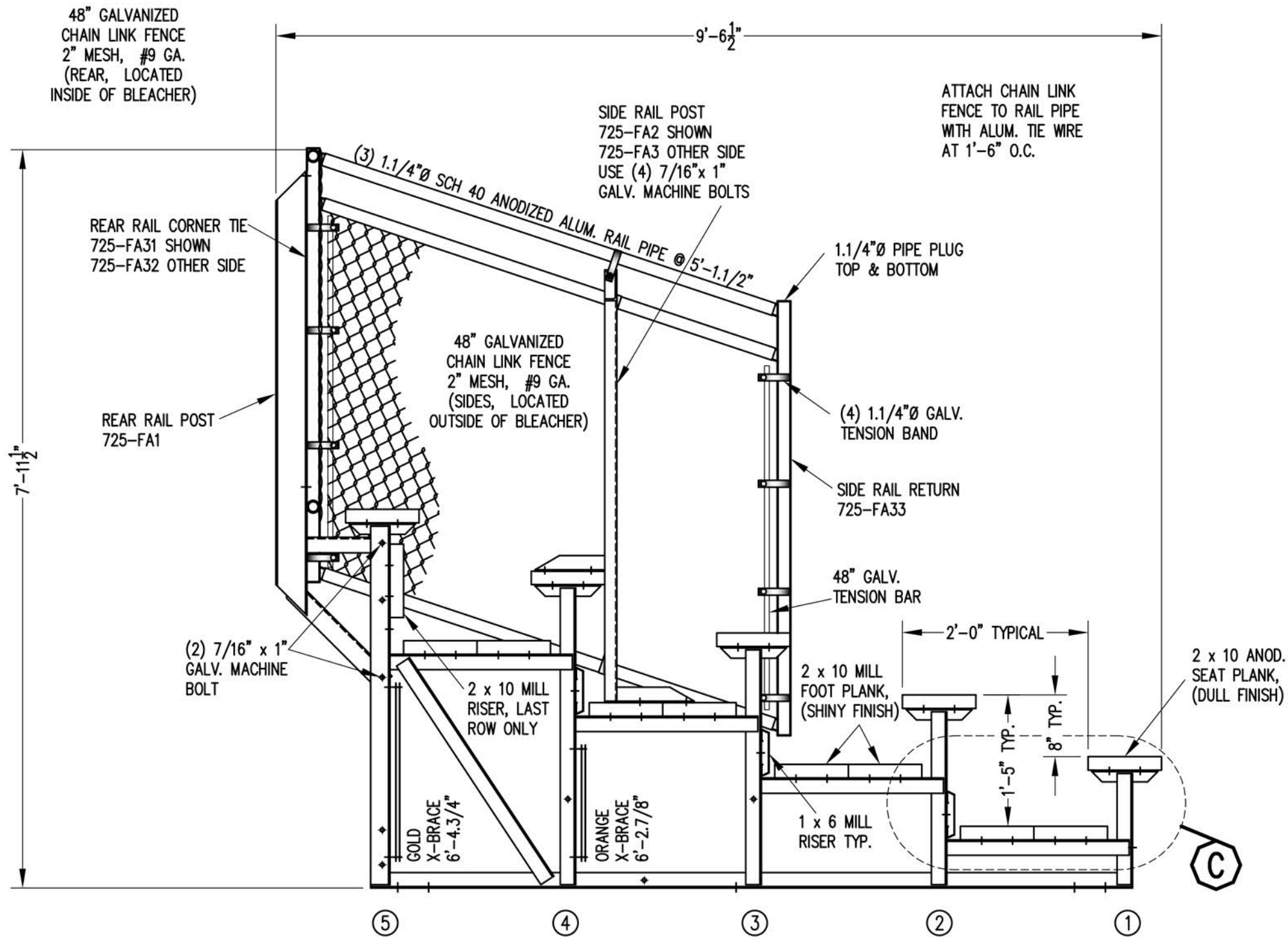

SECTION AA
3/4" = 1'-0"

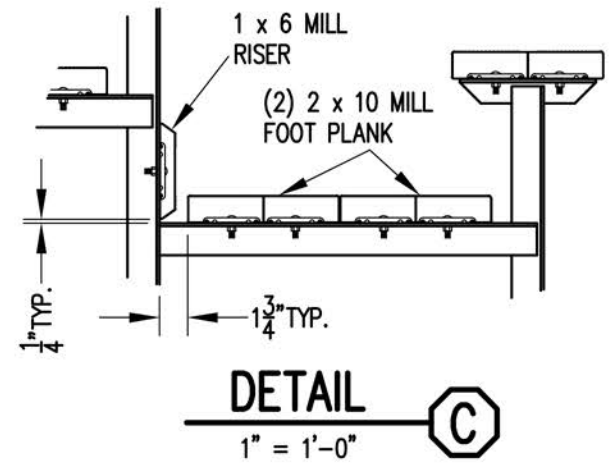

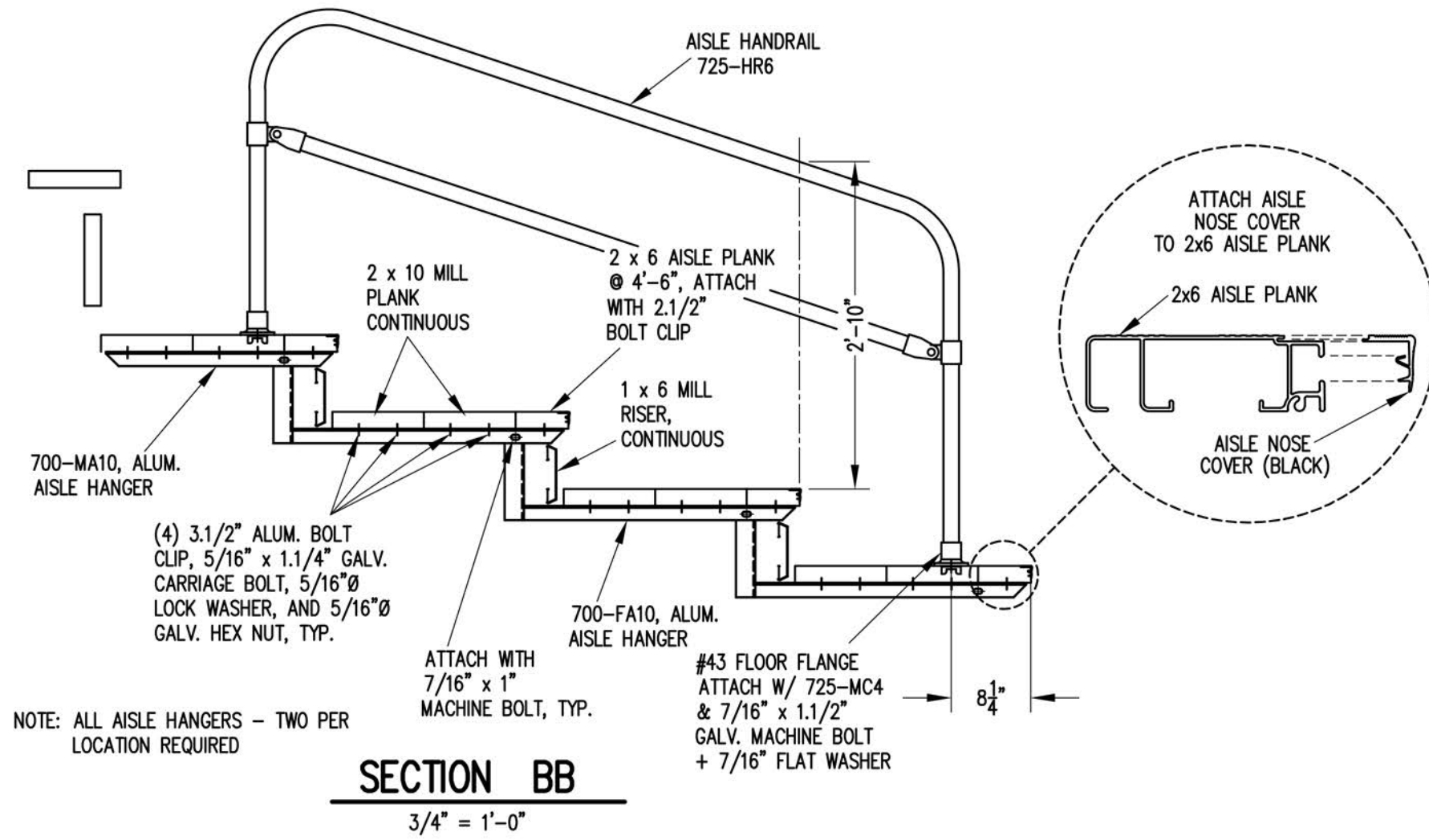

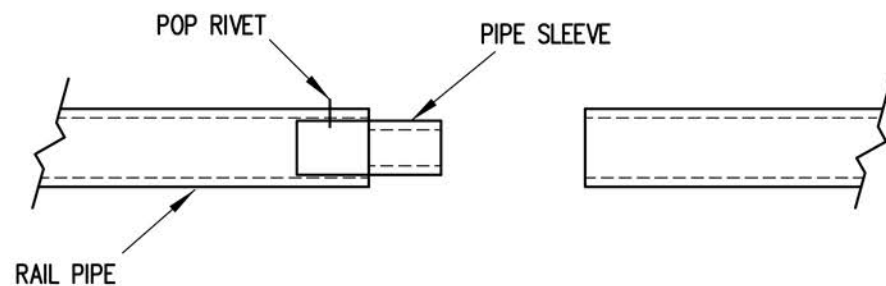

PIPE SLEEVE ASSEMBLY

1.1/2" = 1' 0"

- 1) INSERT PIPE SLEEVE APPROXIMATELY HALFWAY INTO THE RAIL PIPE. FASTEN PIPE SLEEVE WITH (1) ALUMINUM POP RIVET (5/32" X 5/8")
- 2) SLIDE THE END OF THE ADJOINING RAILPIPE OVER THE PIPE SLEEVE UNTIL THE TWO RAILS ARE FLUSH.

NOTE: PIPE SLEEVES SHOULD BE ATTACHED ON ONLY ONE END TO ALLOW FOR EXPANSION.

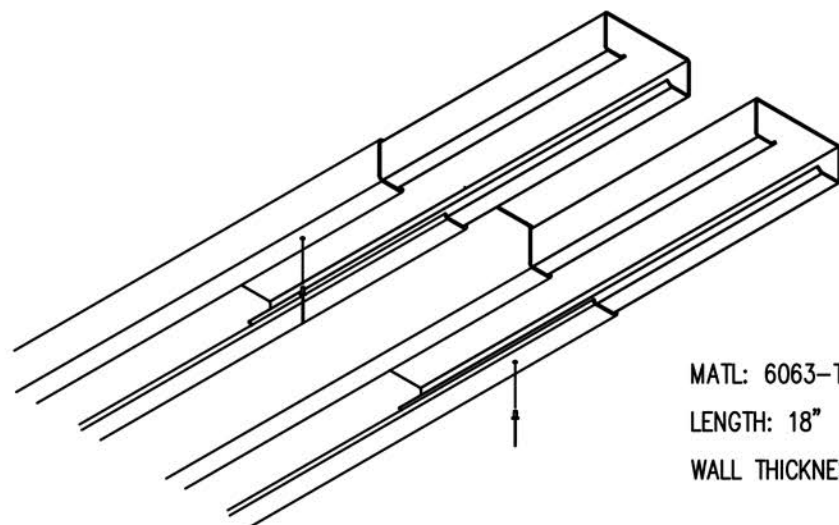

- 1) INSERT SLEEVES APPROXIMATELY HALFWAY INTO THE PLANK WITH THE ENDS STAGGERED ABOUT 1/2". FASTEN SLEEVE WITH (1) ALUMINUM POP RIVET.

- 2) SLIDE THE END OF THE ADJOINING PLANK OVER THE SLEEVES UNTIL THE TWO PLANKS ARE SNUG.

NOTE: SLEEVES SHOULD BE ATTACHED ON ONLY ONE END TO ALLOW FOR EXPANSION.

PLANK SPLICE SLEEVE ASSEMBLY

(TYP. @ ALL PLANK SPLICES)

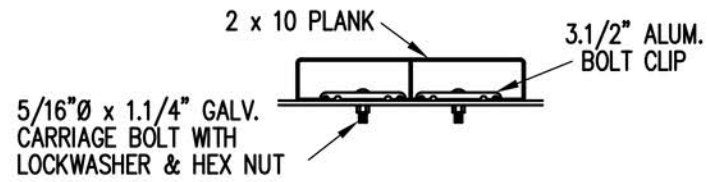

BOLT CLIP DETAIL

1.1/2" = 1'-0"



FIG.1

FIG.2

- 1) LOCATE THE CHANNEL END CAP AS SHOWN IN FIG. 1.
- 2) TAP END CAP INTO PLACE WITH RUBBER Mallet OR SOFT WOOD. FIG.2
- 3) DRILL 5/32" HOLES THROUGH THE BOTTOM FLANGE AND THE BOTTOM OUTSIDE PLANK FLANGES OF EACH PLANK. INSTALL 5/32" POP RIVETS.

END CAP DETAIL

N.T.S.

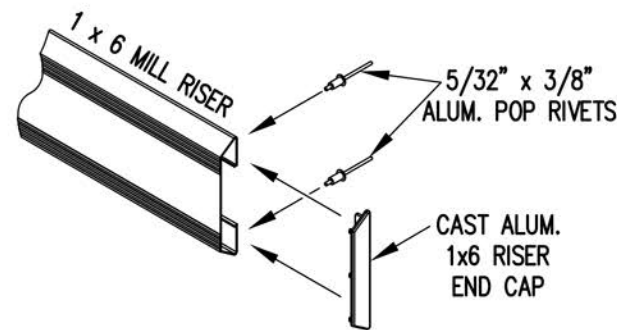

1 x 6 RISER END CAP

N.T.S.

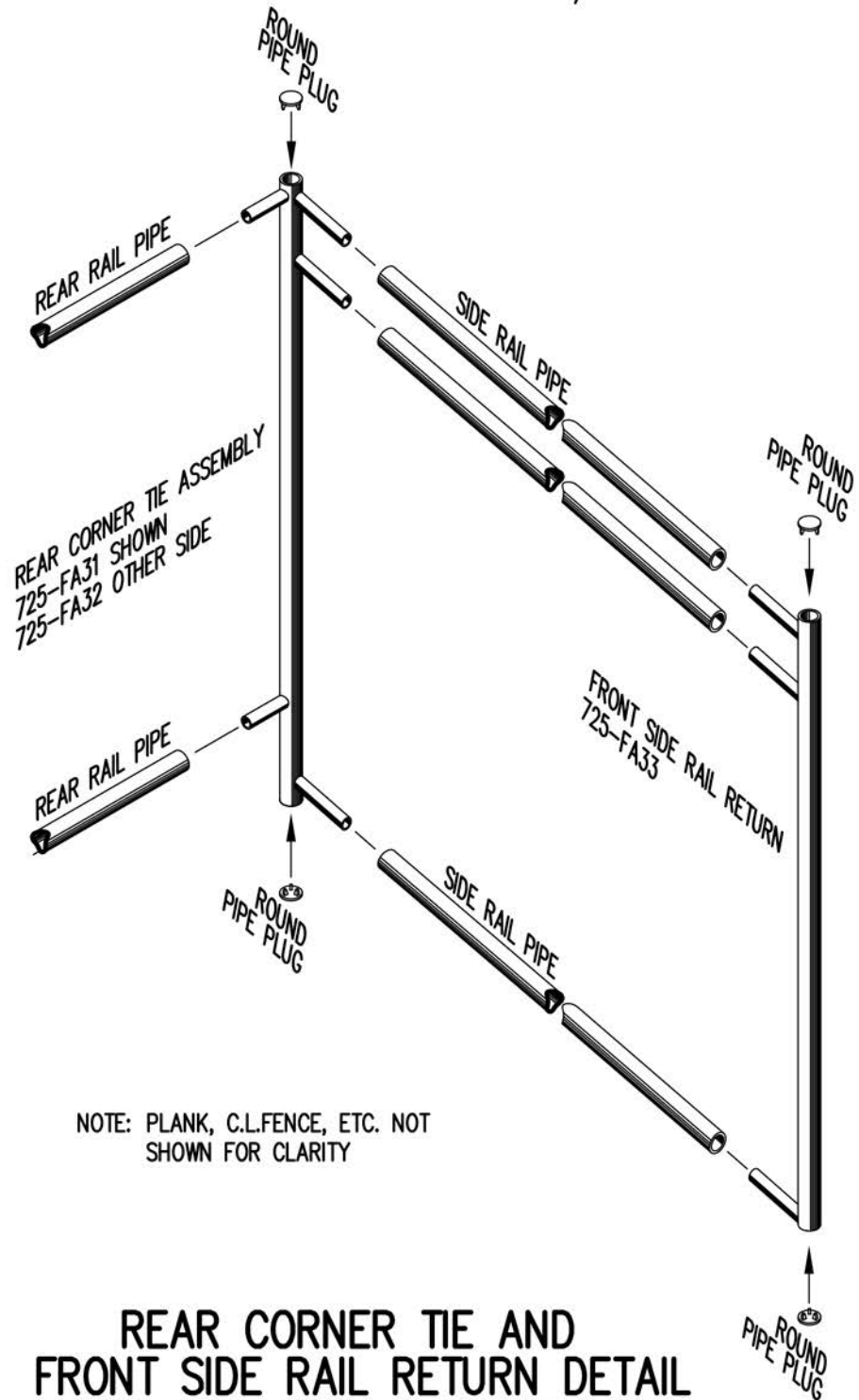

REAR CORNER TIE AND FRONT SIDE RAIL RETURN DETAIL

3/4" = 1'-0"

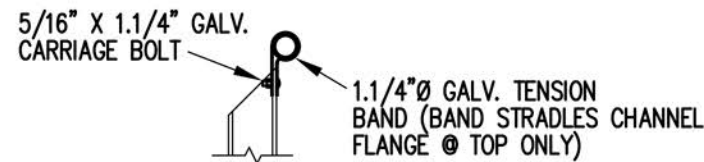

TOP RAIL



2ND RAIL

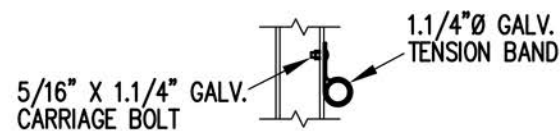

BOTTOM RAIL

RAIL PIPE ATTACHMENT

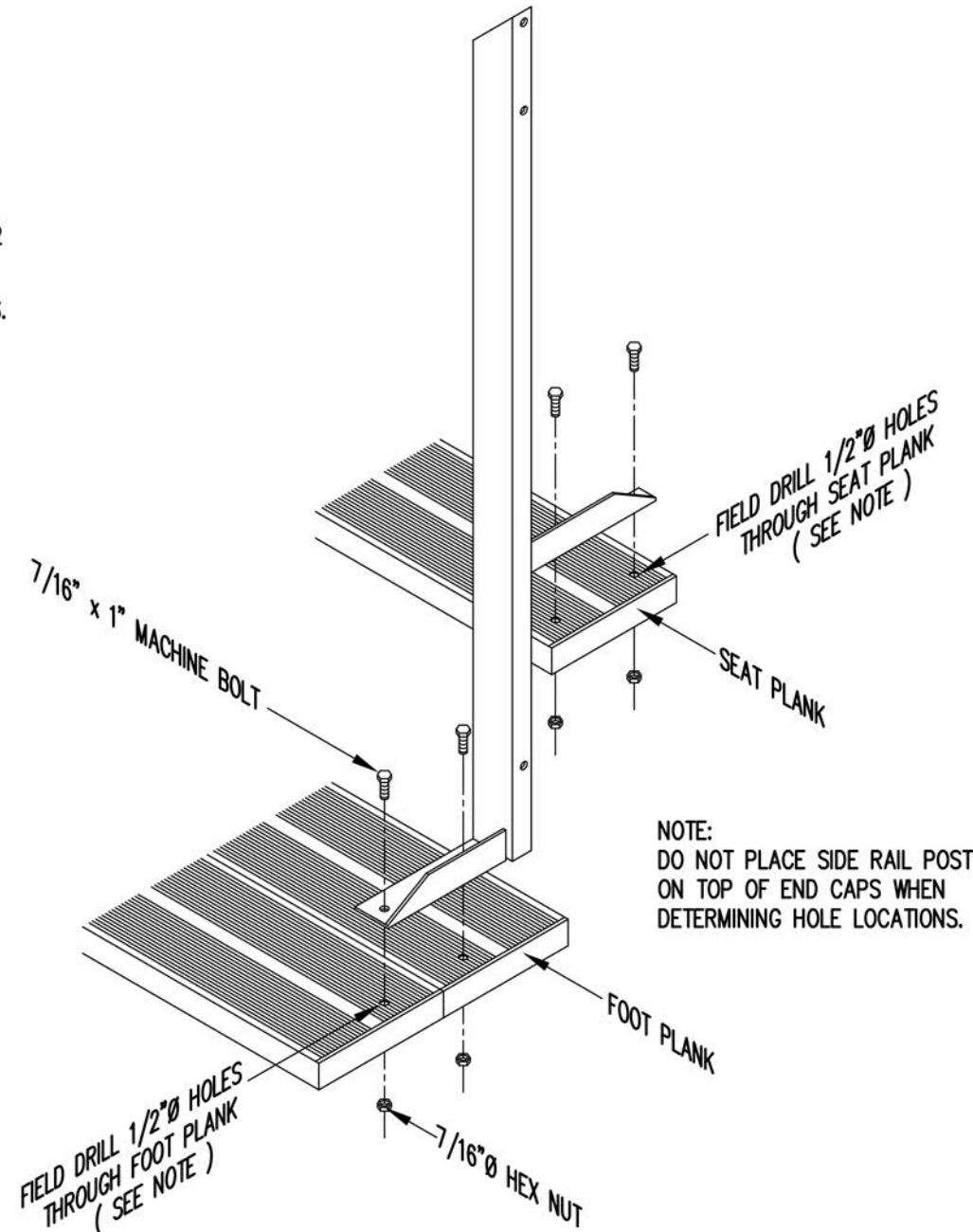

TYP. SIDE RAIL POST ATTACHMENT

1" = 1'-0"

NOTE: DO NOT PLACE SIDE RAIL POST ON TOP OF END CAPS WHEN DETERMINING HOLE LOCATIONS.