

Product Brochure

Dodge® ISN bearings



We provide motors, generators and mechanical power transmission products, services and expertise to save energy and improve customers' processes over the total lifecycle of our products, and beyond.



The mounted spherical roller bearing that lives up to its name

For more than 125 years, the Dodge® brand has been synonymous with the best the industry has to offer. Bearing users throughout the world recognize that, with Dodge, they have access to the best selection of the highest quality mounted bearings in the industry.

These assurances are now more evident than ever in our complete family of Dodge ISN spherical roller bearings—the only high-capacity double-row spherical roller bearings with an effective easy-on, easy-off adapter mounting and removal system. Not only does this patented system provide a concentric grip for superior holding on the shaft, it ensures that the bearing can be mounted and dismounted in less than fifteen minutes.

Combine these features with the ISN bearings' superior sealing systems and compact one-piece, industry-standard dimensioned housings, and you have a family of mounted roller bearings which lives up to its name.



The original Dodge® ISN mounted bearings

Patented sealing options

An ineffective seal can allow contaminants to enter a bearing, which can cause failure. However, with ISN bearing inserts, there are two exclusive seals for maximum sealing protection.

Our proven Trident seals are extremely effective for dirty environments, low-to-medium speeds, and normal ambient conditions. Made of nitrile material, this triple-lip rubbing seal has a low coefficient of friction, and its seal land maintains full seal contact even when misaligned.

For higher speeds and harsher ambient conditions, ISN inserts offer labyrinth seals with corrosion-resistant flingers and steel clearance seal carriers.

ISN spherical plummer blocks

- Patented ISN "Push/Pull" adapter mounting system
- Eliminates need for feeler gauges
- Easy removal
- Expansion & non-expansion, field convertible
- Triple lip contact seals for wet or dirty applications
- Labyrinth non-contact seals for high speed & high temperature applications

Time saving removal and replacement design

- 1) Steel cage provides precision roller guidance
- 2) Outer ring riding two-piece guide ring minimizes heat generation
- 3) Tapered seal land maintains full contact when misaligned
- 4) Patented nitrile triple lip seal resists heat & chemical breakdown
- 5) Ease in mounting & dismounting with patented adapter system
- 6) Adapter sleeve improves concentricity and reduces vibration

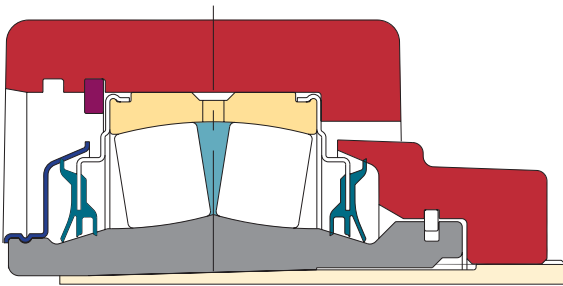

Trident® seals

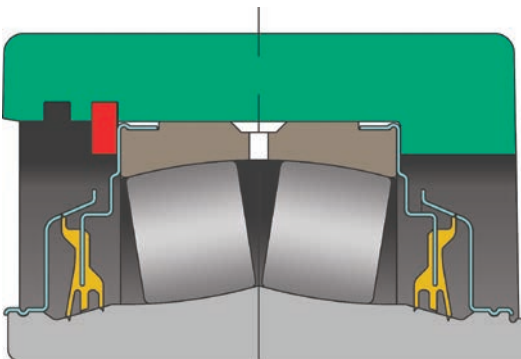

Labyrinth seals

Patented adapter system can be installed or removed in 15 minutes

- Clockwise rotation of the locknut pushes the tapered adapter sleeve between the shaft and bearing inner ring, allowing quick metal to metal contact during initial installation.
- Locknut is then further rotated for a pre-determined number of turns, properly reducing bearing clearance. No feeler gauges are used.
- Lock plate keeps locknut tight for dependable shaft attachment
- Integral locknut-inner ring design allows efficient removal of the sleeve from the bearing assembly via counter clockwise rotation of the locknut

IP Housing Options

- P2B-ISN: 30-140 mm (1 1/8"-5")
- P2B-IP: 35-100 mm (1 1/8"-4")
- F4B-IP: 35-100 mm (1 7/16"-3 15/16")
- WSTU-IP: 35-100 mm (1 1/8"-4")
- P2B-ISAF: 35-90 mm (1 7/16"- 3 7/16")
- P4B-ISAF: 65-170 mm (2 7/16"-7")
- P4B-IP: 65-125 mm (2 3/8"-5")
- FC-IP: 35-125 mm (1 1/8"-5")
- IP Insert: 35-170 mm (1 1/8"-7")



ISN and IP configuration options: ISN series

Interchangeable with competitive SN products

- Two-bolt plummer blocks: 30-140 mm (1 1/8"-5")

ISAF Series

Interchangeable with Dodge USAF and many competitive SAF products

- Two-bolt plummer blocks: 35-90 mm (1-7/16" up to 3-7/16")
- Four-bolt plummer blocks: 65-170 mm (2-7/16" up to 7")

IP Series

Interchangeable with Dodge

S-2000 unitized housings and many competitive products.

- Two-bolt plummer blocks: 35-100 mm (1-1/8" to 4")
- Four-bolt plummer blocks: 65-125 mm (2-3/8" up to 5")
- Four-bolt flanges: 35-100 mm (1-1/8" up to 4")
- Flange bearings piloted: 35-125 mm (1-1/8" to 5")
- Wide slot take-up: 35-100 mm (1-1/8" to 4")
- Inserts: 35-170 mm (1-1/8" to 7")

IP-E Series

Our IP-E bearing is now available with Type E mounting dimensions

- Two-bolt plummer blocks: 35-90 mm (1-3/8" up to 3 1/2")
- Four-bolt plummer blocks: 65-170 mm (2-1/4" up to 7")
- Four-bolt flanges: 35-115 mm (1-3/8" up to 4-1/2")
- Piloted flanges: 35-125 mm (1-3/8" up to 5")
- Wide slot take-ups: 35-100 mm (1-1/8" up to 4")

Dodge® ISN benefits

Dodge ISN bearings vs. standard SN products

Dodge ISN series	Standard SN products
One package—shaft ready	Trois paquets ou plus—assemblage par l'utilisateur
Bearing matched to shaft	Bearing oversized to accommodate adapter
Simple clearance setting—no special tools or feeler gauges	Requires feeler gauges
100% seal constant pressure	Seals in the housing—loses effectiveness when misaligned
Greased at the factory	User packs the grease and cleans the mess
Grease retained near the rollers with the seal	Grease migrates out to the housing cavity away from the rollers
Reduced grease consumption	Large cavity to fill with grease
Factory sealed	Subject to on site contamination
Easy, intuitive removal method	Difficult removal



ISN: Dimensional interchange with other SN plummer blocks

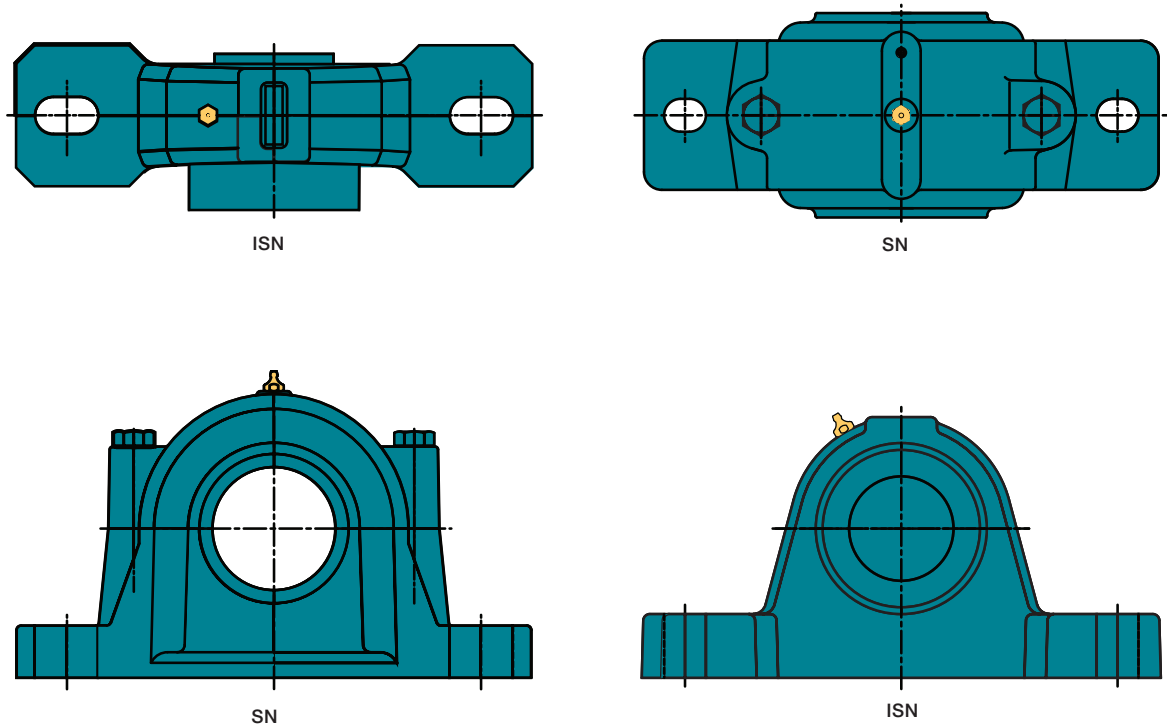

Only the best bearings come from the best plant

Our Dodge Type E, S-2000, S-2000-E, ISN and IP-E bearings are the best. Manufactured at our Marion, NC, plant—one of IndustryWeek's Top 10 Best Plants for 2004—they represent the best in roller bearing technology and innovation.

When you want the best bearings, look to Dodge and our plant in Marion, NC. Together, they are your best source for performance-proven solutions.

Bearing users throughout the world recognize that, with Dodge, they have access to the best selection of the highest quality of mounted bearings in the industry.

Contact:

www.abb.com/mechanicalpowertransmission

Note:

We reserve the right to make technical changes or modify the contents of this document without prior notice. With regard to purchase orders, the agreed particulars shall prevail. ABB Ltd does not accept any responsibility whatsoever for potential errors or possible lack of information in this document.

We reserve the rights in this document and in the subject matter and illustrations contained therein. Any reproduction, disclosure to third parties or utilization of its contents - in whole or in parts - is forbidden without prior written consent of ABB Ltd.

Copyright© 2012 ABB
All rights reserved

MPT products ROW EN 2012-11 Printed in USA 2000 IBR3010