

6-Day Forecast WI-FI Weather Station With 7-in-1 Professional Sensor Model: YC9475 User Manual



* POLE IS FOR ILLUSTRATION PURPOSE. IT'S NOT INCLUDED.

TABLE OF CONTENTS

1.	INTRODUCTION	4
1.1	QUICK START GUIDE	5
2.	PRE INSTALLATION	5
2.1	CHECKOUT	5
2.2	SITE SELECTION	5
3.	GETTING STARTED	6
3.1	WIRELESS 7-IN-1 SENSOR	6
3.1.1	INSTALL WIND VANE	6
3.1.2	INSTALL RAIN GAUGE FUNNEL	7
3.1.3	INSTALL BATTERIES	7
3.1.4	INSTALL MOUNTING POLE	7
3.1.5	DIRECTION ALIGNMENT	8
3.1.6	POINTING THE WIRELESS 7-IN-1 SENSOR TO SOUTH	8
3.2	SYNCHRONIZING ADDITIONAL SENSOR(S) (OPTIONAL)	9
3.3	RECOMMENDATION FOR BEST WIRELESS COMMUNICATION	10
3.4	SETUP THE CONSOLE	10
3.4.1	POWER UP THE DISPLAY CONSOLE	10
3.4.2	SETUP DISPLAY CONSOLE	11
3.4.3	SYNCHRONIZING WIRELESS 7-IN-1 SENSOR	11
3.4.4	DATA CLEARING	11
4.	DISPLAY CONSOLE FUNCTIONS AND OPERATION	12
4.1	SCREEN DISPLAY	12
4.2	DISPLAY CONSOLE KEYS	12
4.3	CONSOLE FEATURES	14
4.3.1	MULTI-DAY WEATHER FORECAST FOR TODAY & NEXT 5 DAY	14
4.3.2	HIGH-LOW TEMPERATURE FORECAST FOR TODAY & NEXT 5 DAYS	14
4.3.3	AVERAGE TEMPERATURE FORECAST WITH CHANCE OF RAIN FOR TODAY & NEXT 5 DAYS	15
4.3.4	OUTDOOR TEMPERATURE, HUMIDITY & TEMPERATURE INDEX	15
4.3.5	INDOOR / CHANNELS TEMPERATURE & HUMIDITY	16
4.3.6	MULTI-CHANNEL AND SCROLL MODE FOR OPTIONAL SENSORS	17
4.3.7	WATER LEAK (OPTIONAL LEAK SENSOR)	17
4.3.8	WIND	18
4.3.9	BAROMETRIC PRESSURE	20
4.3.10	RAIN	20
4.3.11	LIGHT INTENSITY, UV INDEX & SUNBURN TIME	20
4.3.12	AIR QUALITY	21
4.3.13	SKY CONDITION	22
4.3.14	MAXIMUM / MINIMUM RECORDS	22
4.3.15	MOON PHASE	23
4.3.16	SUNRISE / SUNSET & MOON RISE / MOON SET TIME	23
4.3.17	WIRELESS SENSOR SIGNAL RECEIVING	23
4.3.18	TIME SYNCHRONIZE STATUS	23
4.3.19	WI-FI CONNECTION STATUS	24
4.4	OTHER SETTING	24
4.4.1	TIME, DATE AND GENERAL SETTING	24
4.4.2	SETTING ALARM TIME	24
4.4.3	UNIT SETTING	25
4.4.4	BACK LIGHT	25
5.	CREATE PWL ACCOUNT & SETUP WI-FI CONNECTION OF CONSOLE	26
5.1	CREATE PWL ACCOUNT AND ADD NEW DEVICE IN PWL	26
6.	CONNECT CONSOLE TO WI-FI	28
6.1	CONSOLE IN ACCESS POINT MODE	28
6.2	CONNECT TO THE CONSOLE	28
6.3	SETUP THE WEATHER SERVER CONNECTION	29
6.4	ADVANCE SETTING IN WEB INTERFACE	30
6.4.1	CALIBRATION	31

7. PROWEATHERLIVE (PWL) LIVE DATA & OPERATION	31
7.1 VIEW LIVE DATA	31
7.2 UPLOAD TO OTHER WEATHER SERVERS	31
8. MAINTENANCE	32
8.1 FIRMWARE UPDATE	32
8.1.1 FIRMWARE UPDATE STEP	32
8.2 BATTERY REPLACEMENT	32
8.2.1 RE-PAIRING THE SENSOR(S) MANUALLY	33
8.3 RESET AND FACTORY RESET	33
8.4 WIRELESS 7-IN-1 SENSOR ARRAY MAINTENANCE	33
9. TROUBLESHOOT	33
10. SPECIFICATIONS	34
10.1 CONSOLE	34
10.2 WIRELESS 7-IN-1 SENSOR	36

ABOUT THIS USER'S MANUAL



This symbol represents a warning. To ensure safe use, always adhere to the instructions described in this documentation.



This symbol is followed by a user's tip.



PRECAUTIONS



- Keeping and reading the "User manual" is highly recommended. The manufacturer and supplier cannot accept any responsibility for any incorrect readings, export data lost and any consequences that occur should an inaccurate reading take place.
- Images shown in this manual may differ from the actual display.
- The contents of this manual may not be reproduced without the permission of the manufacturer.
- Technical specifications and user manual contents for this product are subject to change without notice.
- This product is not to be used for medical purposes or for public information
- Do not subject the unit to excessive force, shock, dust, temperature or humidity.
- Do not cover the ventilation holes with any items such as newspapers, curtains etc.
- Do not immerse the unit in water. If you spill liquid over it, dry it immediately with a soft, lint-free cloth.
- Do not clean the unit with abrasive or corrosive materials.
- Do not tamper with the unit's internal components. This invalidates the warranty.
- Placement of this product on certain types of wood may result in damage to its finishing for which manufacturer will not be responsible. Consult the furniture manufacturer's care instructions for information.
- Only use attachments / accessories specified by the manufacturer.
- This product is not a toy. Keep out of the reach of children.
- The console is intended to be used only indoors.
- Place the console at least 20cm from nearby persons.
- Console working temperature: -5°C ~ 50°C

WARNING

- Do not ingest the battery. Chemical Burn Hazard.
- This product contains a coin/button cell battery. If the coin/button cell battery is swallowed, it can cause severe internal burns in just 2 hours and can lead to death.
- Keep new and used batteries apart. If battery door does not close securely, stop using the product and keep it away from children.
- If you think batteries might have been swallowed or placed inside any part of the body, seek immediate medical attention.
- An appliance is only suitable for mounting at height ≤ 2m. (Equipment mass ≤ 1kg)
- This product is intended for use only with the adaptor provided:
 - Manufacturer: Hua Xu Electronics Factory
 - Model: HX075-0501000-AB
- This device is only suitable for mounting at height < 2m.
- When disposing of this product, ensure it is collected separately for special treatment.
- The AC/DC adaptor is used as disconnect device.

- The AC/DC adaptor of apparatus should not be obstructed OR should be easily accessed during intended used.
- To be completely disconnect the power input, the AC/DC adaptor of apparatus shall be disconnected from the mains.

CAUTION

- Danger of explosion if battery is incorrectly replaced. Replace only with the same or equivalent type.
- Battery cannot be subjected to high or low extreme temperatures, low air pressure at high altitude during use, storage or transportation.
- Replacement of a battery with an incorrect type can result in an explosion or the leakage of flammable liquid or gas.
- Disposal of a battery into fire or a hot oven, or mechanically crushing or cutting of a battery, can result in an explosion.
- Leaving a battery in an extremely high temperature surrounding environment can result in an explosion or the leakage of flammable liquid or gas.
- A battery subjected to extremely low air pressure may result in an explosion or the leakage of flammable liquid or gas.

1. INTRODUCTION

Thank you for your purchase of 6-Day Forecast WI-FI Weather Station. This system gathers many advance features for weather observer, such as ProWeatherLive (PWL) cloud service which provide online weather forecast and condition of your area onto your console while at the same time receiving your personal weather data upload to be viewed on PWL website or PWL App anytime. The 7-in-1 professional wireless sensor-array integrates temperature, humidity, wind, rain, UV and light sensors together, to continually monitoring your local weather conditions at all time and transmit these data to your console through wireless radio frequency technology. This system also support up to 7 thermo-hygro sensor(s) and other advance optional sensor(s) such as PM2.5/10, lighting and water leak sensors that also allow you to monitor all your environment condition in one system, one app.

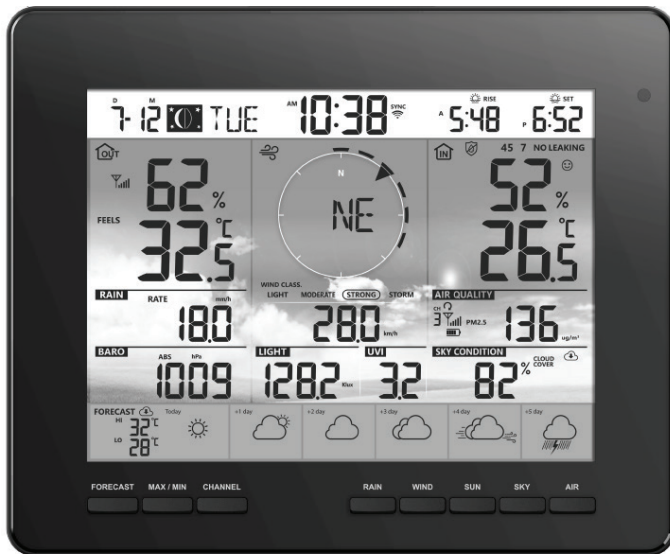

1.1 QUICK START GUIDE

The following Quick Start Guide provides the necessary steps to install and operate the weather station, and upload to the Internet, along with references to the pertinent sections.

Step	Description	Section
1	Power up the 7-in-1 sensor array	3.1.3
2	Power up the display console and pair with sensor array	3.4
3	Manually set date and time (This part is unnecessary if the weather station is connected to PWL later)	4.4.1
4	Reset the rain to zero	4.3.10.2
5	Create account and register weather station at PWL	5
6	Connect weather station to WiFi	6.1, 6.2, 6.3

2. PRE INSTALLATION

2.1 CHECKOUT

Before permanently install your weather station, we recommend the user to operate the weather station at a location which is easy to access to. This will allow you to get familiar with the weather station functions and calibration procedures, to ensure proper operation before installing it permanently.

2.2 SITE SELECTION

Before installing the sensor array, please consider the followings;

1. Rain gauge must be clean every few months
2. Batteries must be changed every 2 to 2.5 years
3. Avoid radiant heat reflected from any adjacent buildings and structures. Ideally, the sensor array should be installed at 1.5m (5') from any building, structure, ground or roof top.
4. Choose an area of open space in direct sunlight without any obstruction of rain, wind, and sunlight.
5. Transmission range between sensor array and display console could reach a distance of 150m (or 450 feet) at line of sight, providing there are no interfering obstacles in between or nearby such as trees, towers, or high voltage line. Check the reception signal quality to ensure good reception.
6. Household appliance such as fridge, lighting, dimmers may pose Electro-magnetic interference (EMI), while Radio Frequency Interference (RFI) from devices operating in the same frequency range may cause signal intermittent. Choose a location at least 1-2 meter (3-5 feet) away from these interference sources to ensure best reception.

3. GETTING STARTED

3.1 WIRELESS 7-IN-1 SENSOR

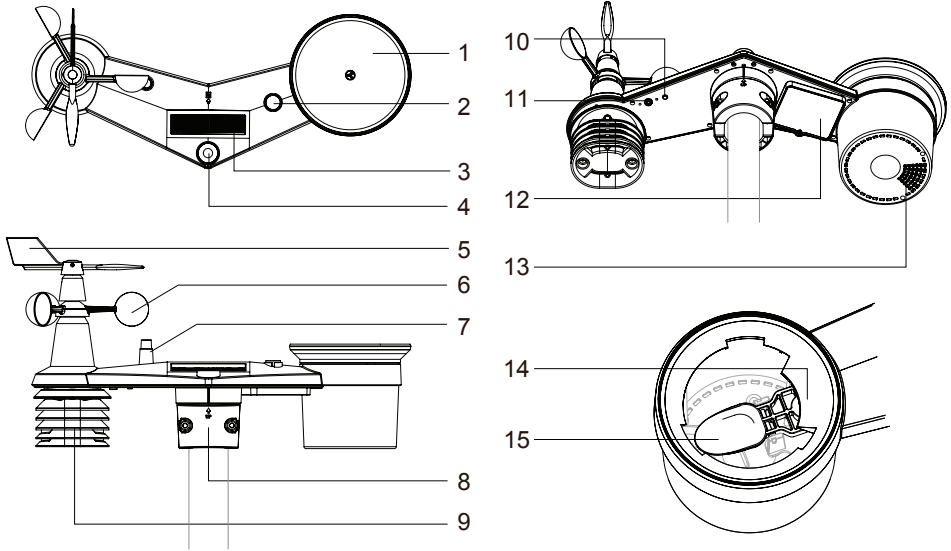

- | | | |
|-----------------------|---|--------------------|
| 1. Rain collector | 7. Antenna | 12. Battery door |
| 2. Balance indicator | 8. Mounting clamp | 13. Drain holes |
| 3. Solar panel | 9. Radiation shield and thermo-hygro sensor | 14. Rain sensor |
| 4. UVI / light sensor | 10. Red LED indicator | 15. Tipping bucket |
| 5. Wind vane | 11. [RESET] key | |
| 6. Wind cups | | |

3.1.1 INSTALL WIND VANE

With reference to photo below, (a) locate and align the flat are on the wind vane shaft to the flat surface on the wind vane and push the vane onto the shaft. (b) tighten the set screw with a precision screwdriver.

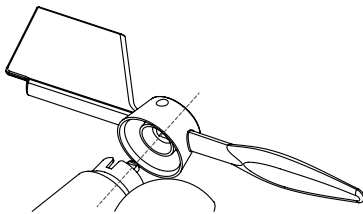

Step 1

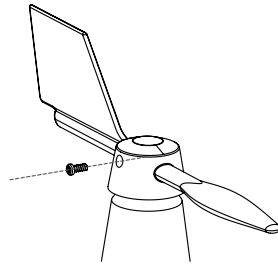

Step 2

3.1.2 INSTALL RAIN GAUGE FUNNEL

Install the rain gauge funnel and rotate clockwise to lock the funnel to the sensor array

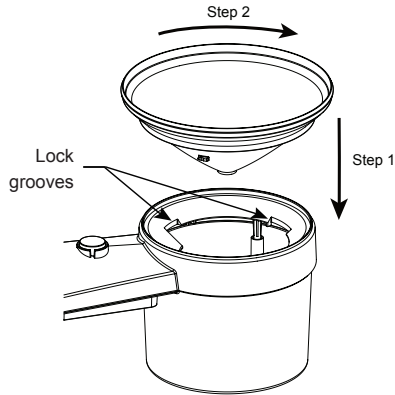

3.1.3 INSTALL BATTERIES

Unscrew the battery door at bottom of unit. Insert the 3 AA batteries (non-rechargeable) according to the +/- polarity indicated. The red LED indicator on the back of the sensor array will turn on, and then begin flashing every 12 seconds.

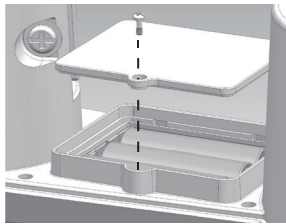

NOTE:

We recommend using non-rechargeable Lithium AA batteries for cold weather climate, but normally Alkaline batteries are sufficient for use in most weather condition.

3.1.4 INSTALL MOUNTING POLE

1. Stick the 2 rubber pads (provided) onto the inner sides of the mounting part
2. Insert the 2 screws into the sensor array mounting base and hand tighten the screws
3. Place the sensor array over the mounting pole and align the sensor array to North direction
4. Tighten the screws to fit the size of your mounting pole

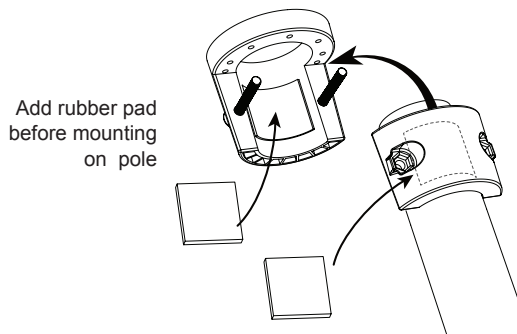

NOTE:

- Any metal object can attract lightning strikes, including your sensor-array mounting pole. Never install sensor-array in stormy days.
- If you want to install a sensor-array on a house or building, consult a licensed electrical engineer to ensure proper grounding. Direct lightning impact on a metal pole can damage or destroy your home.
- Installing the sensor at high location may result in personal injury or death. Perform as many initial inspections and operations as possible on the ground and in buildings or houses. Only install the sensor-array on clear, dry days.

3.1.5 DIRECTION ALIGNMENT

 Install the wireless 7-in-1 sensor in an open location with no obstructions above and around the sensor for accurate rain and wind measurement.

Locate the North (N) marker on top of the 7-in-1 sensor and align the marker to point North upon final installation with a compass or GPS. Tighten the mounting bracket around a 30 to 40 mm diameter pole (not included) using two screw and nuts provided.

Use the bubble level on the 7-in-1 sensor to make sure the sensor is completely level for proper measurement of rainfall, UV and light intensity.

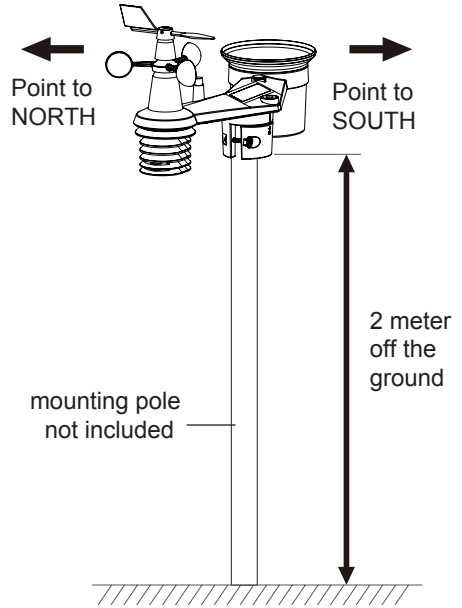

3.1.6 POINTING THE WIRELESS 7-IN-1 SENSOR TO SOUTH

The outdoor 7-IN-1 sensor is calibrated to point to North for the maximum accuracy. However, for the user's convenience (e.g. users in the Southern hemisphere), it is possible to use the sensor with the wind vane pointing to South.

1. Install the 7-IN-1 wireless sensor with its wind meter end pointing to South. (Please refer to **section 3.1.5** for mounting details)
2. Select "S" in hemisphere section of the setup UI setup page. (Please refer to **section 6.3** for setup details)
3. Press  icon to confirm and exit.



NOTE:

Changing the hemisphere setting will automatically switch the direction of the moon phase on the display.

3.2 SYNCHRONIZING ADDITIONAL SENSOR(S) (OPTIONAL)

This console can display the data from additional sensors and upload to ProWeatherLive (PWL) cloud server for user to view the data in PWL website and App. Please contact your local retailer for details of difference sensors.

Some of these sensors are multi-channel. Before inserting the batteries, set the channel number if channel slide switch is located at back of sensors (inside battery compartment). For their operations please refer to the manuals that come with the products.

Model	No of channel	Description	Image
YC85	Up to 7 sensors	Thermo-Hygrometer sensor	
YC74	Up to 4 sensors	PM2.5 / 10 sensor	

3.3 RECOMMENDATION FOR BEST WIRELESS COMMUNICATION

Effective wireless communication is susceptible to noise interference in the environment, and distance and barriers between the sensor transmitter and the display console.

1. Electromagnetic interference (EMI) – these may be generated by machinery, appliances, lighting, dimmers and computers, etc. So please keep your display console 1 or 2 meters away from these items.
2. Radio-frequency interference (RFI) – if you have other devices operating on 868 / 915 / 917 MHz, you might experience communication intermittent. Please re-located your transmitter or display console to avoid signal intermittent problem.
3. Distance. Path loss occurs naturally with distance. This device is rated to 150m (450 feet) by line of sight (in interference free environment and without barriers). However, typically you will get 30m (100 feet) maximum in real life installation, which includes passing through barriers.
4. Barriers. Radio signal are blocked by metal barriers such as aluminum cladding. Please align the sensor array and display console to get them in clear line of sight through window if you have metal cladding.

The table below show a typical level of reduction in signal strength each time the signal passed through these building materials

Materials	Signal strength reduction
Glass (untreated)	10 ~ 20%
Wood	10 ~ 30%
Plasterboard / drywall	20 ~ 40%
Brick	30 ~ 50%
Foil insulation	60 ~ 70%
Concrete wall	80 ~ 90%
Aluminum siding	100%
Metal wall	100%

Remarks: RF signal reduction for reference

3.4 SETUP THE CONSOLE

Follow the procedure to setup the console connection with sensor(s) and WI-FI.

3.4.1 POWER UP THE DISPLAY CONSOLE

1. Install the back-up CR2032 battery

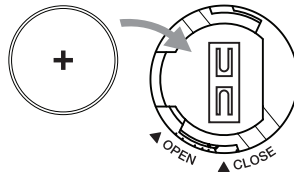

2. Connect the display console power jack to AC power with the adaptor included.

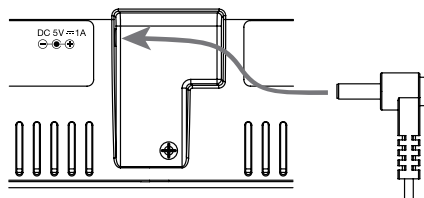

NOTE:

- The backup battery can backup: Time & Date & Max/Min weather records, rainfall records.
- The built-in memory can backup: WI-FI setting, Hemisphere setting, Calibration values, and Sensor ID of paired sensor(s).
- Please always remove the back-up battery if the device is not going to be used for a while. Please keep in mind that even when the device is not in use, certain settings, such as the clock, alert settings and records in its memory, will still drain the back-up battery.

3.4.2 SETUP DISPLAY CONSOLE

1. Once the console power up, all the segments of the LCD will be shown.
2. The console will automatically start AP mode and show the "AP" icon on the screen, you can follow the **section 6** to setup the WI-FI connection.

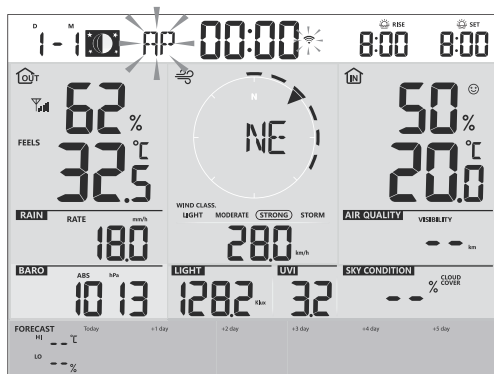

Start up screen (7-in-1 sensor connected)

NOTE:

If no display appears when power up the console, you can press [**RESET**] key by using a pointed object. If this process still not work, you can remove the backup battery and unplug the adapter then re-power up the console again.

3.4.3 SYNCHRONIZING WIRELESS 7-IN-1 SENSOR

Immediately after power up the console, while still in synchronization mode, the 7-in-1 sensor can be paired to the console automatically (as indicated by the flashing antenna ). User may also manually restart the synchronization mode by pressing the [**SENSOR / WI-FI**] key. Once they are paired up, the sensor signal strength indicator and weather reading will appear on your console display.

3.4.4 DATA CLEARING

During installation of the wireless 7-in-1 sensor, the sensors were likely to be triggered, resulting in erroneous rainfall and wind measurements. After the installation, user may clear out all the erroneous data from the display console. Simply press the [**RESET**] key once to re-start the console.

4. DISPLAY CONSOLE FUNCTIONS AND OPERATION

4.1 SCREEN DISPLAY

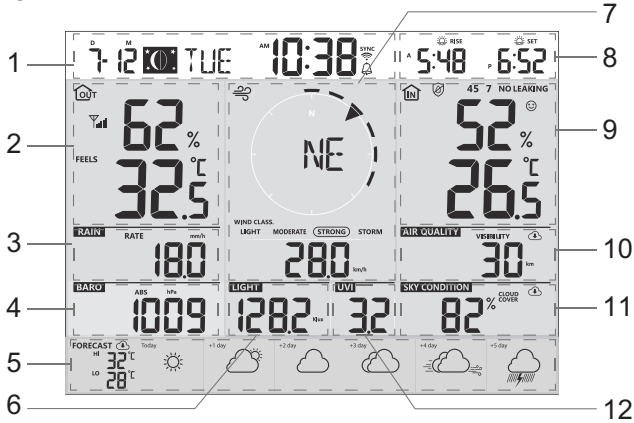

1. Time & Data, Moon phase, Sunrise/ sunset & moon rise / moon set
2. Outdoor temperature & humidity
3. Rainfall & Rain rate
4. Barometer
5. Today and 5 days Weather forecast
6. Light intensity

7. Wind direction & speed
8. Sunrise / sunset & moon rise / moon set
9. Indoor / CH temperature & humidity
10. Air quality
11. Sky condition
12. UV index

4.2 DISPLAY CONSOLE KEYS

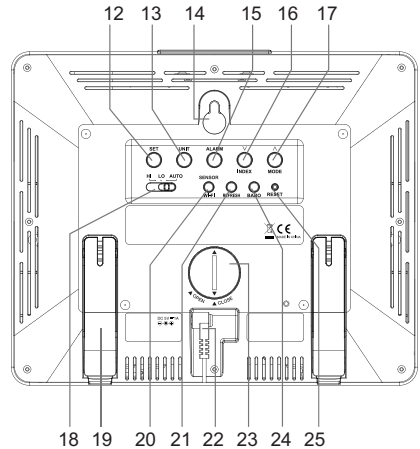
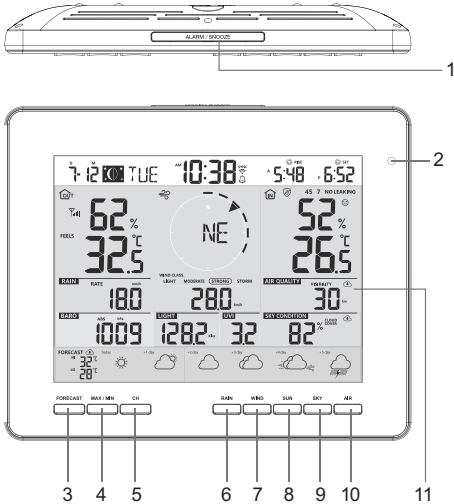















No.	Key / Part Name	Description
1	ALARM/SNOOZE	During alarm, press to stop the alarm, press and hold for 2 seconds to stop current snooze.
2	Ambient light detector	
3	FORECAST	Press to view the HI/LO temperature from today to next 5 days
4	MAX / MIN	Press to switch between maximum and minimum values of Daily and Since last rest
5	CHANNEL	Press this button to switch between indoor and channels readings
6	RAIN	Press to switch between Rain Rate, rainfall
7	WIND	Press to switch between average wind speed, wind gust and Beaufort Scale Press and hold 2 seconds to switch wind direction between language and 360 bearing
8	SUN	Press to switch between Solar Light Intensity and Sunburn time
9	SKY	Press to switch between Cloud Cover Percentage and Lightning Strike
10	AIR	Press to switch between Sky visibility distance and Air quality
11	Display screen	
12	SET	Hold to enter time and date setting Press to toggle sun & moon times
13	UNIT	Hold to enter unit of measurements setting
14	Wall mount hole	
15	ALARM	Hold to enter alarm setting
16	∨ / INDEX	To switch between outdoor temperature, feels like, heat index, dew point and wind chill reading Set the value decrease
17	^ / MODE	To switch between predicted HI & LO temperature, or predicted average temperature & chance of rain Set the value increase
18	HI / LO / AUTO	Slide to select the back light level mode
19	Table stand	
20	SENSOR / WIFI	Press to start sensor synchronization (paring) Press and hold 6 seconds to enter AP mode, vice versa
21	REFRESH	Press to update the upload and download data
22	Power jack	
23	Battery compartment	
24	BARO	To switch between relative and absolute air pressure reading
25	RESET	Press to reset the console Press and hold 6 seconds to factory reset the console

4.3 CONSOLE FEATURES

4.3.1 MULTI-DAY WEATHER FORECAST FOR TODAY & NEXT 5 DAY

Up to 15 different weather icons are provided according to the weather conditions forecasted:

				
Sunny	Partly cloudy	Cloudy / Foggy	Overcast	Windy
				
Light rain	Heavy rain	Partly cloudy with light rain	Partly cloudy with heavy rain	Thundery
				
Thundery showers	Stormy rain	Snowy	Snowy rain	Heavy Snowy rain

Based on the longitude and latitude of the device in your ProWeatherLive account, (refer to PWL setup), the console indicates the weather forecasts of today and next 5 days.

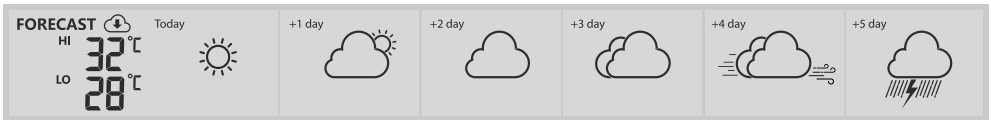



Multi day weather forecast section

Weather forecast with High (HI) and Low (LO) temperatures is default mode in this section, if update is normal, the  icon will appear and update interval is per hour.

4.3.2 HIGH-LOW TEMPERATURE FORECAST FOR TODAY & NEXT 5 DAYS

By default, the console shows the High (HI) and Low (LO) temperatures of current day. To view the HI and LO temperatures from today to the next 5 days, simply press the [FORECAST] key as shown below.

Press 1 time to view today readings		+1 day	+2 day	+3 day	+4 day	+5 day
Press again to view next day readings		+1 day	+2 day	+3 day	+4 day	+5 day
Press again to view third day readings		+1 day	+2 day	+3 day	+4 day	+5 day

4.3.3 AVERAGE TEMPERATURE FORECAST WITH CHANCE OF RAIN FOR TODAY & NEXT 5 DAYS

Instead of HI and LO temperatures, users can change to display Average temperature (AVG) and Chance of Rain of current day, by simply pressing the [^ / MODE] key.



High / Low temperature mode

Avg temperature / chance of rain mode

To view the Average temperatures and Chance of Rain from today to the next 5 days, simply press the [FORECAST] key

Press 1 time to view today readings	<table border="1"> <thead> <tr> <th>FORECAST </th> <th>Today</th> <th>+1 day</th> <th>+2 day</th> <th>+3 day</th> <th>+4 day</th> <th>+5 day</th> </tr> </thead> <tbody> <tr> <td>AVG 26°C</td> <td></td> <td></td> <td></td> <td></td> <td></td> <td></td> </tr> <tr> <td>CHANCE OF RAIN 10%</td> <td></td> <td></td> <td></td> <td></td> <td></td> <td></td> </tr> </tbody> </table>	FORECAST	Today	+1 day	+2 day	+3 day	+4 day	+5 day	AVG 26°C							CHANCE OF RAIN 10%						
FORECAST	Today	+1 day	+2 day	+3 day	+4 day	+5 day																
AVG 26°C																						
CHANCE OF RAIN 10%																						
Press again to view next day readings	<table border="1"> <thead> <tr> <th>FORECAST </th> <th>Today</th> <th>+1 day</th> <th>+2 day</th> <th>+3 day</th> <th>+4 day</th> <th>+5 day</th> </tr> </thead> <tbody> <tr> <td>AVG 25°C</td> <td></td> <td></td> <td></td> <td></td> <td></td> <td></td> </tr> <tr> <td>CHANCE OF RAIN 70%</td> <td></td> <td></td> <td></td> <td></td> <td></td> <td></td> </tr> </tbody> </table>	FORECAST	Today	+1 day	+2 day	+3 day	+4 day	+5 day	AVG 25°C							CHANCE OF RAIN 70%						
FORECAST	Today	+1 day	+2 day	+3 day	+4 day	+5 day																
AVG 25°C																						
CHANCE OF RAIN 70%																						
Press again to view third day readings	<table border="1"> <thead> <tr> <th>FORECAST </th> <th>Today</th> <th>+1 day</th> <th>+2 day</th> <th>+3 day</th> <th>+4 day</th> <th>+5 day</th> </tr> </thead> <tbody> <tr> <td>AVG 25°C</td> <td></td> <td></td> <td></td> <td></td> <td></td> <td></td> </tr> <tr> <td>CHANCE OF RAIN 80%</td> <td></td> <td></td> <td></td> <td></td> <td></td> <td></td> </tr> </tbody> </table>	FORECAST	Today	+1 day	+2 day	+3 day	+4 day	+5 day	AVG 25°C							CHANCE OF RAIN 80%						
FORECAST	Today	+1 day	+2 day	+3 day	+4 day	+5 day																
AVG 25°C																						
CHANCE OF RAIN 80%																						

NOTE:

- This is on-line weather forecast service, please keep the console connected to ProWeatherLive, you can refer to section 5 and 6 for the WI-FI and PWL setup.
- Please input correct location for your device in ProWeatherLive "Edit device" page.
- If the Wi-Fi connectivity is not stable for over 3 hours, the weather forecast, cloud cover and visibility will not be shown, and the icon will disappear.

4.3.4 OUTDOOR TEMPERATURE, HUMIDITY & TEMPERATURE INDEX

1. Outdoor sensor signal indicator to show the signal receiving strength
2. Outdoor sensor low battery indicator
3. Temperature index mode indicator
4. Outdoor Humidity reading
5. Outdoor Temperature reading

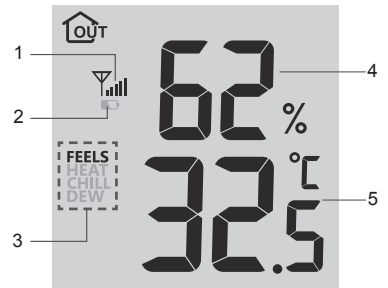

NOTE:

- If temperature / humidity is below the measurement range, the reading will show "Lo". If temperature / humidity is above the measurement range, the reading will show "Hi".
- Press [v / INDEX] key to switch between Outdoor temperature, Feels Like, Heat Index, Wind Chill, and Dew Point.

4.3.4.1 FEELS LIKE

Feels Like Temperature shows what the outdoor temperature will feel like. It's a collective mixture of Wind Chill factor (18°C or below) and the Heat Index (26°C or above). For temperatures in the region between 18.1°C to 25.9°C where both wind and humidity are less significant in affecting the temperature, the device will show the actual outdoor measured temperature as Feels Like Temperature.

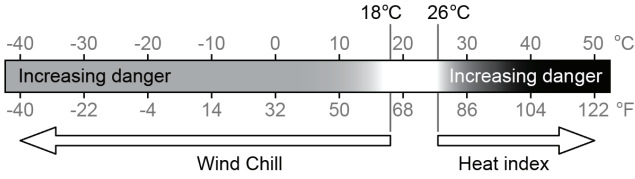

4.3.4.2 HEAT INDEX

The heat index which is determined by the wireless 7-IN-1 sensor's temperature & humidity data when the temperature is between 26°C (79°F) and 50°C (120°F).

Heat Index range	Warning	Explanation
27°C to 32°C (80°F to 90°F)	Caution	Possibility of heat exhaustion
33°C to 40°C (91°F to 105°F)	Extreme Caution	Possibility of heat dehydration
41°C to 54°C (106°F to 129°F)	Danger	Heat exhaustion likely
≥55°C (≥130°F)	Extreme Danger	Strong risk of dehydration / sun stroke

4.3.4.3 WIND CHILL

A combination of the wireless 7-IN-1 sensor's temperature and wind speed data determines the current wind chill factor. Wind chill number are always lower than the air temperature for wind values where the formula applied is valid (i.e. due to limitation of formula, actual air temperature higher than 10°C with wind speed below 9 km/h may result in erroneous wind chill reading).

4.3.4.4 DEW POINT

- The dew point is the temperature below which the water vapor in air at constant barometric pressure condenses into liquid water at the same rate at which it evaporates. The condensed water is called *dew* when it forms on a solid surface.
- The dew point temperature is determined by the temperature & humidity data from wireless 7-IN-1 sensor.

4.3.5 INDOOR / CHANNELS TEMPERATURE & HUMIDITY

This section can show reading and status of the indoor, optional hygro-thermo sensor(s) and water leak sensor(s).

4.3.5.1 OVERVIEW

1. Auto loop icon
2. Indoor icon
3. Channel number and sensor signal strength icon
4. Channel sensor low battery indicator
5. Floating pool sensor icon
6. Soil moisture sensor icon
7. Water leak sensor status section
8. Comfort indication icons
9. Humidity reading section
10. Temperature reading section

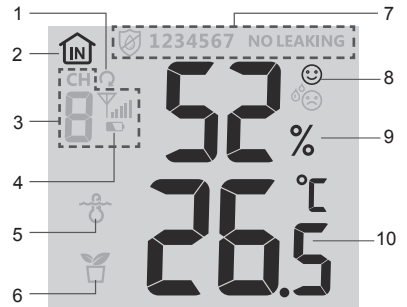

4.3.5.2 INDOOR TEMPERATURE & HUMIDITY

The indoor reading is default mode of the console.

This mode shown below information:

- Comfort indication
- Temperature and humidity reading of indoor

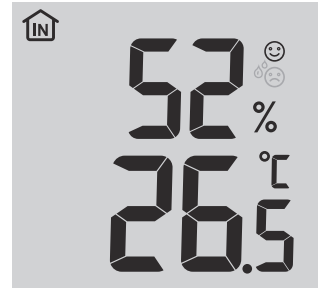

4.3.6 MULTI-CHANNEL AND SCROLL MODE FOR OPTIONAL SENSORS

You can add up to 7 additional Thermo-Hygrometer sensor (optional, refer to **section 3.2** Press the [CH] key to switch between indoor and Channels 1 to 7.

For auto-scroll function, just press and hold the [CH] key for 3 seconds and the  icon will appear next to CH. The console will scroll the readings of all the sensors every 3 seconds.

NOTE:

For multi-channel sensor data, it will only be upload to ProWeatherLive server, and no history data will be saved in the console.

This mode shown below information:

- Channel number of the current sensor
- Comfort indication of this sensor
- Temperature and humidity reading of this sensor
- Signal strength of this sensor.
- Sensor type icon (for water pool or soil moisture sensor)

4.3.7 WATER LEAK (OPTIONAL LEAK SENSOR)

You can add up to 7 additional Water Leak sensors (optional, refer to **section 3.2**.

The channel number(s) of the corresponding water leak sensor(s) added to the console will be shown with the NO LEAKING icon.

When water leaking is detected, the channel number of the sensor detecting the leaking will flash together the LEAKING icon.



NOTE:

When low battery is detected, the channel number of the sensor detecting the low battery condition will flash once every 4 seconds.

4.3.8 WIND

4.3.8.1 WIND SPEED AND DIRECTION SECTION OVERVIEW

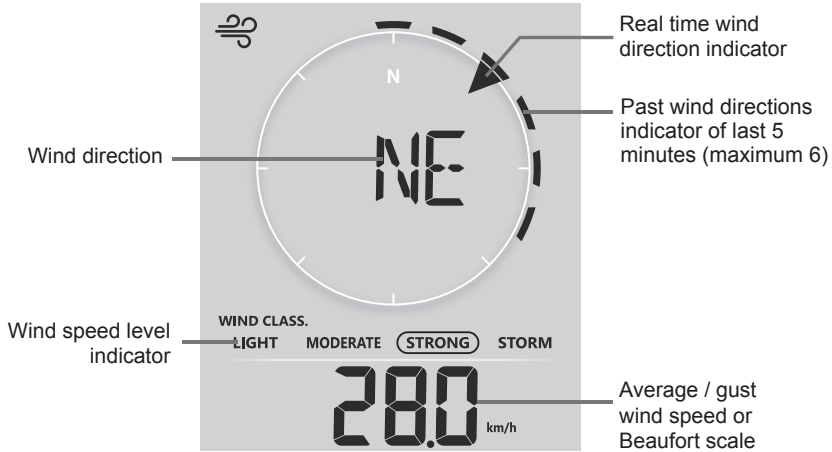

A solid arrow indicates the current real-time wind direction, whereas the bars indicate up to six different wind direction of the past 5 minutes.

4.3.8.2 WIND SPEED, GUST AND BEAUFORT SCALE DISPLAY

Press **[WIND]** key to switch display between Average wind speed, Gust, and Beaufort scale. The wind level provides a quick reference on the wind condition and is indicated by a series of text icons

Level	LIGHT	MODERATE	STRONG	STORM
Speed	2-8 mph 3-13 km/h	9-25 mph 14-41 km/h	26-54 mph 42-87 km/h	≥ 55 mph ≥ 88 km/h

NOTE:

- Windspeed is defined as the average wind speed in the 12 second update period
- Gust is defined as the peak wind speed in the 12 second update period

4.3.8.3 WIND DIRECTION IN 16-POINT DIRECTIONS AND DEGREES

By default, wind direction is displayed by a 16-point compass, which include N, E, S, W, NE, NW, SE, SW, NNE, ENE, SSE, ESE, NNW, WNW, SSW, WSW.

User can change to wind direction shown in 360 degrees.

Press and hold **[WIND]** key for 2 seconds until the wind direction is flashing. Press **[▲ / FORECAST]** or **[▼ / INDEX]** key to select the display format between 16-point direction and 360 degrees.

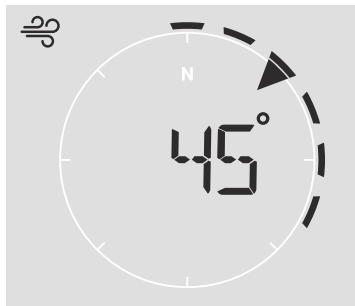

4.3.8.4 BEAUFORT SCALE TABLE

The Beaufort scale is an international scale of wind velocities ranging from 0 (calm) to 12 (Hurricane force).

Beaufort Scale	Description	Wind Speed	Land Condition
0	Calm	< 1 km/h	Calm. Smoke rises vertically.
		< 1 mph	
		< 1 knots	
		< 0.3 m/s	
1	Light air	1.1 ~ 5km/h	Smoke drift indicates wind direction. Leaves and wind vanes are stationary.
		1 ~ 3 mph	
		1 ~ 3 knots	
		0.3 ~ 1.5 m/s	
2	Light breeze	6 ~ 11 km/h	Wind felt on exposed skin. Leaves rustle. Wind vanes begin to move.
		4 ~ 7 mph	
		4 ~ 6 knots	
		1.6 ~ 3.3 m/s	
3	Gentle breeze	12 ~ 19 km/h	Leaves and small twigs constantly moving, light flags extended.
		8 ~ 12 mph	
		7 ~ 10 knots	
		3.4 ~ 5.4 m/s	
4	Moderate breeze	20 ~ 28 km/h	Dust and loose paper raised. Small branches begin to move.
		13 ~ 17 mph	
		11 ~ 16 knots	
		5.5 ~ 7.9 m/s	
5	Fresh breeze	29 ~ 38 km/h	Branches of a moderate size move. Small trees in leaf begin to sway.
		18 ~ 24 mph	
		17 ~ 21 knots	
		8.0 ~ 10.7 m/s	
6	Strong breeze	39 ~ 49 km/h	Large branches in motion. Whistling heard in overhead wires. Umbrella use becomes difficult. Empty plastic bins tip over.
		25 ~ 30 mph	
		22 ~ 27 knots	
		10.8 ~ 13.8 m/s	
7	High wind	50 ~ 61 km/h	Whole trees in motion. Effort needed to walk against the wind.
		31 ~ 38 mph	
		28 ~ 33 knots	
		13.9 ~ 17.1 m/s	
8	Gale	62 ~ 74 km/h	Some twigs broken from trees. Cars veer on road. Progress on foot is seriously impeded
		39 ~ 46 mph	
		34 ~ 40 knots	
		17.2 ~ 20.7 m/s	
9	Strong gale	75 ~ 88 km/h	Some branches break off trees, and some small trees blow over. Construction / temporary signs and barricades blow over.
		47 ~ 54 mph	
		41 ~ 47 knots	
		20.8 ~ 24.4 m/s	
10	Storm	89 ~ 102 km/h	Trees are broken off or uprooted, structural damage likely.
		55 ~ 63 mph	
		48 ~ 55 knots	
		24.5 ~ 28.4 m/s	
11	Violent storm	103 ~ 117 km/h	Widespread vegetation and structural damage likely.
		64 ~ 73 mph	
		56 ~ 63 knots	
		28.5 ~ 32.6 m/s	

12	Hurricane force	≥ 118 km/h	Severe widespread damage to vegetation and structures. Debris and unsecured objects are hurled about.
		≥ 74 mph	
		≥ 64 knots	
		≥ 32.7m/s	

4.3.9 BAROMETRIC PRESSURE

The atmospheric pressure is the pressure at any location of the earth caused by the weight of the column of air above it. One atmospheric pressure refers to the average pressure and gradually decreases as altitude increases. Meteorologists use barometers to measure atmospheric pressure. Because absolute atmospheric pressure decreases with altitude, meteorologist correct the pressure relative to sea-level conditions. Hence, your ABS pressure may read 1000 hPa at altitude of 300m, but the REL pressure is 1013 hPa.

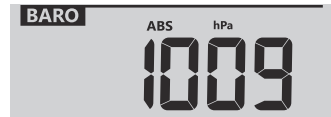

To obtain accurate REL pressure for your area, consult your local official observatory or check weather website on internet for real time barometer conditions, and then adjust the relative pressure in SETUP (section 6.4.1)

4.3.9.1 ABSOLUTE OR RELATIVE BAROMETRIC PRESSURE MODE

In normal mode, press [**BARO**] key to switch between ABSOLUTE and RELATIVE barometric pressure.

4.3.10 RAIN

The **RAINFALL** section shows the rainfall or rain rate information.

4.3.10.1 THE RAINFALL DISPLAY MODE

Press [**RAIN**] key to toggle between:

1. **RATE** - Current rainfall rate (base on 10 min rain data)
2. **HOURLY** - the total rainfall in the past hour
3. **DAILY** - the total rainfall from midnight (default)
4. **WEEKLY** - the total rainfall of the current week
5. **MONTHLY**- the total rainfall of the current calendar month
6. **TOTAL** - the total rainfall since the last reset

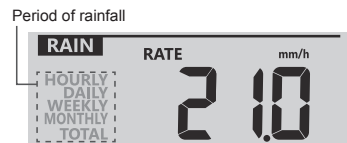

4.3.10.2 TO RESET THE TOTAL RAINFALL RECORD

In normal mode, press and hold [**RAIN**] key for 2 seconds to reset all the rainfall record.

NOTE:

Erroneous readings may occur during the installation of the 7-in-1 sensor array. Once the installation is completed and functioning correctly, it's advisable to clear all the data and start afresh.

4.3.11 LIGHT INTENSITY, UV INDEX & SUNBURN TIME

This section of display show the sunlight intensity, UV index and sunburn time.

4.3.11.1 SOLAR LIGHT INTENSITY & SUNBURN TIME MODE:

During light intensity mode, press [**SUN**] key to switch between sunlight intensity and sunburn time

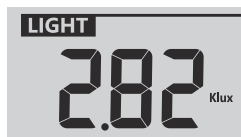

Light intensity mode

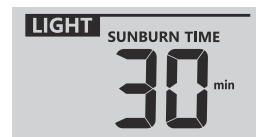

Sunburn time mode

UV INDEX VS SUNBURN TIME TABLE

Exposure level	Low		Moderate			High		Very high			Extreme	
UV index	1	2	3	4	5	6	7	8	9	10	11	12~16
Sunburn time	N/A		45 minutes			30 minutes		15 minutes			10 minutes	
Recommended protection	N/A		Moderate or high UV level! Suggest to wear sunglasses, broad brim hat and long-sleeved clothing.				Very high or Extreme UV level! Suggest to wear sunglasses, broad brim hat and long-sleeved clothing. If you have to stay outdoors, make sure to seek shade.					

NOTE:

- The sunburn time is based on normal skin type, it is just a reference of UV strength. In general, the darker one's skin is, the longer (or more radiation) it takes to affect the skin.
- The light intensity function is for sunlight detection.

4.3.11.2 UV INDEX MODE

To show the current UV index detected by the outdoor sensor.



4.3.12 AIR QUALITY

Air quality section shows the visibility distance according to the device location input in PWL. If you have optional PM2.5/10 sensor(s), you can also view the corresponding data in this section.

4.3.12.1 VISIBILITY MODE

Air visibility is measured in distance (either in km or miles), and is generally refer to the distance at which an object or light can be clearly discerned, and it depends on the transparency of the surrounding air. Visibility range can reach over 50km on exceptionally clear day, down to under 1km on hazy day.



If the WiFi connectivity is not stable for over 3 hours, the air visibility will not be shown, and the  icon will disappear.

4.3.12.2 PM2.5/10 MODE (OPTIONAL SENSOR)

This console support up to 4 optional PM2.5 /10 sensors for you to detect different area's air quality. If you paired this sensor, you can press the [AIR] key to check the reading in the following display sequence: Visibility → CH1 → CH2 → CH3 → CH4 PM2.5/10 sensor's reading.



4.3.12.3 ACTIVATE THE AUTO LOOP IN AIR QUALITY SECTION

To activate the auto-loop function in this section, just press and hold the [AIR] key for 2 seconds and the  icon will show near the CH number and display the connected channels' reading at 4 seconds interval.

4.3.12.4 VIEW DIFFERENT READING OF PM2.5 / 10

The PM2.5 /10 sensor can provide different air quality readings, you can press [UNIT] key to check reading in the following display sequence: PM2.5 → PM10 → PM2.5 AQI → PM10 AQI.

NOTE:

The PM2.5 / 10 sensor is optional sensor, which is not included.

4.3.13 SKY CONDITION

Sky condition section show the % of cloud cover according to the device location input in PWL. If you have optional lightning sensor, you can also view the lightnings detected instantly.

4.3.13.1 CLOUD COVER MODE

Cloud cover is an important component of understanding and predicting the weather. Not only does cloud cover impact sky conditions and inform precipitation predictions, it also helps regulate the temperature that occurs in a region.

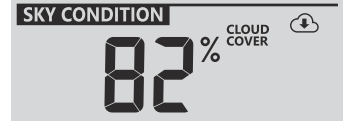

If the WiFi connectivity is not stable for over 3 hours, the cloud cover will not be shown, and the  icon will disappear.

4.3.13.2 LIGHTNING DETECT MODE (OPTIONAL SENSOR)

Lightning detect C3129A is an optional sensor user could purchase separately and paired with the weather station console. It enables real-time viewing of lightning data on the display.

When lightning strike is detected, red light will flash on the sensor.



Number of strikes in last hour

On the console, press [**SKY**] button to view the following lightning information

- Period of time since last lightning, and estimated lightning distance
- Number of light per hour.
- Return to Cloud Cover.



Last lightning time and distance

4.3.13.3 ACTIVATE THE AUTO LOOP IN SKY CONDITION SECTION





To activate the auto-loop function in this section, just press and hold the [**AIR**] key for 2 seconds and the  icon will show near the CH number and display the connected channels' reading at 4 seconds interval.

NOTE:

The lightning sensor is optional sensor, which is not included.

4.3.14 MAXIMUM / MINIMUM RECORDS

The console can record MAX / MIN readings both daily and since last reset.

 MAX	 MIN	 MAX	 MIN
Daily MAX reading	Daily MIN reading	MAX reading since last reset	MIN reading since last reset

4.3.14.1 DAILY AND SINCE MAX / MIN RECORDS

In normal mode, press [**MAX / MIN**] key to check the records of the on screen reading in the following display sequence: daily MAX records → daily MIN records → since MAX records → since MIN records.

4.3.14.2 TO CLEAR THE MAX/MIN RECORDS

Press and hold [**MAX / MIN**] key for 2 seconds to reset all the MAX and MIN records.

4.3.15 MOON PHASE

The moon phase is determined by time and date of the console. The following table explains the moon phase icons of the Northern and Southern Hemispheres. Please refer to **section 6.3** web interface about how to setup for the Southern Hemisphere.

Northern Hemisphere	Moon Phase	Southern Hemisphere
	New Moon	
	Waxing Crescent	
	First quarter	
	Waxing Gibbous	
	Full Moon	
	Waning Gibbous	
	Third quarter	
	Waning Crescent	

4.3.16 SUNRISE / SUNSET & MOON RISE / MOON SET TIME

 RISE A 5:48 P 6:52	 RISE P 5:00 A 5:30
Sunrise / sunset time	Moon rise / moon set time

The console indicates your location's sunrise / sunset & moon rise / moon set times on the top right corner of the display, which is based on time zone, latitude and longitude of your device input in PWL.

4.3.17 WIRELESS SENSOR SIGNAL RECEIVING

1. The console display signal strength for the wireless sensor(s), as per table below:

	No signal	Weak signal	Good signal
Outdoor 7-in-1 sensor			
Hydro-thermal sensor channel	CH	CH	CH
Other optional sensor			

- If the signal has discontinued and does not recover within 15 minutes, the signal icon will disappear. The temperature and humidity will display "Er" for the corresponding channel.
- If the signal does not recover within 48 hours, the "Er" display will become permanent. You need to replace the batteries and then press [**SENSOR / WI-FI**] key to pair up the sensor again.

4.3.18 TIME SYNCHRONIZE STATUS



After the console has connected to the PWL, it can get the time from PWL that according to your selected time zone in PWL. The "SYNC" icon will appear on the LCD.



The time will automatically synchronize per hour. You can also press the [**REFRESH**] key to get the Internet time manually within 1 minute.

4.3.19 WI-FI CONNECTION STATUS

WI-FI icon on the console display indicates the console's connection status with WI-FI router.

	
Stable: Console is in connection with WI-FI router	Flashing: Console is trying to connect to WI-FI router

4.4 OTHER SETTING

4.4.1 TIME, DATE AND GENERAL SETTING

Press and hold the [**SET**] key for 2 seconds to enter the SET mode. Press [**▲ / FORECAST**] or [**▼ / INDEX**] to adjust, and press [**SET**] to proceed with next step of the setting. Please refer to following setting procedures.

Step	Mode	Setting procedure
1	Hour	Press [▼ / INDEX] or [▲ / MODE] key to adjust the hour
2	Minute	Press [▼ / INDEX] or [▲ / MODE] key to adjust the minute
3	12/24 hour format	Press [▼ / INDEX] or [▲ / MODE] key to select 12 or 24 hour format
4	Year	Press [▼ / INDEX] or [▲ / MODE] key to adjust the year
5	Month	Press [▼ / INDEX] or [▲ / MODE] key to adjust the month
6	Day	Press [▼ / INDEX] or [▲ / MODE] key to adjust the day
7	M-D/D-M format	Press [▼ / INDEX] or [▲ / MODE] key to select "Month / Day" or "Day / Month" display format
8	Select Sunrise / Sunset or Moon rise / Moon set display	Press [▼ / INDEX] or [▲ / MODE] key to select Sunrise / Sunset or Moon rise / Moon set display
9	Time sync ON/OFF	Press [▼ / INDEX] or [▲ / MODE] key to enable or disable time sync function. If you want to set the time manually, you should set time sync OFF
10	Weekday language	Press [▼ / INDEX] or [▲ / MODE] key to select weekday display language

NOTE:

- In normal mode, press [**SET**] key to switch between year and date display.
- During the setting, you can back to normal model by press and hold [**SET**] key for 2 seconds.

4.4.2 SETTING ALARM TIME

1. In normal time mode, press and hold [**ALARM**] key for 2 seconds until the alarm hour digit flashes to enter alarm time setting mode.
2. Press [**▼ / INDEX**] or [**▲ / MODE**] key to change the value. Press and hold the key for quick-adjust.
3. Press [**ALARM**] key again to step the setting value to Minute with the Minute digit flashing.
4. Press [**▼ / INDEX**] or [**▲ / MODE**] key to adjust the value of the flashing digit.
5. Press [**ALARM**] key to save and exit the setting.

NOTE:

- In alarm mode, the "  " icon will display on the LCD.
- The alarm function will turn on automatically once you set the alarm time.

4.4.2.1 ACTIVATING ALARM AND TEMPERATURE PRE-ALARM FUNCTION

1. In normal mode, press [**ALARM**] key to show the alarm time for 5 seconds.
2. When the alarm time displays, press [**ALARM**] key again to activate the alarm function. Or press [**ALARM**] key twice to activate the alarm with ice pre-alarm function.

		
Alarm off	Alarm on	Alarm with ice-alert

NOTE:

Once the ice pre-alert activates, the pre-set alarm will sound and ice-alert icon will flash 30 minutes earlier if the outdoor temperature is below -3°C.

When clock reach the alarm time, alarm sound will start.

Where it can be stopped by following operation:

- Auto-stop after 2 minutes alarming if without any operation and the alarm will activate again in the next day.
- By pressing [**ALARM / SNOOZE**] key to enter snooze that the alarm will sound again after 5 minutes.
- By pressing and hold [**ALARM / SNOOZE**] key for 2 seconds to stop the alarm and will activate again in the next day
- By pressing [**ALARM**] key to stop the alarm and the alarm will activate again in the next day.

NOTE:

- The snooze could be used continuously in 24 hours.
- During the snooze, the alarm icon "  " will keep flashing.

4.4.3 UNIT SETTING

Use the [**UNIT**] key to change the unit of the readings on the console display.

Below is the operation step:

- Press and hold [**UNIT**] key for 2 seconds to enter the unit setting mode.
- Short press [**UNIT**] key to proceed to the next setting step.
- Press [**▲ / FORECAST**] or [**▼ / INDEX**] key to change the value. Press and hold the key for quick-adjust.
- Press and hold [**UNIT**] key for 2 seconds to exit the unit setting mode at any time.

Setting items table:

Step	Mode	Setting procedure
1s	Temperature unit	Press [▼ / INDEX] or [▲ / MODE] key to select °C or °F
2	Rain unit	Press [▼ / INDEX] or [▲ / MODE] key to select mm or in
3	Wind speed unit	Press [▼ / INDEX] or [▲ / MODE] key to select m/s, km/h, knots or mph
4	Distance unit	Press [▼ / INDEX] or [▲ / MODE] key to select k/m or mi (miles)
5	Baro pressure unit	Press [▼ / INDEX] or [▲ / MODE] key to select hPa, inHg or mmHg
6	Light intensity	Press [▼ / INDEX] or [▲ / MODE] key to select Klux, Kfc or W/m ²

4.4.4 BACK LIGHT

The main unit back light can be adjust, using the [**HI / LO / AUTO**] sliding switch to select the appropriate brightness:

- Slide to the [**HI**] position for the brighter back light.
- Slide to the [**LO**] position for the dimmer back light.
- Slide to the [**AUTO**] position for the auto adjust back light that according to environment light level

5. CREATE PWL ACCOUNT & SETUP WI-FI CONNECTION OF CONSOLE

The console can upload /download weather data in ProWeatherLive (PWL) cloud server through WI-FI router, you can follow the step below to setup your device.

NOTE:

ProWeatherLive (PWL) website and APP are subjected to change without notice.

5.1 CREATE PWL ACCOUNT AND ADD NEW DEVICE IN PWL

1. In <https://proweatherlive.net> click the "Create Your Account" then follow the instructions to create your account.

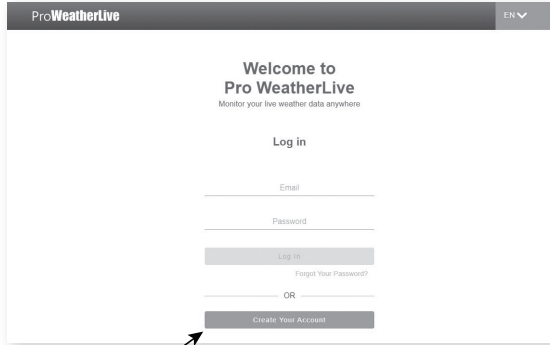

2. Log in the ProWeatherLive and then click the "Edit Devices" in the pull down menu.

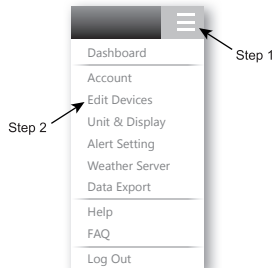

3. In "Edit Devices" page, click the " +Add " on the top right corner to create a new device, it will generate the station ID and key instantly, jot down both and then click " FINISH " to create the station tab.

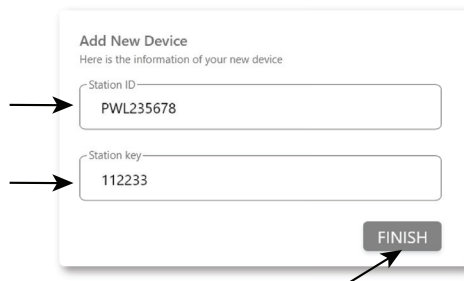

4. Click the " **Edit** " on the top right corner of the station tab.

Q View	Updated :	Cancel	Confirm
Device name :	_____	Time zone :	Europe/xxxxx ▾
Device type :	_____	Elevation :	_____ m
Device MAC :	e.g. 00 : 00 : 00 : 00 : 00 : 00	Latitude :	_____
Station ID :	PWL235678	Longitude :	_____
Station key :	112233	Privavy :	Nobody ▾

5. Enter the "Device name", "Device MAC address", "Elevation", "Latitude", "Longitude" and select your time zone in the station tab, then click "confirm" to save the setting.

Q View	Updated :	Cancel	Confirm
Device name :	My home station	Time zone :	Europe/xxxxx ▾
Device type :	Multi-day forecast weather station	Elevation :	10 m
Device MAC :	00 : 0E : C6 : 00 : 07 : 10	Latitude :	xx.xxxx
Station ID :	PWL235678	Longitude :	xx.xxxx
Station key :	112233	Privavy :	Nobody ▾

 **NOTE:**

Enter a negative sign for Latitudes or Longitudes when it's South or West respectively. For example, 33.8682 South is "-33.8682" ; 74.3413 West is "-74.3413"

The device Mac address can be found on the backside of the console or in the "SETUP" page mentioned in **section 6.3**.

The weather forecast and weather condition will be based on the Latitudes and Longitudes entered, which are also used for calculations of sunrise, sunset, moon rise and moon set times.

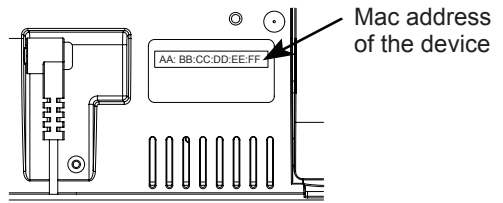

E.g. Device Mac address

6. In the "SETUP" page mentioned in **section 6.3**, key-in the Station ID and key assigned by ProWeatherLive.

Weather server setup	
ProWeatherLive	
Station ID:	PWL2345678
Station key:	112233

6. CONNECT CONSOLE TO WI-FI

6.1 CONSOLE IN ACCESS POINT MODE

When you power up the console for the first time, the console LCD will show flashing "AP" and "Wi-Fi" icon to signify that it has entered AP (Access Point) mode, and is ready for WI-FI settings. User can also press and hold the [**SENSOR / WI-FI**] key for 6 seconds to enter AP mode manually.



6.2 CONNECT TO THE CONSOLE

1. Use PC/Mac, smart phone or tablet to connect with the console through WI-FI network setting.
2. In PC/Mac WI-FI network settings, or In Android / iOS smart phones setting → connect WI-FI to the console's PWS WI-FI network as shown in figures below (console WI-FI network name will always begin with PWS-) :

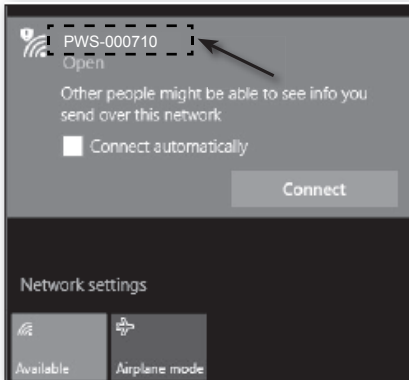

E.g. PC Wi-Fi network interface

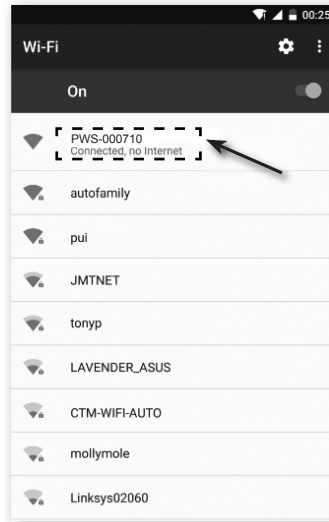

E.g. Android smart phone Wi-Fi network interface

3. Once connected, enter the following IP address into your Internet browser's address bar, to access the console's SETUP web interface:

http://192.168.1.1

NOTE :

- Some browsers will treat **192.168.1.1** as a search, so make sure you include header **http://**.
- If you cannot enter the console's web interface, please turn off the mobile data / network in you smart phone and try again.
- Recommended browsers include the latest version of Chrome, Safari, Edge, Firefox or Opera.
- WI-FI network interface of PC/Mac or smart phone may subject to change.

6.3 SETUP THE WEATHER SERVER CONNECTION

Enter the information into the following web interface "SETUP" page. Ensure all information is entered prior to pressing **Apply** to connect the console to ProWeatherLive.

The screenshot shows the 'SETTINGS' page with the 'SETUP' tab selected. The page is divided into two main sections: 'WiFi Router setup' and 'Weather server setup'. Callouts provide instructions for various fields and buttons:

- Language:** English (dropdown) - Select setup UI display language
- WiFi Router setup:**
 - Search** button - Press to search router
 - Add Router** button - Press to allow add router manually
 - Router:** ROUTER_A (dropdown) - Select router (SSID) for connection
 - Security type:** WAP2 (dropdown) - Select router's security type
 - Router Password:** (text field) - Router password (leave blank if the security type is "Open")
- Weather server setup:**
 - ProWeatherLive** header
 - Station ID:** PWL2345678 (text field) - Enter station ID and key assigned by the ProWeatherLive (PWL)
 - Station key:** 112233 (text field)
 - Mac address:** 00:0E:C6:00:07:10 - Device Mac address
 - Outdoor sensor direction:** Point to: N (dropdown) - Select the sensor located hemisphere (e.g. US and EU countries are "N" Australia is "S")
- Current firmware version:** Firmware version: 1.00
- Apply** button - Press to complete the WI-FI related setting

SETUP page

NOTE:

- If you don't have station ID and station key available for the upload, you need to first create an account at ProWeatherLive (PWL), followed by registering the product to obtain the ID and key. For details, please refer to "Create PWL account and add new device in PWL" in **section 5**.
- When WI-FI setup is completed, your PC/Mac or smart phone will resume its default WI-FI connection.
- During AP mode, you can press and hold the [**SENSOR / WI-FI**] key for 6 seconds to stop AP mode and the console will restore your previous setting.
- Changing the hemisphere setting will automatically switch the direction of the moon phase on the display.

6.4 ADVANCE SETTING IN WEB INTERFACE

Press **"ADVANCED"** key at the top of web interface to enter the advance setting page, this page allow you to set and view the calibration data of the console, as well as update the firmware version on PC/Mac web browser.

SETTINGS

SETUP **ADVANCED**

Press "SETUP" icon to setup page

Select setting unit

	Temperature °C	Humidity %
Indoor	<input type="text"/> Current offset: 0	<input type="text"/> Current offset: 0
Outdoor	<input type="text"/> Current offset: 0	<input type="text"/> Current offset: 0
CH 1	<input type="text"/> Current offset: 0	<input type="text"/> Current offset: 0
CH 2	<input type="text"/> Current offset: 0	<input type="text"/> Current offset: 0
CH 3	<input type="text"/> Current offset: 0	<input type="text"/> Current offset: 0
CH 4	<input type="text"/> Current offset: 0	<input type="text"/> Current offset: 0
CH 5	<input type="text"/> Current offset: 0	<input type="text"/> Current offset: 0
CH 6	<input type="text"/> Current offset: 0	<input type="text"/> Current offset: 0
CH 7	<input type="text"/> Current offset: 0	<input type="text"/> Current offset: 0

In/Outdoor & CH 1~7 temperature calibration section

In/Outdoor & CH 1~7 humidity calibration section

Range: -20.0 ~ 20.0°C
-36.0 ~ +36.0°F (Default: 0.0)

Range: -20 ~ 20%
(Default: 0.0)

Select setting unit

Pressure hpa

Absolute Pressure Offset: Current offset: 0 (Default: 0)

Relative Pressure Offset: Current offset: 0 (Default: 0)

Setting Range: -560 ~ 560hpa / -16.54 ~ 16.54inHg / -420 ~ 420mmHg

Pressure calibration section

Current offset value is the value that you set before to offset the pressure reading

*Rain gain: Current gain: 1.00
Range: 0.5 ~ 1.5(Default: 1.00)

*Wind speed gain: Current gain: 1.00
Range: 0.5 ~ 1.5(Default: 1.00)

*Wind direction: Current offset: +0°
Range: -90 ~ 90(Default: 0°)

*UV gain: Current gain: 1.00
Range: 0.01 ~ 10(Default: 1.00)

*Light gain: Current gain: 1.00
Range: 0.01 ~ 10(Default: 1.00)

*PM2.5: Current offset: 0
Range: -99 ~ 99(Default: 0)

*PM10: Current offset: 0
Range: -99 ~ 99(Default: 0)

The rain, wind speed, UV and light calibration use gain method. The wind direction is +/- 90 offset

The PM2.5 and PM10 is +/-99 offset (PM2.5 /10 calibration setting is for optional sensor only)

* Depends on the model

Current firmware version

Firmware version: 1.00

Browse

Upload

The firmware update function only available in PC/Mac web browser

ADVANCED page

6.4.1 CALIBRATION

1. User can input the offset and/or gain values for different parameters while current offset and gain values are shown next to their corresponding blank.
2. Once completed, press **Apply** at the bottom of the SETUP page

The current offset value will show the previous value that you entered, please input the new value in the blank if any changes needed, the new value will effective once you press **Apply** icon in SETUP page.

NOTE:

Calibration of most parameter is not required, with the exception of Relative Pressure, which must be calibrated to sea-level to account for altitude effects.

7. PROWEATHERLIVE (PWL) LIVE DATA & OPERATION

7.1 VIEW LIVE DATA

Login your ProWeatherLive account.

Once your device is connected, your device's live weather data will show on the dashboard page.

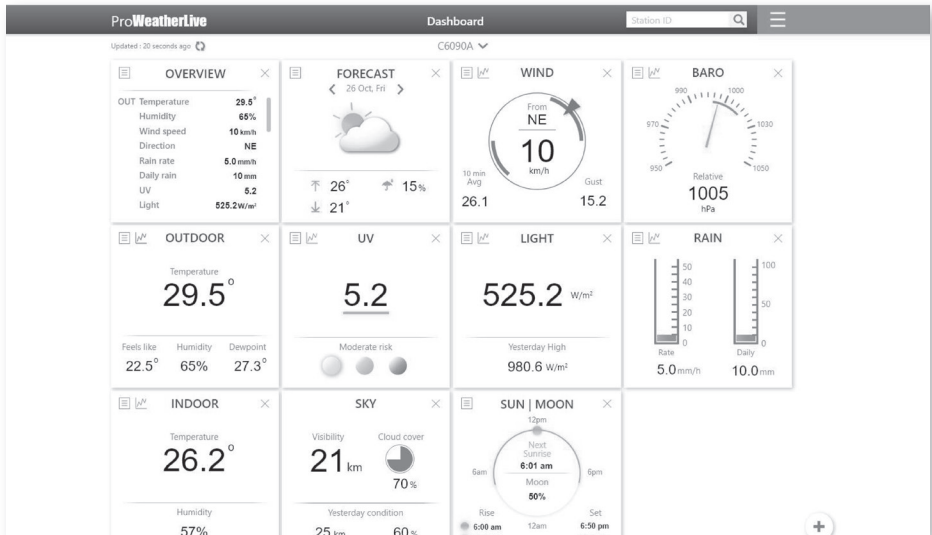

NOTE:

Please press "Help" in the  should you have any query on the PWL operation.

7.2 UPLOAD TO OTHER WEATHER SERVERS

The ProWeatherLive.net service allows data from each weather station to be upload to other 2 weather servers, such as WeatherUnderground, WeatherCloud, PWSWeather, or AWEKAS. For more information about their setup (e.g. creation of account, station ID and key), please refer to the HELP menu on ProWeatherLive.net.

8. MAINTENANCE

8.1 FIRMWARE UPDATE

The console supports OTA firmware update capability. Its firmware may be updated over the air anytime (whenever necessary) through any web-browser on a PC/Mac with WI-FI connectivity. Update function, however, is not available through mobile/smart devices.

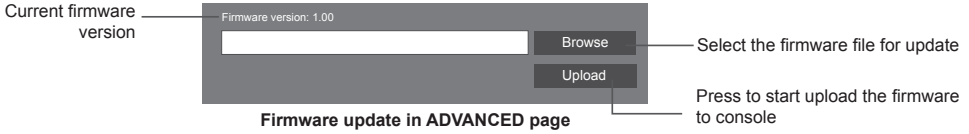

8.1.1 FIRMWARE UPDATE STEP

1. Download the latest version firmware to your PC/Mac.
2. Set the console into AP (access point) mode then connect the PC/Mac to the console (refer to **section 6.1** and **6.2**).
3. From the SETUP page, press ADVANCED to enter advance setting
4. Under the firmware upload section, press **Browse** to locate the firmware file saved on your PC/Mac.
5. Press **Upload** to start firmware update.

The update time is around 5 ~ 10 minutes. While updating, the progress will be displayed (i.e. 100 is completion).





6. The console will restart once the update is completed.
7. The console will stay in **AP mode** for you to check the firmware version and all the current setting. Simply press and hold [**SENSOR / WI-FI**] key for 6 seconds to exit AP mode.

IMPORTANT NOTE:

- Please keep connecting the power during the firmware update process.
- Please make sure your PC/Mac's WI-FI connection is stable.
- When the update process start, do not operate the PC/Mac and console until the update finished.
- During firmware update the console will stop upload data to the cloud server. It will reconnect to your WI-FI router and upload the data again once the firmware update succeed. If the console cannot connect to your router, please enter the SETUP page to setup again.
- After the firmware update, If the setup informations are missing, please input the setup information again.
- Firmware update process have potential risk, which cannot guarantee 100% success. If the update fail, please redo the above step to update again.

8.2 BATTERY REPLACEMENT

When low battery indicator  or  is displayed near the antenna icon of the sensor(s), it indicates that the outdoor 7-IN-1 sensor and/or current channel sensor(s) battery power is low respectively. Please replace with new batteries.

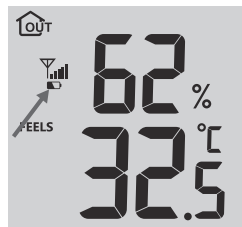

8.2.1 RE-PAIRING THE SENSOR(S) MANUALLY

Whenever you changed the batteries of the 7-in-1 weather sensor array or other additional sensors, re-synchronization must be done manually.

1. Change all the batteries to new ones in the low battery sensor(s).
2. Press [**SENSOR / WI-FI**] key on the console to enter sensor synchronization mode (as indicated by the flashing antenna Υ).

8.3 RESET AND FACTORY RESET

To reset the console and start again, press the [**RESET**] key once or remove the backup battery and then unplug the adapter.

To resume factory settings and remove all data, press and hold the [**RESET**] key for 6 seconds.

8.4 WIRELESS 7-IN-1 SENSOR ARRAY MAINTENANCE

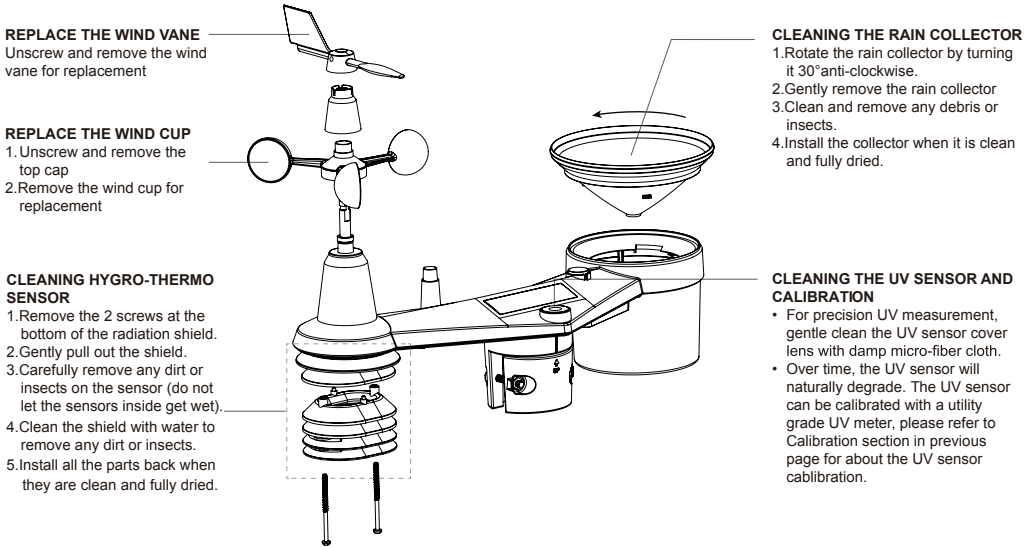

9. TROUBLESHOOT

Problems	Solution
7-in-1 wireless sensor is intermittent or no connection	<ol style="list-style-type: none">1. Make sure the sensor is within the transmission range2. If it still does not work, reset the sensor and resynchronize with console
Additional wireless sensor(s) is/are intermittent or no connection	<ol style="list-style-type: none">1. Make sure the sensor(s) is/are within the transmission range2. Make sure the channel displayed match to the channel selection on sensor3. If it still does not work, reset the sensor and resynchronize with console
No WI-FI connection	<ol style="list-style-type: none">1. Check the WI-FI icon on the display, it should be on if connectivity is successful2. In the console SETUP page, make sure the WI-FI settings (router's name, security type, password) are correct3. Make sure you connect to 2.4G band of the WI-FI router (5G not supported)
Data not reporting to ProWeatherLive	<ol style="list-style-type: none">1. In the console SETUP page, ensure your Station ID and Station Key are correct2. In the "Edit Devices" of the console on PWL, ensure the Device Mac address is entered correctly

Multi-day forecast, cloud cover, visibility, sunrise/sunset, moon rise/moon set times are not accurate	<ol style="list-style-type: none"> 1. Ensure your console is connected to PWL 2. Ensure latitude, longitude & time zone in "Edit Devices" of the console on PWL are correct 3. Press the [REFRESH] key to update the data instantly
Sunrise/sunset, moon rise/moon set times are different to that of PWL	<ol style="list-style-type: none"> 1. Ensure your console is connected to PWL 2. Ensure the console Time Sync is set to ON
Rainfall is not correct	<ol style="list-style-type: none"> 1. Make sure the rain collector is clean for the tipping bucket to tip smoothly 2. Make sure the sensor has stable and level mounting to ensure correct tipping
Problems	Solution
Temperature reading too high in the day time	<ol style="list-style-type: none"> 1. Place the sensor in open area and at least 1.5m off the ground. 2. Ensure that the sensor is placed away from heat generating sources or structures, such as buildings, pavement, walls or air conditioning units.
Some condensation beneath the UV sensor may occur overnight	This will disappear when temperature rises up under the sun and will not affect the performance of the unit.

10. SPECIFICATIONS

10.1 CONSOLE

General Specification	
Dimensions (W x H x D)	215 x 176.5 x 27mm (8.5 x 6.9 x 1.1 in)
Weight	503g (with battery)
Main power	DC 5V, 1A adapter (Manufacturer: HUAXU Electronics Factory, Model: HX075-0501000-AB)
Backup battery	CR2032
Operating temperature range	-5°C ~ 50°C
WI-FI Communication Specification	
Standard	802.11 b/g/n
Operating frequency :	2.4GHz
Supported router security type	WPA/WPA2, WPA3, OPEN, WEP (WEP only support Hexadecimal password)
Supported device for setup UI	Built-in WI-FI with AP mode function smart devices or laptops e.g.: Android smart phone, Android pad, iPhone, iPad or PC/ Mac computer.
Recommended web browser for setup UI	Web browsers that support HTML 5, such as the latest version of Chrome, Safari, Edge, Firefox or Opera.
Online Platform	
Website	https://proweatherlive.net
App name	ProWeatherLive
App platform	Google play and Apple Store
Wireless Sensor side Communication Specification	
Support sensors	<ul style="list-style-type: none"> - 1 Wireless 7-IN-1 weather outdoor sensor - Up to 7 Wireless hydro-thermo sensors / soil moisture sensor / pool sensor (optional) - Up to 7 Wireless water leak sensors (optional) - Up to 4 Wireless PM2.5 / 10 sensors (optional) - 1 Wireless Lightning sensor (optional)

RF frequency (Depend on country version)	868Mhz
RF transmission range	150m
Time Related Function Specification	
Time display	HH: MM
Hour format	12hr AM / PM or 24 hr
Date display	DD / MM or MM / DD
Time synchronize method	Through PWL to get the local time of the console location
Weekday languages	EN / DE / FR / ES / IT / NL / RU
Barometer (Note: Data detected by console)	
Barometer unit	hPa, inHg and mmHg
Measuring range	540 ~ 1100hPa
Accuracy	(700 ~ 1100hPa ± 5hPa) / (540 ~ 696hPa ± 8hPa) (20.67 ~ 32.48inHg ± 0.15inHg) / (15.95 ~ 20.55inHg ± 0.24inHg) (525 ~ 825mmHg ± 3.8mmHg) / (405 ~ 522mmHg ± 6mmHg) Typical at 25°C (77°F)
Resolution	1hPa / 0.01inHg / 0.1mmHg
Memory modes	Historical data of past 24 hours, daily Max / Min
Indoor Temperature (Note: Data detected by console)	
Temperature unit	°C and °F
Accuracy	<0°C or >40°C ± 2°C (<32°F or >104°F ± 3.6°F) 0~40°C ±1°C (32~104°F ± 1.8°F)
Resolution	°C / °F (1 decimal place)
Indoor Humidity (Note: Data detected by console)	
Humidity unit	%
Accuracy	1 ~ 20% RH ± 6.5% RH @ 25°C (77°F) 21 ~ 80% RH ± 3.5% RH @ 25°C (77°F) 81 ~ 99% RH ± 6.5% RH @ 25°C (77°F)
Resolution	1%
Memory modes	Historical data of past 24 hours, Max / Min
Outdoor Temperature (Note: Data detected by 7-in-1 sensor)	
Temperature unit	°C and °F
Weather index mode	Feels like, Wind Chill, Heat Index and Dew point
Feels like display range	-65 ~ 50°C
Dew point display range	-20 ~ 80°C
Heat index display range	26 ~ 50°C
Wind chill display range	-65 ~ 18°C (wind speed >4.8km/h)
Accuracy	5.1 ~ 60°C ± 0.4°C (41.2 ~ 140°F ± 0.7°F) -19.9 ~ 5°C ± 1°C (-3.8 ~ 41°F ± 1.8°F) -40 ~ -20°C ± 1.5°C (-40 ~ -4°F ± 2.7°F)
Resolution	°C / °F (1 decimal place)
Outdoor Humidity (Note: Data detected by 7-in-1 sensor)	
Humidity unit	%
Accuracy	1 ~ 20% RH ± 6.5% RH @ 25°C (77°F) 21 ~ 80% RH ± 3.5% RH @ 25°C (77°F) 81 ~ 99% RH ± 6.5% RH @ 25°C (77°F)
Resolution	1%

Wind Speed & Direction (Note: Data detected by 7-in-1 sensor)

Wind speed unit	mph, m/s, km/h and knots
Wind speed display range	0 ~ 112mph, 50m/s, 180km/h, 97knots
Resolution	mph, m/s, km/h and knots (1 decimal place)
Speed accuracy	< 5m/s: +/- 0.5m/s; > 5m/s: +/- 6% (whichever is greater)
Display mode	Gust / Average
Wind direction display mode	16 directions or 360 degree

Rain (Note: Data detected by 7-in-1 sensor)

Unit for rainfall	mm and in
Unit for rain rate	mm/h and in/h
Accuracy	± 7% or 1 tip
Range	0 ~ 19999mm (0 ~ 787.3 in)
Resolution	0.254mm (3 decimal place in mm)
Rain display mode	Rate / Hourly / Daily / Weekly / Monthly / Total rainfall

UV index (Note: Data detected by 7-in-1 sensor)

Display range	0 ~ 16
Resolution	1 decimal place

LIGHT INTENSITY (Note: Data detected by 7-in-1 sensor)

Light intensity unit	Klux, Kfc and W/m ²
Display range	0 ~ 200Klux
Resolution	Klux, Kfc and W/m ² (2 decimal place)

10.2 WIRELESS 7-IN-1 SENSOR

Dimensions (W x H x D)	390 x 217 x 165 mm (15.5 x 8.5 x 6.5in)
Weight	757g (with Batteries)
Main power	3 x AA size 1.5V batteries (Lithium batteries recommended)
Weather data	Temperature, Humidity, Wind speed, Wind direction, Rainfall, UV and light intensity
RF transmission range	150m
RF frequency (depend on country version)	868Mhz
Transmission interval	- 12 seconds for UV, light intensity, wind speed and wind direction data - 24 seconds for temperature, humidity and rain data
Operating temperature range	-40 ~ 60°C (-40 ~ 140°F)
Operating humidity range	1 ~99% RH non-condensing

UKCA Declaration of Conformity

UK CA Youshiko Ltd hereby declares that the product fully complied to applicable guidelines and corresponding standards for sales in the UK. For full details, please contact customer services of Youshiko Ltd (email address : cs@youshiko.co.uk).

All enquiries: service@youshiko.co.uk
Made for Youshiko in PRC



