

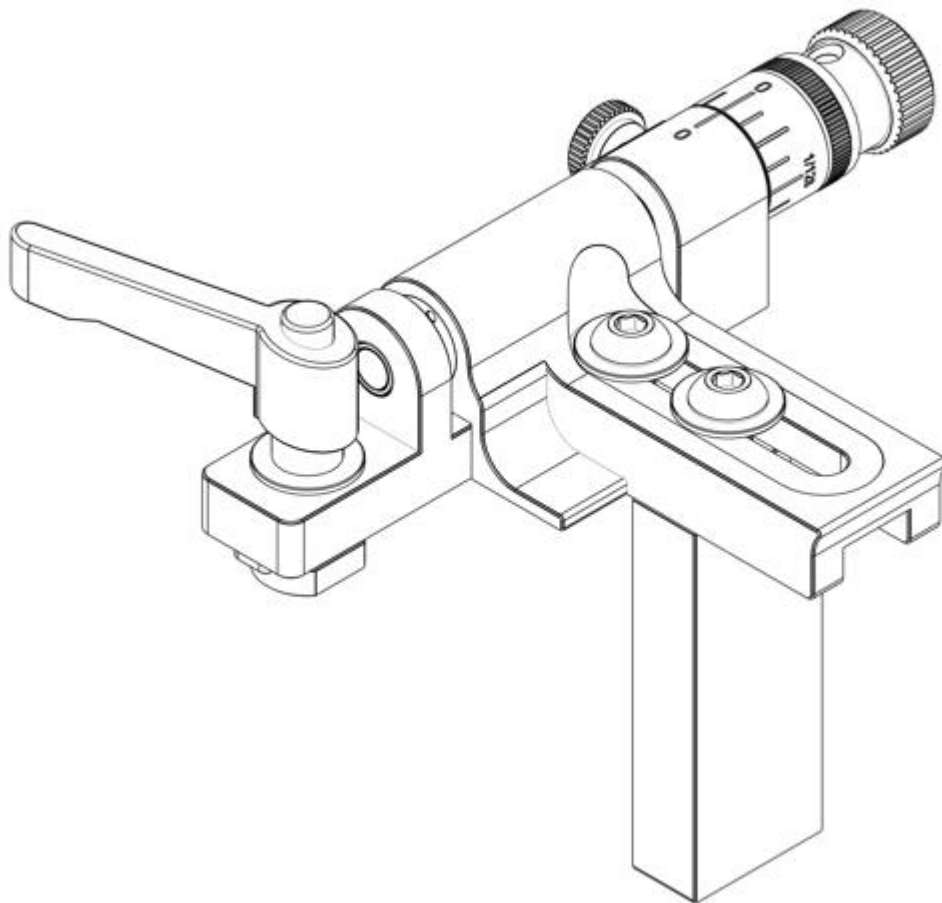

# Miter Gauge Micro Adjuster



**Model #07151**

**TO REDUCE THE RISK OF INJURY, USER MUST READ OPERATORS  
MANUAL**

# THANK YOU FOR CHOOSING



Thank you for choosing this product from JessEm Tool Company. We appreciate your support and hope that our product serves you well. This product is designed to provide many years of reliable service provided it is used as intended and taken care of.

This user manual will assist you in assembly and general operation of this product. It is not our intent to teach you about woodworking. It is assumed that you are an experienced woodworker with the basic skills and experience necessary to use this product safely. If after reading the following instructions you are unsure or uncomfortable about safely using this product, we urge you to seek additional information through widely available woodworking books or classes.

As part of our Continuous Product Improvement Policy, JessEm products are always advancing in design and function. Therefore, there may be differences between what is shown in our catalogs, website or at retail display and what is sold at time of purchase. We reserve the right to make positive changes to our products at our discretion.

If you have any questions about our products or service, please call us at **1-800-436-6799** or email us at **[customerservice@jessem.com](mailto:customerservice@jessem.com)**

## Find us on social media



[youtube.com/JessEmToolCompany](https://www.youtube.com/JessEmToolCompany)



[facebook.com/JessEmTools](https://www.facebook.com/JessEmTools)



[instagram.com/jessemtoolcompany](https://www.instagram.com/jessemtoolcompany)

324 Desbrisay Avenue  
Moncton, New Brunswick,  
E1E 0G8, Canada

Toll Free: 800-436-6799  
Local Phone: 705-726-8233  
Fax: 705-327-0295  
Website: [www.JessEm.com](http://www.JessEm.com)

## WHATS IN THE BOX

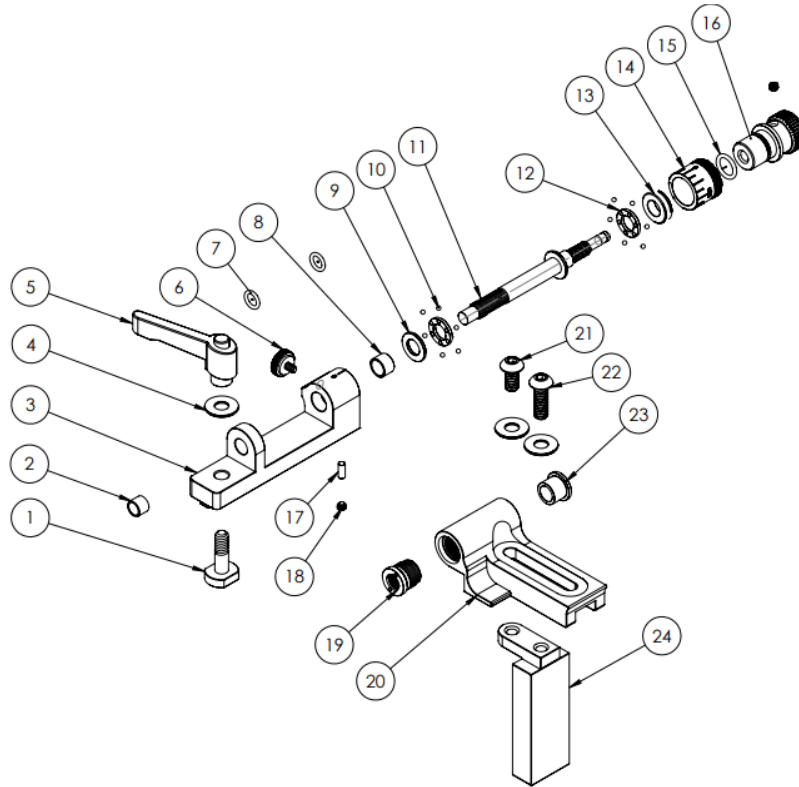

Item #	Description	QTY.
1	T-Bolt	1
2	5/16" O.D. x 1/4" ID x 1/4" Long Bushing	1
3	Fence Mount	1
4	1/4" S.S. Small OD Washer	3
5	Plastic Adjustable Knob	1
6	Adjustment Lock Knob	1
7	010 O-ring	2
8	3/8" O.D. x 5/16" ID x 1/4" Long Bushing	1
9	M8 S.S. Small OD Washer	2
10	5/64" Hardened steel Ball	12
11	Adjusted Spindle	1
12	Thrust Bearing Retainer	2
13	Adjustment Screw	1
14	Adjustment Sleeve	1
15	014 O-ring	1
16	Adjustment Knob	1
17	1/8" x 0.25" Acetal Dowel Pin	1
18	8-32 x 3/16" S.S. Cup Point Set Screw	2
19	Adjustment Nut	1
20	Upper Flip Stop	1
21	1/4"-20 x 1/2" S.S. BHCS	1
22	1/4"-20 x 3/4" S.S. BHCS	1
23	7/16" O.D. x 5/16" ID x 3/8" Long Flanged	1
24	Lower Flip Stop Bushing	1

## WARRANTY

### JESSEM TOOL LIMITED WARRANTY

All JessEm products are warranted to be free from defects in material and workmanship. JessEm will repair or replace any product which upon inspection proves to be defective for a period of (1) year from dated receipt and proof of purchase. All warranty claims should be made direct to JessEm Tool Company.

Contact JessEm for a warranty claim return authorization and instructions to proceed. The consumer is responsible for shipping costs to return product to JessEm Tool Company. We will repair or replace the product at our discretion and JessEm Tool will return shipment to you at no charge.

### WARRANTY LIMITATIONS

This warranty does not cover:

- Repairs or alterations made or attempted by anyone other than JessEm Tool Company or an authorized JessEm service professional.
  - Normal wear and tear
  - Abuse, misuse or neglect.
  - Improper care or maintenance.
  - Continued use after partial failure.
  - Products that have been modified in any way.
  - Products used with improper accessories

DATE PURCHASED: \_\_\_\_\_

WHERE PURCHASED: \_\_\_\_\_

ADDRESS: \_\_\_\_\_

## IMPORTANT SAFETY PRECAUTIONS

- Before operating any power tools, read and understand all safety instructions in the owner's manual that came with them.
- If you do not have a manual, contact the manufacturer and obtain one before using any power tool.
- Always wear eye protection in compliance with ANSI safety standards when operating any power tool.
- Do not wear loose clothing or jewellery that may catch on the tools or equipment.
- Unplug the tool or machine when making any adjustments.

 **WARNING:** To reduce the risk of injury, always unplug your tool before performing any maintenance. Never disassemble the tool or try to do any rewiring on the tool's electrical system.

 **WARNING:** Read and understand all instructions before using. Failure to follow all instructions listed above or to use the micro adjuster in a safe manor may result in serious personal injury.

 **WARNING:** This product can expose you to chemicals including lead and/or chromium, known to the State of California to cause cancer and birth defects or other reproductive harm.

 **WARNING:** Drilling, sawing, sanding or machining wood products can expose you to wood dust, a substance known to the state of California to cause cancer. Avoid inhaling wood dust or use a dust mask or other safeguards for personal protection.

## TOOLS REQUIRED

- 5/32" hex key (included)

## Attaching Micro Adjuster to Fence

1. With the plastic adjustable knob loosened, slide the T-bolt into the T-Track on the top of your Miter Gauge. Ensure the micro adjuster is oriented so the flip stop will lay down onto the face that will be used to push the workpiece (see figure 1).
2. Slide the micro adjuster to the desired position and tighten the plastic adjustable knob to lock it onto the fence.
3. With the flip stop in the downward position, slide the lower stop into the upper stop until it is aligned with the fence. Using a 5/32" Hex Key, insert the two screws with washers and tighten until the lower stop is firmly attached to the rest of the body
4. Your Micro Adjuster is now set for your miter gauge and ready to be used.

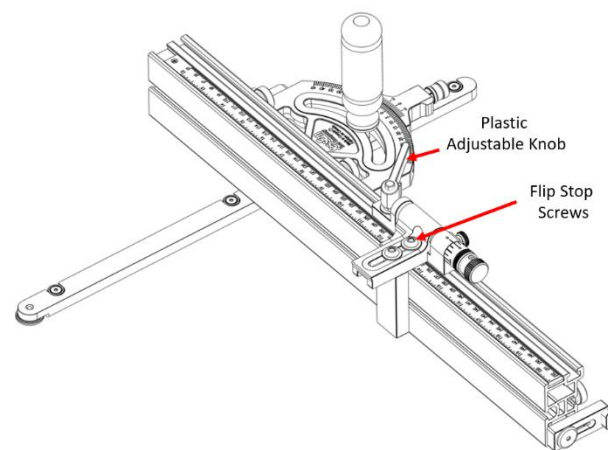

*Figure 1*  
pictured with Mite-R-Excel II (Not Included)

## HOW TO USE

1. Loosen the adjustment lock knob and turn the adjustment knob until the stop is located roughly in the middle of its range of motion. Retighten the adjustment lock knob and turn the adjustment sleeve until it is zeroed in its current position. This will allow you to adjust the stop in either direction if required.
2. Loosen the plastic adjustable handle and slide the Micro Adjuster until the right-hand side of the upper flip stop is aligned with the desired cut length.
3. Using a scrap piece of wood, make a cut and check the length. If the length is off, loosen the adjustment lock knob and turn the adjustment knob to change the length. Use the scale on the adjustment sleeve to adjust by the correct amount. Turning the adjustment knob clockwise will lengthen the cut while counter clockwise will shorten it. Ensure the adjustment lock knob is retightened before making another cut.
4. When not in use, simply flip the stop out of the way to use the miter gauge without obstruction.

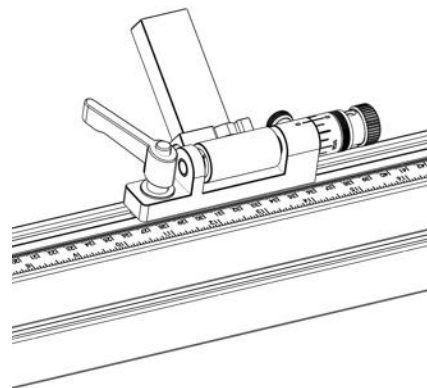
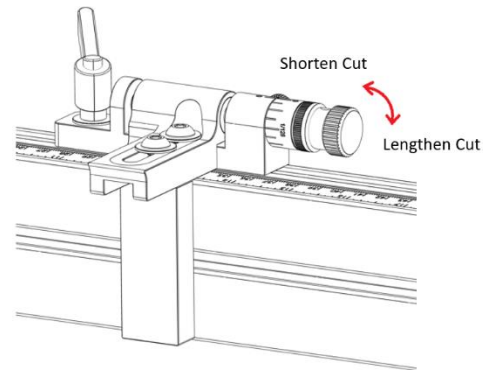
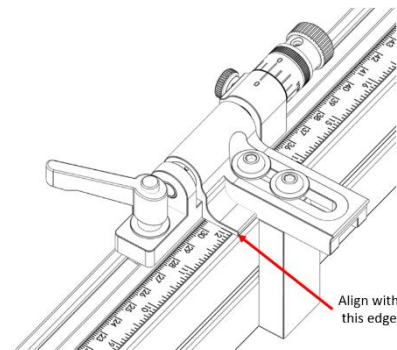
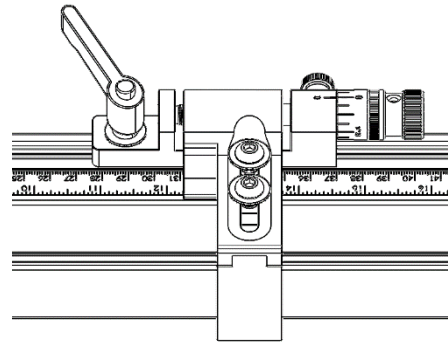

**Note:** this product has been designed to be used with the JessEm Mite-R-Excel II.