



Operating Instructions and Parts Manual

Mast-R-Fence and Rout-R-Fence

Models: 04010 and 04100



JessEm Tool Company

61 Forest Plain Road

Oro-Medonte, Ontario, Canada

L3V 0R4

Local: 705-726-8233

Fax: 705-327-0295

Toll Free: 1-866-272-7492 Website:

www.jessem.com Email:

jessem@jessem.com

Thank you for choosing this product from JessEm Tool Company. We appreciate your support and hope that our product serves you well. This product is designed to provide many years of reliable service provided it is used as intended and taken care of.

This user manual will assist you in assembly and general operation of this product. It is not our intent to teach you about woodworking. It is assumed that you are an experienced woodworker with the basic skills and experience necessary to use this product safely. If after reading the following instructions, if you are unsure or uncomfortable about safely using this product we urge you to seek additional information through widely available woodworking books or classes.

As part of our Continuous Product Improvement Policy, JessEm products are always advancing in design and function. Therefore there may be differences between what is shown in our catalogs, website or at retail display and what is sold at time of purchase. We reserve the right to make positive changes to our products at our discretion.

JessEm Tool Company Warranty

All JessEm products are warranted to be free from defects in material and workmanship. JessEm will repair or replace any product which upon inspection proves to be defective for a period of (1) year from dated receipt and proof of purchase. All warranty claims should be made direct to JessEm Tool Company. Contact JessEm for a warranty claim return authorization and instructions to proceed. The consumer is responsible for shipping costs to return product to JessEm Tool Company. We will repair or replace the product at our discretion and JessEm Tool will return shipment to you at no charge.

Warranty Limitations

This warranty does not cover:

- Repairs or alterations made or attempted by anyone other than JessEm Tool Company or an authorized JessEm service professional.
- Normal wear and tear
- Abuse, misuse or neglect.
- Improper care or maintenance.
- Continued use after partial failure.
- Products that have been modified in any way.
- Products used with improper accessories.
- Premature thread-wear due to adjusting height with electric or cordless drill.

Important Safety Precautions

- Before operating any machinery or power tool, read and understand all safety instructions in the owner's manual for the tool or machine.
- If you do not have a manual, contact the manufacturer and obtain one before using any tool or machine.
- Always wear eye protection in compliance with ANSI safety standards when operating any power tools or machinery.
- Always use proper guards and safety devices when operating power tools and machinery.
- Carefully check router bits before each use. Do not use if damage or defect is suspected.
- Do not exceed the recommended RPM for any router bit.
- Do not wear loose clothing or jewelry that may catch on tools, machinery or equipment.
- Unplug the tool or machine when mounting or making any adjustments to mechanical performance.

Routing Safety Precautions

- **Always make sure the fence on your router table is locked firmly into position before each use.**
- Never force the bit or overload the router beyond the expectations of the tool.
- Be sure that at least 3/4 of the shank length is inserted securely in the router collet.
- Never bottom out the bit in the collet. Allow 1/8" clearance between bottom of shank and bottom of collet.
- Always rout in two or more passes when large amounts of stock must be removed.
- Use reduced RPM speeds for larger diameter router bits.

Suggested Router Bit Speeds

<u>Bit Diameter</u>	<u>Max. Speed</u>
1" (25mm)	24,000 RPM
1-1/4" - 2" (30-50mm)	18,000 RPM
2-1/4" - 2-1/2" (55-65mm)	16,000 RPM
3" - 3-1/2" (75-90mm)	12,000 RPM

CALIFORNIA PROPOSITION 65 WARNING

This product contains lead known to the State of California to cause cancer or reproductive harm. Components made of brass are known to contain lead. Wash hands after using this product.

Tools Required for Assembly

- Phillips screw driver
- 10 mm wrench or socket
- 3/16" Drill Bit*
- 1/16" Drill Bit*

*Note: This is required if you are not mounting to a JessEm table top.

Assembling the Fence Tracks

There are two different types of fence tracks depending upon which model fence you have purchased.

Fence model 04010 (Master Fence) has a table mounting bracket provided with a T-nut slot for mounting the fence to the bracket (Fig 1). When assembling the table mounting bracket to the fence track use a 6mm hex bolt with a flat washer and insert the bolt into the lower slots on the fence track. Screw the T-nuts onto the bolts. Slide the T-nuts into the T-slot on the table mounting bracket. Do not tighten this assembly at this stage.

Fence model 04100 (Router Fence) has a table mounting bracket but does not have the T-slot in the bracket as Model 04010. Mount the table bracket directly to the fence track using 6mm hex bolts and flat washers (Fig. 2). Do not tighten this assembly at this stage.

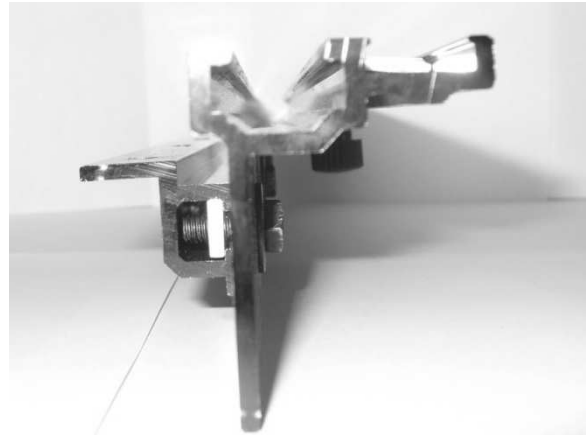

Figure 1

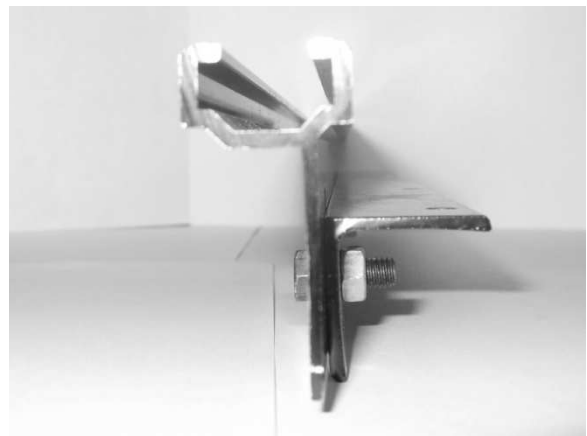

Figure 2

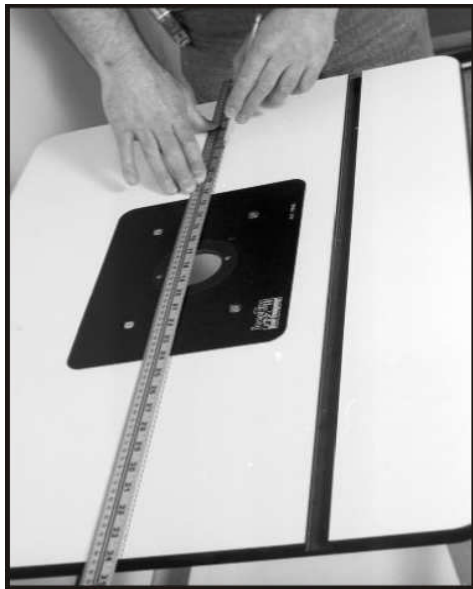

Figure 3

Mounting the Fence Tracks to the Table

Note: If you are mounting the fence to a JessEm table top proceed to the next page section “For JessEm table”.

Measure the distance from the front edge of your table to the center of the bit hole in the table top. Transfer a mark the same distanced on both the left and right edges of the table top. Then draw a



Figure 4

From the center line you drew, come three inches toward the front of the table and mark a small line on both the left and right sides of the table (Fig. 4).



Figure 5

Take one of the fence track assemblies and line it up with the mark you made in figure 4. Make a mark on the underside of the table top to locate the same position on the bottom of the table (Fig. 5).



Figure 6

Flip the table top over and position the fence bracket upside down and line up the front edge with the mark you made in step 5. Using a pencil or a 3/16” diameter drill bit mark the 4 holes for mounting the fence bracket. Pre-drill the holes using a 1/16” diameter drill bit and be sure you don’t drill through the table top surface (Fig. 6). Using the #6 x 3/4” wood screws secure the fence track assembly to the table. Repeat all steps for the second fence bracket.

For JessEm Table Top

If you are mounting the fence to a JessEm table top the top is already pre-drilled for the fence mounting angle brackets. With the table upside down position the left and right fence track assemblies and attach to the table with the 6mm x45mm socket head cap screws for phenolic tables and 4.8mm x 25mm wood screws for MDF tables and proceed to the next step.



Figure 7

Leveling the Fence Track

Place the fence on the table top in its upright position and allow it to hang over the table edge and lie across the front end of the fence track. Raise the fence track assembly so that it is positioned flush to the bottom of the fence as it rests on the table top. With a 10mm wrench or socket tighten the front bolt of the fence assembly (Fig. 7).

Move the fence back and use it to position the rear end of the bracket in the same way and tighten the rear bolt. Then tighten the center bolt to complete the leveling of the fence track. Repeat this process for the fence track on the other side of the table.

When tightening the fence track mounting bolt on Model 04010, the T-nut will tighten in the T-track and hold the fence track securely. When tightening the fence track mounting bolt on Model 04100 you will need a 10mm wrench to hold the hex nut while tightening the hex bolt securely.

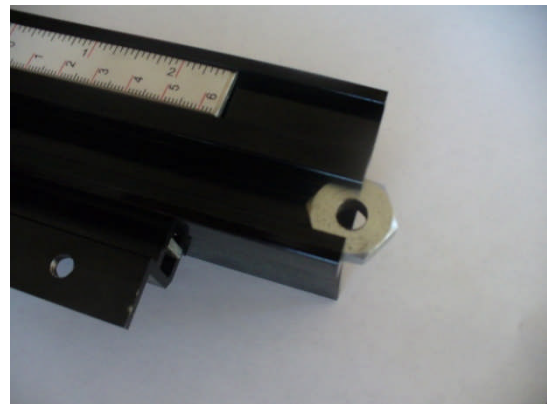

Figure 8

Mounting the Fence to the Tracks

Slide the $\frac{3}{4}$ " hex T-nut for the extension knob into the T-slot next to the scales on the fence track (Fig. 8). The extension knobs will thread into these nuts to hold the fence in position. To do so, position the end of the fence over the track and look directly down through the open slot in the base of the fence frame and visually line up the hole in the rectangular T-nut.

Then insert the threaded tip of the extension knob through the slot fence and into the threaded hole in the T- nut (Fig. 9). Twisting the lock-down knob clockwise will fasten the fence to the tracks and hold the fence firmly in position.

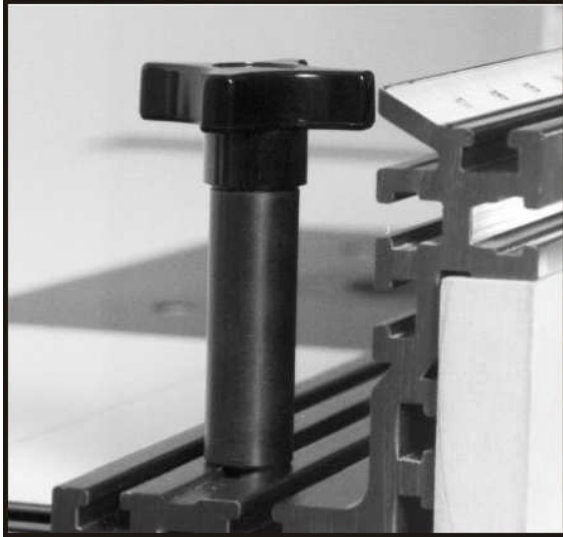

Figure 9

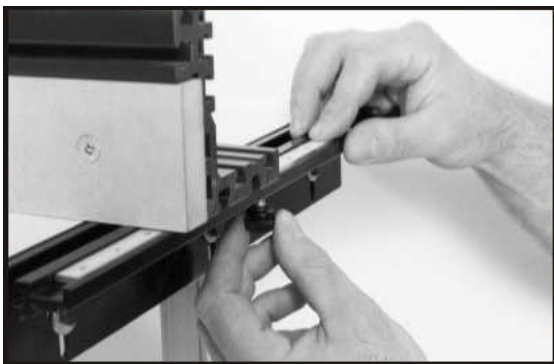

Figure 10

Adjusting the Fence Track Scales

The scales on the fence tracks are adjustable for added versatility in positioning the fence. To adjust the scales loosen the knurled nut underneath the fence track adjust the scale and re-tighten the nut (Fig. 10). You can use the scales as a zero reference point by adjusting the scales to “0” once your fence is set up in your desired position relevant to the router bit you are using. Please note that fence scales are only available on Model 04010. Fence scales are not available for Model 04100.

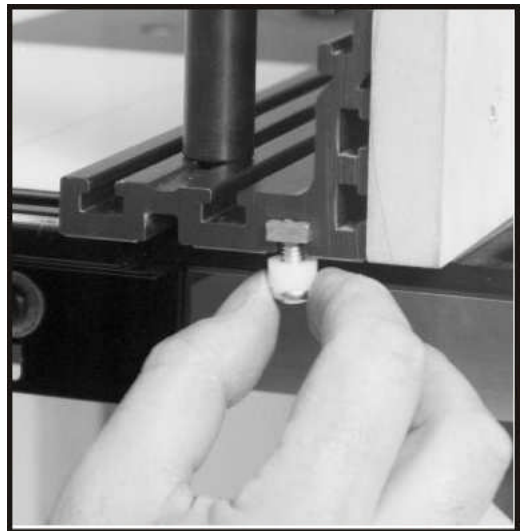

Figure 11

Centering the Fence to the Table

The Mast-R-Fence offers a unique means of keeping the fence centered on the table with a nylon bushing. Take the 6mm x 15mm bolt and insert into the 1/2" nylon spacer and thread on one of the square 6mm nuts. Do not thread the square nut on all the way. Slide the square nut into the front T-slot under the left end of the fence (Fig. 11). Leave the assembly loose and approximately 1" in from the end of the fence.

Note: Fence Model 04100 does not come with the nylon bushing for centering. Model 04010 is the only fence equipped with this feature.

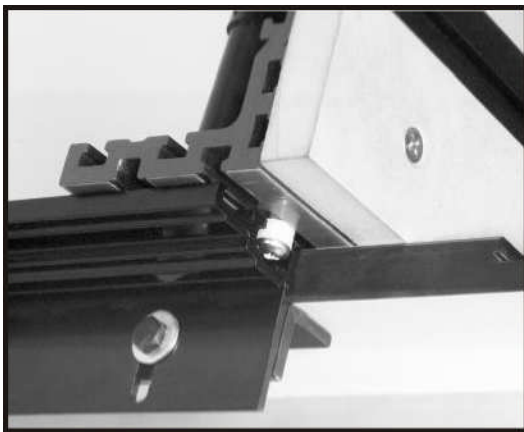

Figure 12

Slide the fence with the nylon spacer attached into the T-slot on the left fence track (Fig. 12). The nylon spacer should be slightly loose to allow for some movement.

Now slide the fence back and center the fence left to right with the center of the bit opening. Make sure it is parallel with the front edge of the table or miter track.

Now slide the fence, keeping it square (use the scales on the fence track to ensure you are square) to the front of the table, just until the nylon spacer comes out of the track. Then tighten the bolt on the spacer being very careful not to change its position (Fig. 13).

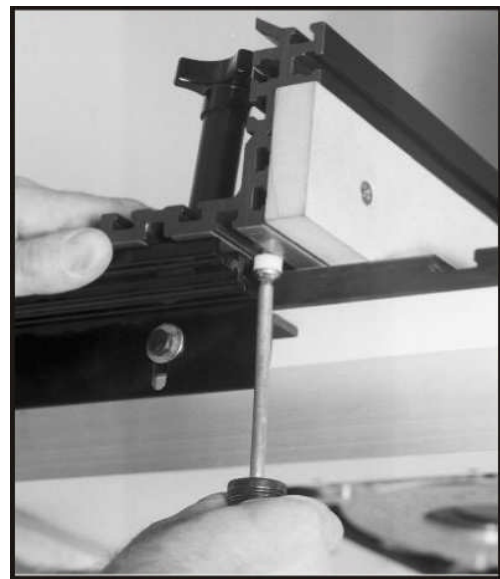

Figure 13

Slide the fence back to the center of the table. Re-check to see if the fence is centered on the table. If not repeat until you achieve your desired result.

Installing the Sub-Fences

Locate the sub-fences in the packaging. Place the sub-fence against the front of the fence extrusion (Fig. 14). Align the holes in the sub-fence with the slots in the fence extrusion. Insert the 6mm x 45mm screws through the hole in the front of the sub-fences (Fig. 15).

Place the 6mm washer over the sub-fence bolt. Screw the black knob onto the sub-fence bolt (Fig. 16).

Repeat these steps for the remaining two holes. Repeat these for the other sub-fence.



Figure 14



Figure 15



Figure 16

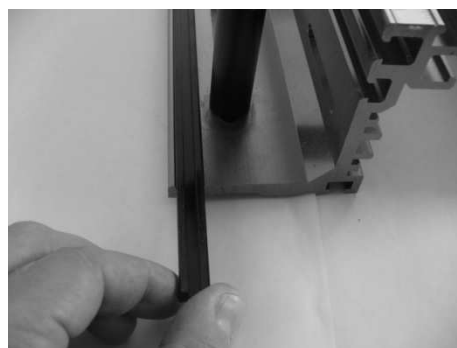

Figure 17

Installing Sub-Fence Offset Track

Fence Model 04010 and Model 04100 are both equipped with sub-fence offset tracks. These offset tracks are designed to be installed two allow for a 1/32" or 1/16" offset of the sub-fence. Notice the female profile of the extrusion, you will see that one side of the profile is deeper than the other side. The small side is 1/32" and the deeper side is 1/16".

The sub-fence offset tracks are located on the backside of the fence in a specially designed storage location (Fig. 17).

Remove one side of the fence sub-fences by unscrewing the black knob and removing the sub-fence bolts (Fig. 18). Once the sub-fence has been removed, notice the end of the fence extrusion. The fence extrusion is designed with mating male profiles designed to accept the offset tracks (Fig. 19). Slide the offset tracks onto the fence extrusion take care that you install both offsets on the same side (Fig. 20). Both offsets should always be installed on the same side to insure the sub-fence is offset the same distance at the top and bottom of the sub-fence. Once the offset tracks are securely in place, reinstall the sub-fence with the sub-fence bolt, washer, and black locking knob.



Figure 18

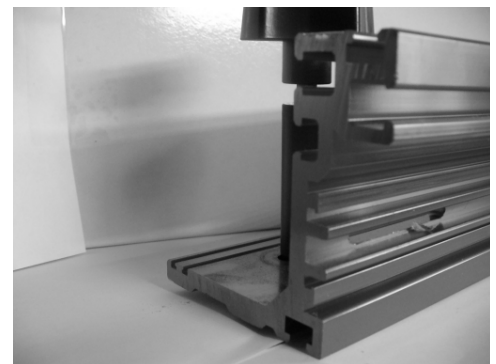

Figure 19

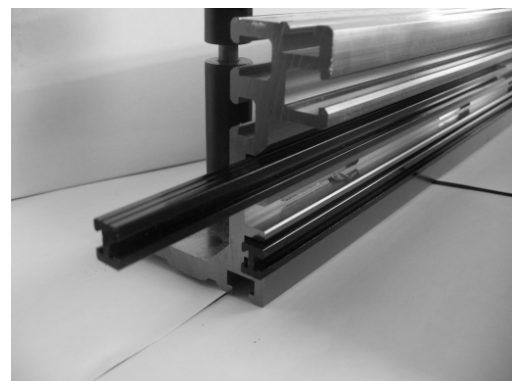

Figure 20

Attaching the Router Bit Guard

Take the clear polycarbonate guard and two of the black knurled knobs and two 1/4" square nuts. Insert each knob through each slot in the guard and thread a square nut onto each bolt end.

Line up the nut on the guard assembly and slide each nut into the T-slot starting from the end of the fence (Fig. 21). Then slide the guard to the center of the fence and adjust the guard slightly higher than and above the router bit. Be sure the guard clears the bit. Adjust and tighten securely before each use and after all bit changes.

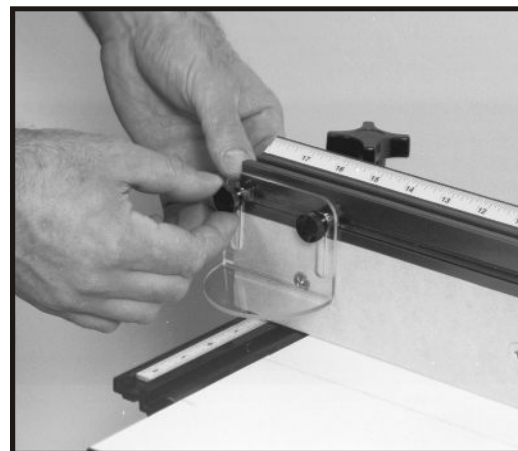

Figure 21

JesseM
Tool Company

Tools That Make A Difference!

04100 Rout-R-Fence Parts List

Item No.	Part No.	Description	Qty	Part Specification
1	04100-001	Fence Track Mtg Angle Wood Screw	8	4.8MX25M
2	04100-002	Fence Track Mtg Nut	6	M6
3	04100-003	Fence Track Mtg Angle	2	
4	04100-004	Fence Miter Track	2	
5	04100-005	Fence Track Mtg Washer	6	6.5MX14.5MX1.2M
6	04100-006	Fence Track Mtg Bolt	6	M6X16
7	04100-007	Fence Face Mtg Bolt	6	M6X45
8	04100-008	Fence Face	2	
9	04100-009	Fence Clamping Knob	2	
10	04100-010	Fence Clamping Nut	2	M8
11	04100-011	Knob Extension	2	
12	04100-012	Clamping Knob	6	
13	04100-013	Vacuum Port Mtg Screw	2	M6X20
14	04100-014	Vacuum Port/Dust Chute	1	
15	04100-015	Vacuum Port Square Nut	4	M6
16	04100-016	Fence Extrusion	1	
17	04100-017	Fence Shimmiing Bar	2	
18	04100-018	Fence Guard	1	
19	04100-019	Fence Guard Locking Knob	2	

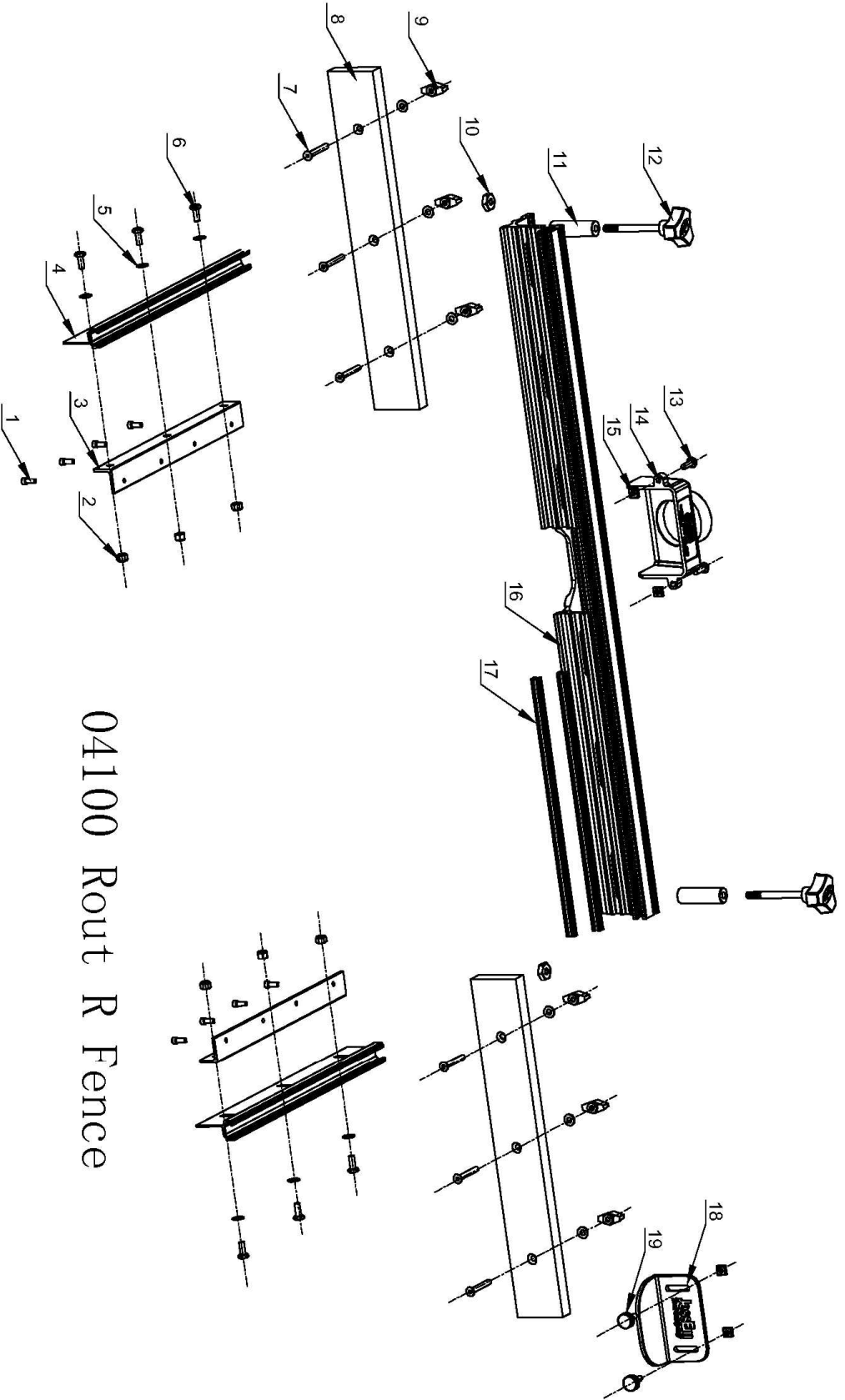

04100 Rout R Fence

04010 Mast-R-Fence II Parts List

Item No.	Part No.	Description	Qty	Specification
1	04010-001	Scale Mounting Bar and Scale	2	
2	04010-002	Fence Track	2	
3	04010-003	Fence Bracket Mtg Track Screw	8	M5X12
4	04010-004	Track Mounting Angle	2	
5	04010-005	Flat Washer	12	6.5X14.5X1.2
6	04010-006	Fence Track Scale Locking Knob	4	
7	04010-007	Fence Track Mtg bolt	6	M6X16
8	04100-010	Fence Clamping Nut	2	M8
9	04010-009	Centering bushing bolt	1	M6X15
10	04010-010	1/2" Nylon Spacer	1	
11	04100-007	Fence Face Bolt	6	M6X45
12	04010-012	Fence Face	2	
13	04100-012	Clamping Knob	6	
14	04100-015	Centering bushing nut	11	M6
15	04100-011	Knob Extension	2	
16	04100-009	Fence Clamping Knob	2	M8
17	04010-017	Fence Extrusion	1	
18	04100-013	Vacuum Port/Dust Chute Screw	2	M6X20
19	04100-014	Vacuum Port/Dust Chute	1	
20	04010-020	Fence Shimming Bar	2	
21	04100-018	Fence Guard	1	
	04100-015	Vacuum Port/Dust Chute nut	2	
	04010-023	Fence Scale	1	

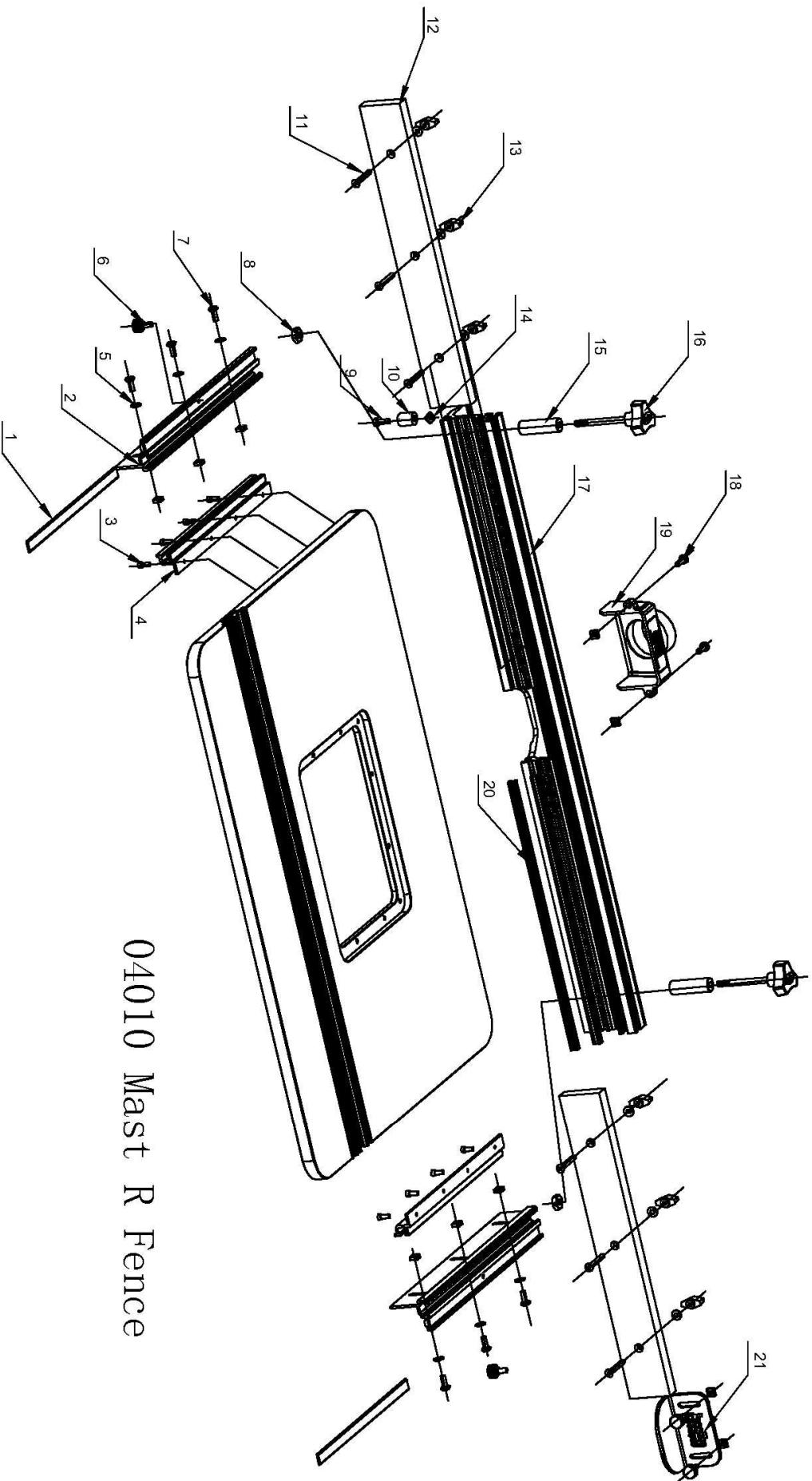

04010 Mast R Fence