



# THE REAL #1

ANYONE CAN CLAIM IT. WE PROVE IT!



FREAKSHOW  
**FULKRUM FLEX**

THE TEAM AT T.R.U. BALL® AND I, WORKED HARD ON DESIGNING THIS RELEASE FROM THE GROUND UP. USING SOME TECHNOLOGIES AND ADJUSTABILITY NEVER SEEN BEFORE IN A HAND HELD RELEASE. OUR GOAL WAS TO PROVIDE THE USER WITH A COMFORTABLE RELEASE AND ALLOW THE ADJUSTABILITY TO FIT YOUR INDIVIDUAL STYLE SO YOU CAN BE AS CONSISTENT, COMFORTABLE, AND ACCURATE AS POSSIBLE.



Chan Soon-Shiong  
Institute of Molecular Medicine  
at Windber

EVERY RELEASE SOLD A PERCENTAGE OF THE SALES WILL GO TO THE CHAN SOON-SHIONG INSTITUTE OF MOLECULAR MEDICINE AT WINDBER TO HELP FIGHT BREAST CANCER. THAT IS WHAT I AM MOST EXCITED ABOUT KNOWING THAT WE ARE HELPING SUPPORT A GOOD CAUSE. THAT MAKES ME FEEL GREAT.

**FULKRUM FLEX (TFLF-QS-M)**

Fulkrum Flex / QuickSilver / Medium

611254016602

follow us



*We Make Archery Better!*

[WWW.TRUBALL.COM](http://WWW.TRUBALL.COM)

⚠️ WARNING: This product can expose you to chemicals including Nickel Acetate, which is known to the State of California to cause cancer or birth defects or other reproductive harm. For more information, visit [www.P65Warnings.ca.gov](http://www.P65Warnings.ca.gov).

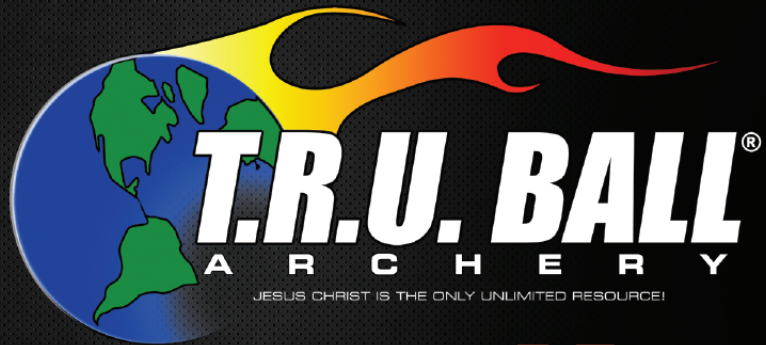

JESSE BROADWATER



SIGNATURE SERIES

FREAKSHOW  
**FULKRUM FLEX**



A MATCHING HANDLE TO THE ABYSS FLEX  
**MICRO-ADJUST BACK TENSION RELEASE**  
**HANDLE ADJUSTS FOR A PERFECT FIT**

**COMFORT FLEX TECHNOLOGY**



ADJUST HANDLE FOR A PERFECT FIT  
US PAT# 9,618,295 B1



**RADIAL 30° ADJUSTABLE FINGER PIECES**  
4 FINGER PIECES SOLD SEPARATELY



**QUICKSILVER FINISH OPTION**  
CORROSION RESISTANT ELECTROLESS BRUSHED NICKEL PLATED BRASS

30° OF RADIAL ROTATION  
(15° FORWARD AND 15° BACK)  
IN BOTH 3 AND 4 FINGER PIECES

MADE IN





**FREAKSHOW**  
**FULKRUM**  
**FLEX**

www.TRUBALL.com

**WARNING: PINKY SIDE OF HANDLE MUST BE ROTATED FORWARD WHEN DRAWING BOW - THIS IS A HINGE BACK TENSION RELEASE.**

**ADJUSTMENT INSTRUCTIONS:**

- TRAVEL SETTING ADJUSTMENT:** LOOSEN SPEED ADJUSTMENT LOCK SCREW(B). TURN SENSITIVITY ADJUSTMENT SCREW(A) TO DESIRED SPEED. USE THE POINTER AND LINES(C) TO REFERENCE SPEED SETTING. TIGHTEN SPEED ADJUSTMENT LOCK SCREW(B) REPLACE ONBOARD MICRO-ADJUSTMENT TOOL INTO SUPPLIED HOLE IN HANDLE
- LAS HEAD POSITION ADJUSTMENT:** USE A 5/64" ALLEN WRENCH TO REMOVE THE SOCKET HEAD CAP SCREWS(D) ALONG THE SIDE OF THE RELEASE TO RE-POSITION THE HEAD IN YOUR CHOICE OF FOUR DIFFERENT POSITIONS.  
**NOTE:** CHANGING HEAD POSITION MOVES BOWSTRING AWAY FROM FACE CONTACT FOR EXTREME ACCURACY. IT ALSO CHANGES SPEED IN WHICH THE RELEASE FUNCTIONS.  
**WARNING: BE SURE TO RESET TRAVEL SETTING IF ADJUSTING THE HEAD INTO A NEW POSITION.**
- FINGER PIECE PERFECT FIT ADJUSTMENT:** USE A 5/64" HEX WRENCH TO LOOSEN SCREW(E), FLEX HANDLE INTO DESIRED POSITION AND RETIGHTEN. **WARNING: DO NOT OVERTIGHTEN!**
- ADDING OR REMOVING FINGER PIECES:** USE A 5/64" HEX WRENCH TO REMOVE SCREW(E). NOTE: SMALL WASHER(F) IS CONTAINED IN INNER POCKET(G) BE CAREFUL NOT TO LOSE WASHER. INSTALL DESIRED FINGER PIECE/PIECES. INSURE SMALL WASHER(F) IS INSTALLED INTO THE CLOSED END OF INNER POCKET(G). PUSH FINGER PIECE ALL THE WAY INTO THE HANDLE. INSURE SCREW(E) PASSES THROUGH WASHER(F) AND RETIGHTEN. SEE FIGURE 2 FOR REFERENCE  
**WARNING: DO NOT OVERTIGHTEN!**
- TO CHANGE SEARS FROM CLICK TO NO CLICK:** SEE FOLLOWING PAGES FOR FULL INSTRUCTIONS. FIGURE 1

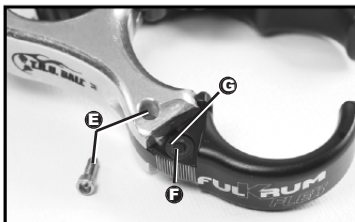
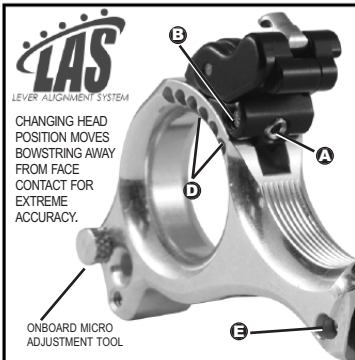
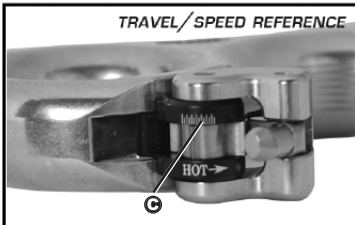
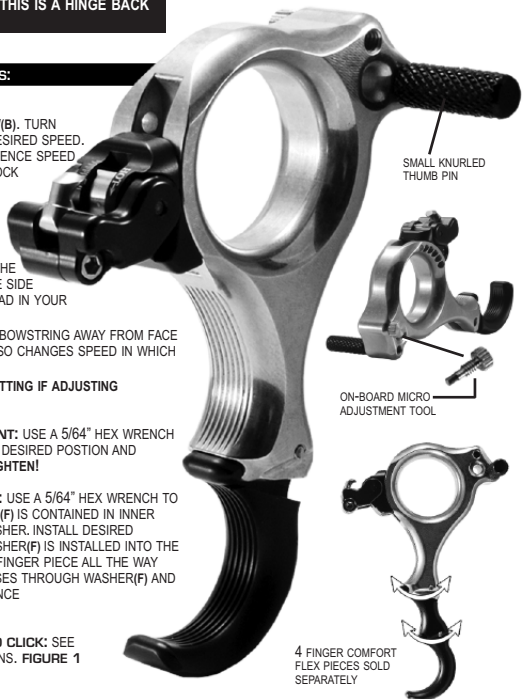

**WARNING :**

- \* NEVER DRAW BOW WITHOUT AN ARROW!
- \* ALWAYS POINT BOW AT A SAFE TARGET! NEVER POINT BOW IN AN UNSAFE DIRECTION!
- \* DO NOT LET GO OF THIS RELEASE DURING THE SHOT PROCESS!
- \* NEVER PULL THE RELEASE TOWARD FACE WHEN DRAWING BOW!
- \* INSPECT EQUIPMENT BEFORE USE TO INSURE PROPER OPERATING CONDITION!
- \* FAILURE TO FOLLOW THESE WARNINGS COULD RESULT IN EQUIPMENT DAMAGE OR INJURY!
- \* THINK AND ACT SAFELY!

**LIMITED WARRANTY**

THIS PRODUCT IS GUARANTEED AGAINST DEFECTS IN MATERIAL AND WORKMANSHIP NOT CAUSED BY NORMAL WEAR TO THE ORIGINAL OWNER, WITH A VALID SALES RECEIPT. THIS WARRANTY IS VOID IF THE RELEASE HAS BEEN DISASSEMBLED, ABUSED, MODIFIED, OR SUBJECT TO ABNORMAL CONDITIONS. WRIST STRAPS ARE NOT COVERED UNDER WARRANTY. WE RECOMMEND YEARLY STRAP REPLACEMENT.

**LETTING GO OF YOUR RELEASE AID AT ANY TIME DURING THE SHOT PROCESS, AS EVIDENCED BY ABNORMAL DENTS AND/OR BENT PARTS, WILL VOID THIS WARRANTY.**

T.R.U., INC. WILL NOT BE LIABLE FOR ANY CONSEQUENTIAL OR INCIDENTAL DAMAGES TO ANY OTHER PIECE OF EQUIPMENT THE RELEASE MAY COME IN CONTACT WITH. T.R.U., INC. WILL NOT BE LIABLE FOR ANY INJURIES OR DAMAGES TO ANY PERSON, PROPERTY OR EQUIPMENT THAT IS CAUSED BY THE IMPROPER USE OF THIS PRODUCT.

IF YOU EXPERIENCE ANY PROBLEM WITH THIS PRODUCT, CALL 434-929-2800 FOR A RETURN AUTHORIZATION (RA) NUMBER, THEN UPS SHIP TO:

T.R.U., 131 CRENNEL DR, MADISON HEIGHTS, VA 24572 OR MAIL TO: T.R.U., P.O. Box 1180, MADISON HEIGHTS, VA 24572.

ALL RETURNS MUST HAVE A RETURN AUTHORIZATION (RA) NUMBER.

**LEGAL**

ITEMS IN THIS PACKAGING MAY BE PATENT PENDING OR COVERED BY US PATENTS & REGISTERED TRADEMARKS. VISIT

WWW.TRUBALL.COM/LEGAL.HTML FOR A FULL LIST OF PATENTS & TRADEMARKS.

CHECK ALL SCREWS ON RELEASE TO INSURE TIGHTNESS BEFORE EACH USE. THINK AND ACT SAFELY!

THE FULKRUM AND FULKRUM FLEX BACK TENSION RELEASES ARE DESIGNED TO MATCH PERFECTLY IN DRAW LENGTH AND SIZE SPECIFICATIONS WITH THE THUMB TRIGGER ABYSS AND ABYSS FLEX RELEASES.



**ACHIEVE**  
**XP**

**DESIGNED FOR THE TOP ARCHERS IN THE WORLD**

- ULTRA HIGH MODULUS CARBON BAR, 2X STRONGER, CONTAINS THICKER LAYERS OF CARBON
- WEDGE LOCK BOW MOUNT BRACKET IS HANDS DOWN STRONGER THAN ANY OTHER
- IN-LINE TENSION ADJUSTMENT, ALLOWS THE SIGHT PIN TO STAY ON TARGET FROM SHOT TO SHOT
- STRONGER 10-32 WINDAGE LEAD SCREW
- ENLARGED DIAMETER WINDAGE AND ELEVATION KNOBS WITH CLICK LOCKS
- THINNER/WEIGHT REDUCING ELEVATION RAIL
- METAL SIGHT TAPE FOR COMPOUND MODELS ONLY (8 INCLUDED, 20 SOLD SEPARATELY)
- RECURVE SLEEVE LOCK APERTURE BLOCK (INCLUDED WITH ALL RECURVE MODELS)
- SIGHT PIN ALIGNMENT BLOCK (SOLD SEPARATELY FOR RECURVE MODELS)
- UHM 9" BAR FOR RECURVE SIGHTS AND UHM 6" & 9" BAR FOR COMPOUND SIGHTS

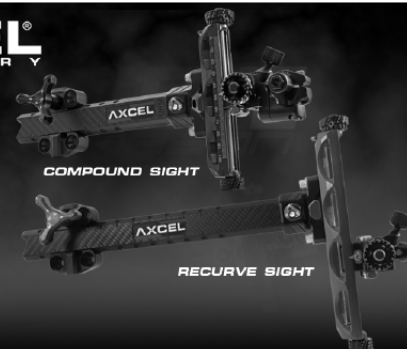

**STEP 7**

(2ea.) FKM-0006 (Retaining Screw)

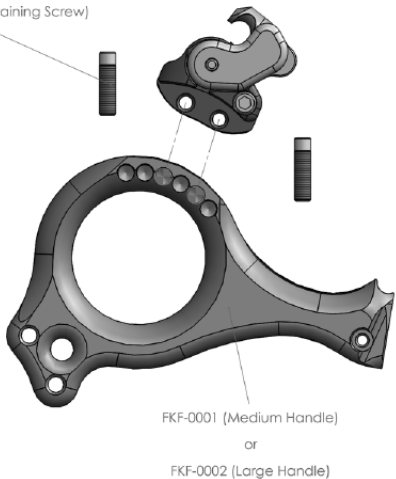

**STEP 7:** Line up a HEAD assembly with the holes shown (1 counter clockwise from right)  
Attach the HEAD to the HANDLE using (2) RETAINING SCREWS (FKM-0006)  
Tighten screws

**FIGURE 1**

FREAKSHOW  
**FULKRUM**  
FLEX



**TO CHANGE SEARS FROM CLICK TO NO CLICK INSTRUCTIONS:**

**STEP 1**

FKF-0003 (HEAD - MICRO ADJUST)

**STEP 1:**

Insert SPRING GUIDE (FKF-0006) into SPRING (LC 018AA 04S) and drop both into #8-32 tapped hole of HEAD (FKF-0003) as shown.

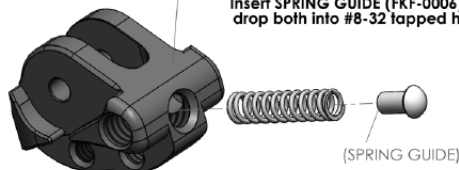

**COMFORT FLEX**  
TECHNOLOGY

**FINGER PIECE BREAKDOWN** **FIGURE 2**

3 FINGER PIECE

4 FINGER PIECES  
SOLD SEPARATELY

#2 flat washers

#2-56 x 5/16"

#2-56 x 5/16"

**\*\* DO NOT OVER TIGHTEN \*\***

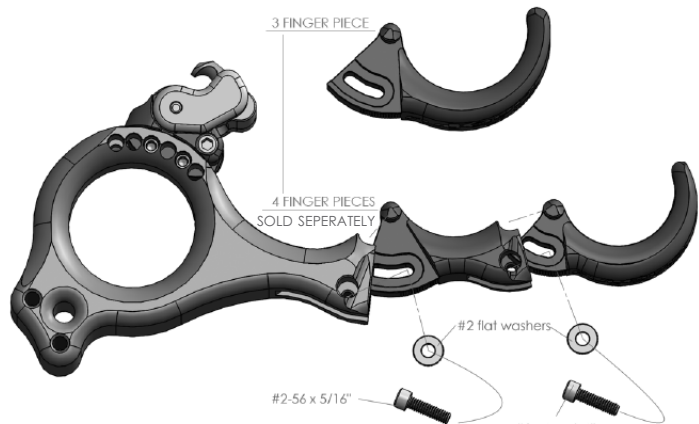

**STEP 2**

#8-32 X 1/4" SST OVAL POINT set-screw

OVAL POINT

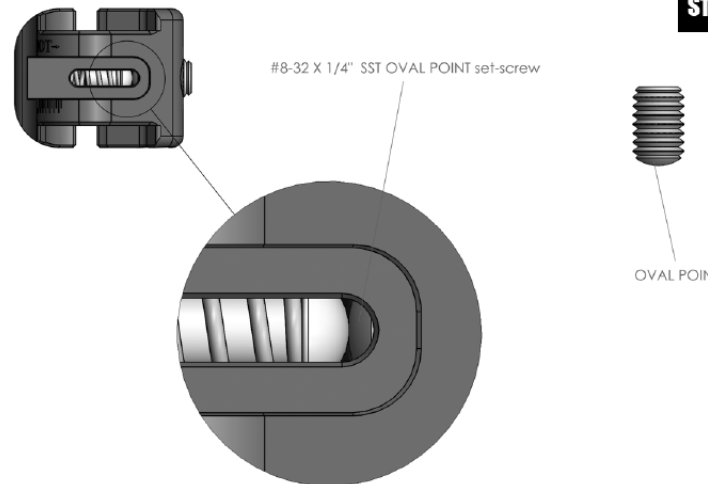

**STEP 2:**

Insert a #8-32 x 1/4" long SST Oval Point set-screw behind SPRING and SPRING GUIDE  
Tighten it until you can just see the set screw.  
- See drawing -

**STEP 3**

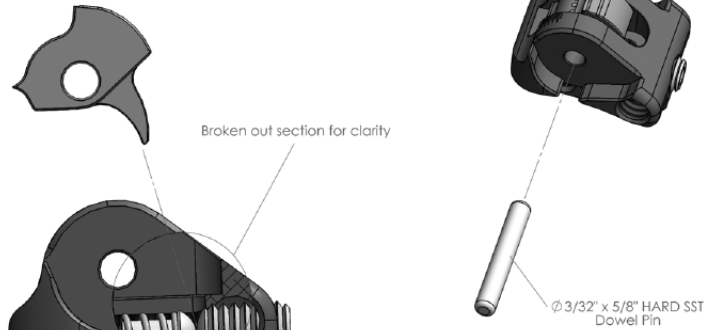

**STEP 3a:**  
Insert a SEAR (FKF-0005-B) into slot of HEAD aligning and pushing the "hook" between the SPRING GUIDE and set-screw

**STEP 3b:**  
While holding the SEAR in place push a  $\varnothing 3/32" \times 5/8"$  HARD Stainless Steel dowel pin thru both the HEAD and the SEAR. Leave equal parts of the dowel pin sticking out of both sides of the HEAD.  
Turn the set-screw clockwise so that is below the surface

**STEP 5**

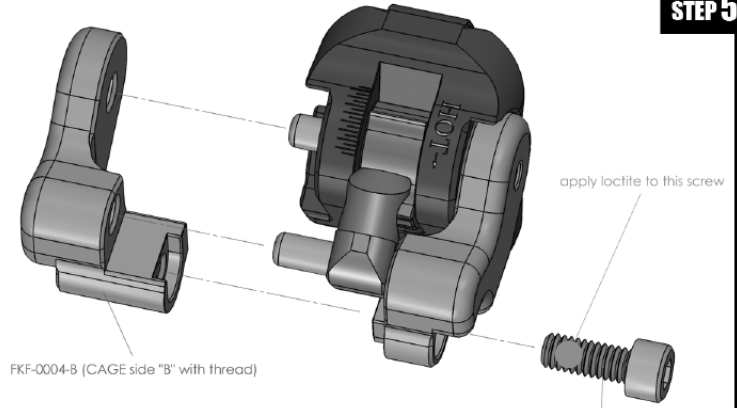

**STEP 5:**  
Slide the other half of the CAGE (FKF-0004-B threaded half) onto both dowel Pins  
Fasten in place with a #3-48 X 1/4" Stainless Steel SHCS  
use "liquid" blue Loctite on screw

**\*\*CAGE MUST ROTATE BACK AND FORTH FREELY AFTER ASSEMBLY\*\***

**STEP 4**

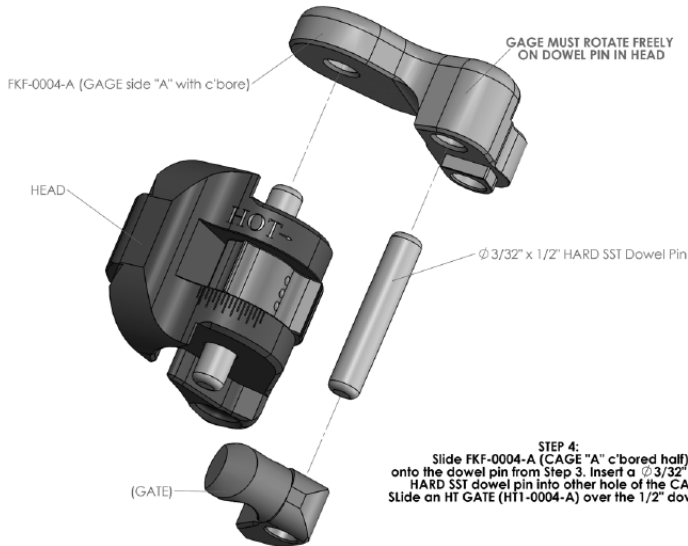

**STEP 4:**  
Slide FKF-0004-A (CAGE "A" c'bored half) onto the dowel pin from Step 3. Insert a  $\varnothing 3/32" \times 1/2"$  HARD SST dowel pin into other hole of the CAGE. Slide an HT GATE (HT1-0004-A) over the 1/2" dowel pin

**STEP 6**

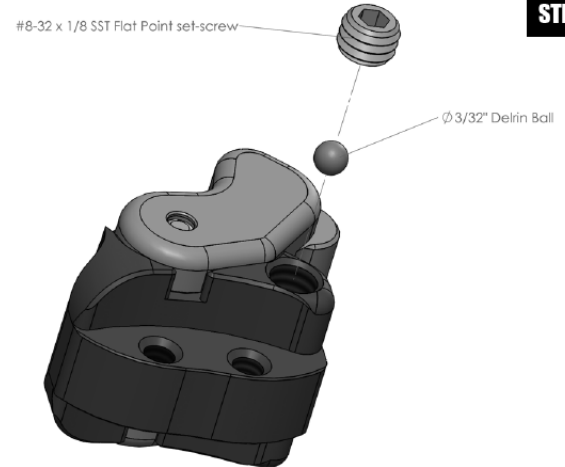

**STEP 6:**  
Drop a  $\varnothing 3/32"$  Delrin Ball into tapped hole as shown  
Back it up with a #8-32 x 1/8" Stainless Steel Flat Point set-screw  
turn set-screw 1 to 1-1/2 turns clockwise after it makes contact with cross set-screw