



MASTER VAPOR PUMPS LLC  
849 ALMAR AVE, SUITE C #209  
SANTA CRUZ, CA 95060  
MasterVaporPumps.com  
info@mastervaporpumps.com  
1-888-502-3303

## MODEL MVP LIQUID PUMP

The most valuable pump for solvent extraction processing

### Features & Benefits:

For volatile solvents (LPG/Ethanol)

Delivery and slurry circulation

Dual - Diaphragm

Electric powered explosion-proof motor

Stainless Steel wetted parts

Rated MAWP: LPG-350-PSI

### Pump Head Charge:

Maximum pumping outlet pressure 70 PSI

Center Section CO2 charge range 5 to 80 PSI

(10-15psi over inlet pressure recommended)

CO2 Inlet Size: 1/4 in. npt(f)

Maximum Pump Speed 135 cpm (cycle per minute)

Process Inlet and Outlet Size: 1 in. npt

Non-reactive CO2 gas is used to charge pump head

CO2 gas is safer than air for driving the pumping

CO2 tank IS NOT PROVIDED (cannot ship filled tanks)

CO2 gas regulator with gauges is provided with pump assembly

CO2 gas is non-flammable & non-explosive should a diaphragm ever leak

Motor is coupled to diaphragms with patented gas pressure charged chamber

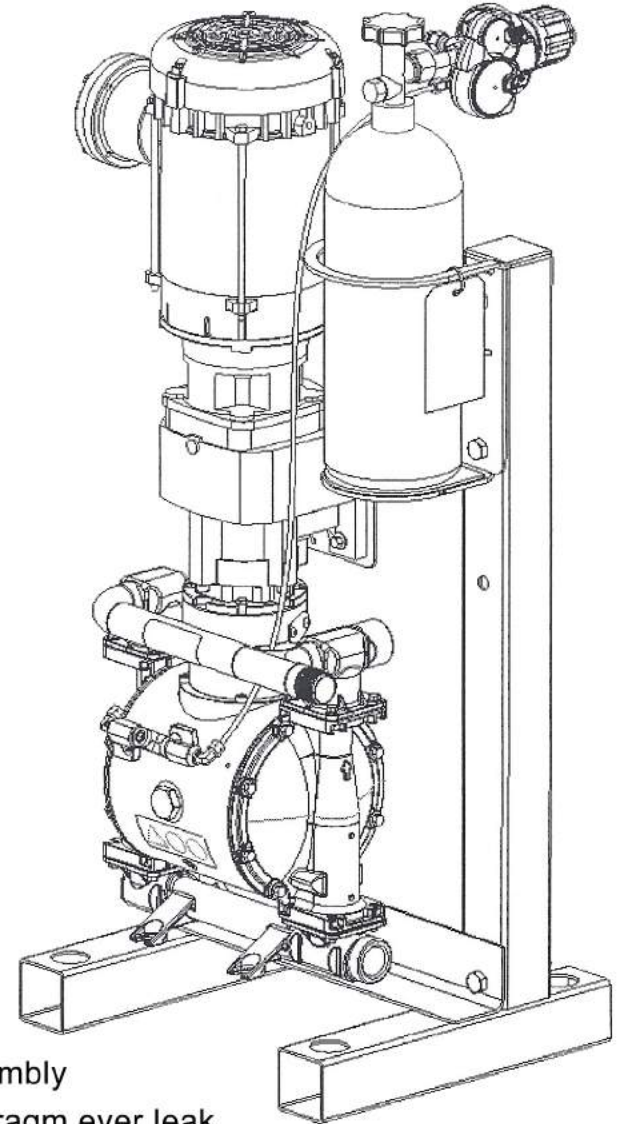

### Electrical & Mechanical:

Electric Motor: Explosion proof for C1D1 Hazardous areas

Electric Motor: 2HP, 3,600 rpm, 60Hz

Motor Options: Available in both Single-Phase and Three-Phase

Sound Pressure (tested 3.28 from Equipment) 80.5dBa

Weight 173.2 lbs