



MASTER VAPOR PUMPS LLC
849 ALMAR AVE, SUITE C #209
SANTA CRUZ, CA 95060
MasterVaporPumps.com
info@mastervaporpumps.com
1-888-502-3303

MODEL MVP-150

The most valuable pump for solvent extraction processing.

FEATURES & BENEFITS:

- Certified system gas recovery pump
- Positive displacement LP-Gas extraction pump
- Electric powered double diaphragm gas compressor
- Designed especially for LP-Gas vapor recovery
- Will also pull deep vacuum in chambers
- Ideal for butane and butane/propane mix vapor recovery processes
- Recovers 100% propane vapor when used with recovery tank cooling
- Can pull vacuum back through the pump when evacuating a system
- Passes liquid condensation without damage
- Explosion-proof motor rated for C1D1 areas
- Three-phase and single-phase models available
- Continuous 100% duty cycle – run 24/7
- No air compressor needed
- Patented pump drive technology
- No rotating or moving seals
- Can run dry without damage
- Can stall under pressure without damage
- Can start against full load and pressure
- No driving air used; cannot leak air into the system
- Maximum pumping pressure output is adjustable
- No lubrication in the pump heads; no contamination of product
- Meets NFPA 58 requirements for LP-Gas – rated LPG 350 PSI
- Compliant with NFPA and UL standards for C1D1 motors and LPG vapor recovery
- Meets Class 1 Division 1 hazardous area facility requirements (when installed correctly)
- Three-phase motors compatible with VFD (variable frequency drive) for speed control of pumping
- Easy DIY diaphragm replacement or internal cleaning when needed
- Simple DIY stainless steel reed valve replacement if ever needed
- One year manufacturer's warranty (see Operation Manual)

Made in the USA

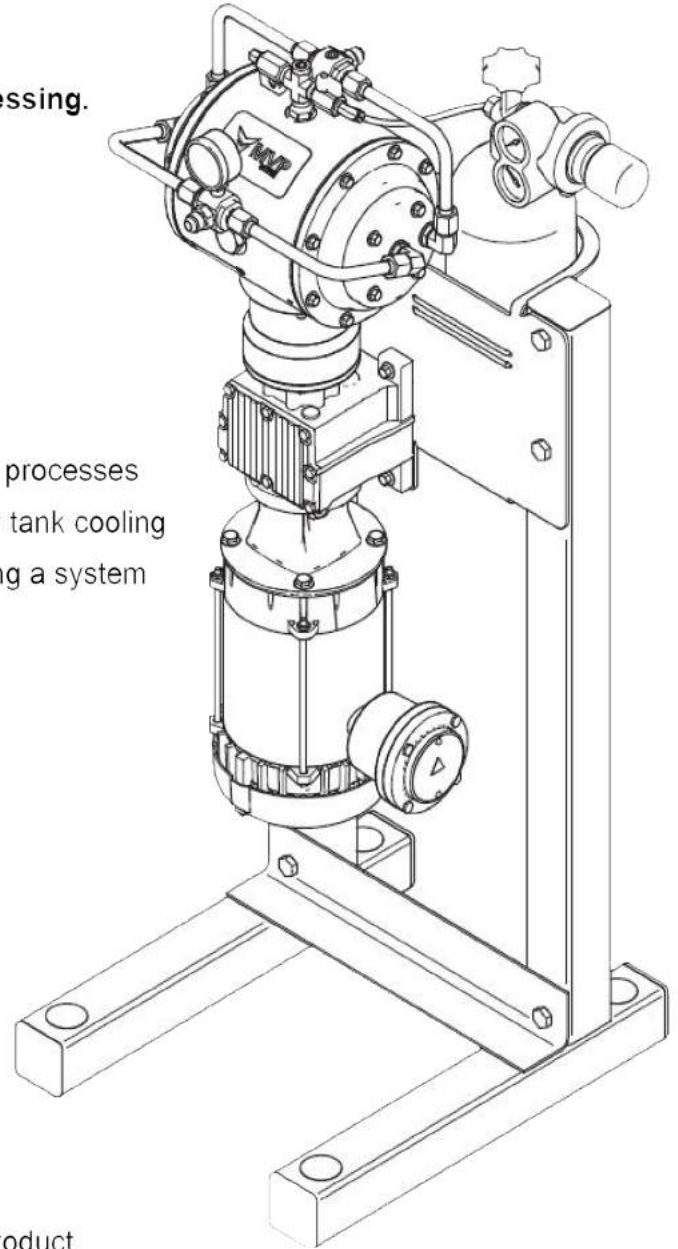

continued.....

PERFORMANCE FACTOIDS:

Recover LP-Gas vapor at **OVER 6 CFM** (cubic feet per minute)

Recover butane at up to **1.5 LB/MIN** (pounds per minute)

Recover and recondense butane at **18 GPH** (gallons per hour)

Maximum pumping outlet pressure: **150 PSI** (10.3 bar)

Maximum pumping inlet vacuum produced: **27 InHg** (0.91 bar)

Maximum pumping speed: **220 cpm** (cycles per minute)

Pump static withstand pressure rating: **375 PSI** (25.9 bar)

Materials: pressure section: stainless steel; diaphragms: **FKM**; reed valves: stainless steel

Optional PTFE diaphragms kit available

Process gas temperature range: **FKM -40°-275°F** (-40°-135°C); **PTFE +40°-220°F** (4°-104°C)

Recommended FKM replacement schedule: every 1000 hours running time

Air temperature range for motor/gearbox operation: **32°-104°F** (0°-40°C)

PUMP HEAD CHARGE:

Motor is coupled to diaphragms with patented gas pressure charged chamber

Pumping outlet pressure runs about 10 PSI lower than the charge gas pressure level

Non-reactive CO₂ gas is used to charge the pump head

CO₂ gas is safer than air for driving the pumping

CO₂ gas is non-flammable and non-explosive with LPG (should a diaphragm ever leak)

CO₂ gas regulator with gauges is provided with pump assembly

CO₂ tank is operator provided (cannot ship filled tanks) – from any welding supply shop

Pump charge gas supply: standard (#20) 5 LB tank of industrial CO₂

Typical CO₂ gas usage: <0.2 SCFH (very little); estimated life of charge gas tank: 1 year

Maximum Center section CO₂ charge: **150 PSI** (10.3 bar)

ELECTRICAL & MECHANICAL:

Electric motor: explosion proof for C1D1 hazardous areas; rated **Class I Gr C & D, Class II Gr F&G**

Electric motor: **2 HP, 3600 rpm, 60 Hz**

Motor option: Model MVP-6CFM-1PH: **Single-phase: 115/208-230V, 13.4/6.7 FLA** (full load amps)

Motor option: Model MVP-6CFM-3PH: **Three-phase: 208-230/460V, 3.3/1.65 FLA**, Inverter-rated

Pump speed: **190 CPM** (cycles per minute) at 60 HZ

Noise: sound pressure measured 1 meter from pump: 80.5 dBa

Porting: process inlet and outlet: **1/2" JIC-male**

Added ports for optional pressure gauges: inlet and outlet: 1/4" FNPT

Inlet & outlet ports at ideal equipment connection heights 46" and 41" above floor

Size: **17.0" x 19.9" base x 46" tall**; minimum use of valuable floor space

Weight: 182.5 lb (82.8 kg)