



4184 E. Conant st., Long Beach, CA 90808
 Tel. 800-500-3519 Fax. 310-900-1066
www.turboairinc.com

Project :

Model # :

Item # :

Qty :

Available W/H :

Approval :

Cheesemelters

Model : TACM-24



≡ FEATURES & BENEFITS ≡

- *Stainless steel front, sides and interior*
- *Adjustable gas valve*
- *Protective screen over infra-red burner*
- *Chrome plated heavy duty rack*
- *Unit can be mounted over Radiance range, counter and also on a wall*
- *CSA certified for safety / sanitation for USA and Canada*



Model	Weight (lbs.)	Length (inches)	Total BTUs
TACM-24	105	24	20,000
TACM-24-LP	105	24	20,000

Cheesemelters

Model : TACM-24

DATA	TACM-24	TACM-24-LP
Gas Type	NAT	LPG
Gas Connection	3/4"	3/4"
Regulator	1	1
Gas Pressure	5.W.C"	10.W.C"
BTU	20,000	20,000
DIMENSIONAL DATA		
Ext. Length Overall (inch)	24 (610mm)	24 (610mm)
Ext. Depth Overall (inch)	20 1/2 (519mm)	20 1/2 (519mm)
Ext. Height Overall (inch)	19 (483mm)	19 (483mm)
Weight (lbs.)	105	105

Design and specifications subject to change without notice.
Actual shipping weight may differ due to extra packing materials for product protection.

■ WARRANTY : 1 Year Parts and Labor Warranty

■ Range mounting brackets standard

■ OPTIONAL ACCESSORIES

- 24" wall mounting brackets: RCM1018
- Hood mount shelf to mount on 36" range: RCM1021
- Hood mount shelf to mount on 48" range: RCM1022
- Hood mount shelf to mount on 60" range: RCM1023

PLAN VIEW

(unit : inch)

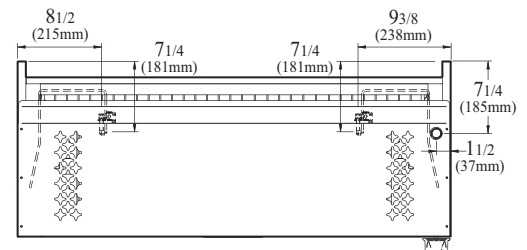

TOP VIEW

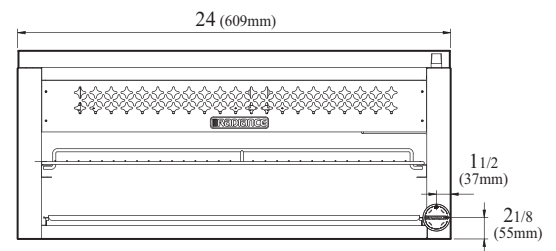

FRONT VIEW

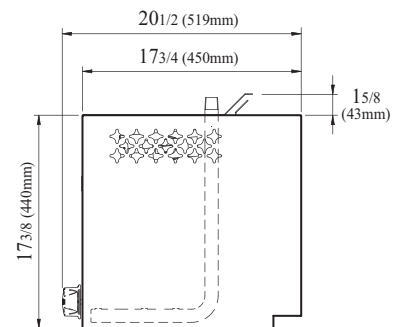

SIDE VIEW

Ver.20190517



- Turbo Air : 800-627-0032
- GK : 800-500-3519
- Warranty : 800-381-7770
- AC : 888-900-1002