



Project \_\_\_\_\_  
 Item # \_\_\_\_\_  
 Quantity \_\_\_\_\_

# SPECTRUM

## Commercial Countertop Gas Griddles, Natural / LP

Models: NGGD-24M / NGGD-36M / NGGD-48M

The Spectrum Gas Griddles are designed with durable stainless steel construction and cool-touch front plate rail.

These units are equipped with infinite heat controls, high-performance burners, and removable grease drawer.

Includes an LP conversion kit.

### Standard Features

- ◆ High performance burners, each with output of 30,000 BTU
- ◆ Infinite heat controls
- ◆ 5" wide cool-touch stainless steel front plate rail provides safety and knob protection
- ◆ Stainless steel insulated double-wall body, adjustable legs 4" to 6" and grease drawer with weep hole and baffle; non-skid feet
- ◆ 3/4" polished steel griddle plate with side and back splash guard
- ◆ 3-1/2" full width grease trough
- ◆ Standing pilot ignition system, one per burner
- ◆ 3/4" rear gas connection with regulator
- ◆ Conversion kit allows the use of propane or natural gas
- ◆ CSA listed for commercial and indoor use
- ◆ One year parts and labor warranty

### Models

#### NGGD-24M

Burners: 2  
 BTU/total per HR: 60,000  
 Griddle surface: 24" x 20-3/4"

#### NGGD-36M

Burners: 3  
 BTU/total per HR: 90,000  
 Griddle surface: 36" x 20-3/4"

#### NGGD-48M

Burners: 4  
 BTU/total per HR: 120,000  
 Griddle surface: 48" x 20-3/4"



NGGD-24M



NGGD-36M



NGGD-48M



### Accessories

#### GRILL SCRAPERS

- SCRP-14 16" Heavy-duty aluminum grill scraper
- SCRP-16 16" Aluminum grill scraper
- SCRP-12 12" Aluminum grill scraper

#### GRIDDLE CLEANERS

- GSH-1 Griddle Screen Holder
- GSN-4 Grill Screen, fits with GSH-1
- GBH-2 Griddle Brick Holder
- GBK-348 Grill brick, fits with GBH-2

Winco®, DWL International Trading, LLC

www.wincous.com  
 equipsales@wincous.com

East Coast: 65 Industrial Road, Lodi, NJ 07644  
 Tel. 1.888.946.2682 | Fax: 1.888.946.2632

West Coast: 14950-14952 Valley View Avenue, La Mirada, CA 90638  
 Tel. 1.888.946.2652 | Fax: 1.562.926.5678



# SPECTRUM Gas Griddles

Models:  
NGGD-24M  
NGGD-36M  
NGGD-48M

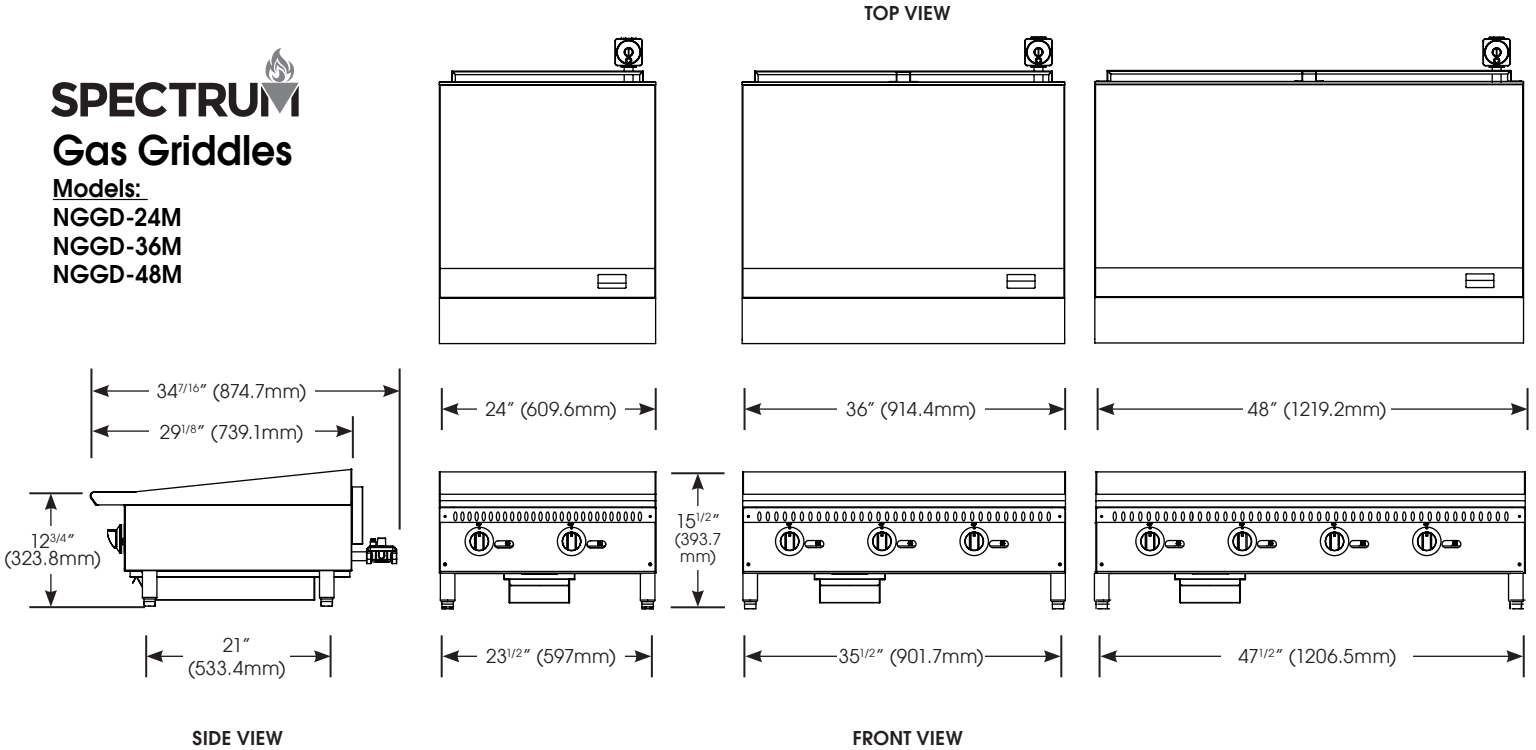

## Specifications

MODEL	DESCRIPTION	# OF BURNERS	BTU/ BURNER	TOTAL BTU/HR	PRESSURE IN. W.C.	DIMENSIONS			GRIDDLE SURFACE		SHIP WEIGHT
						LENGTH	DEPTH	HEIGHT	LENGTH	DEPTH	
NGGD-24M	Spectrum Gas Griddles	2	30,000	60,000	4" / 10"	24" (609.6mm)	34-7/16" (87.3mm) <i>includes gas inlet pipe at rear</i>	15-1/2" (393.7mm)	24" (609.6mm)	20-3/4" (527mm)	196 lbs (89 kg)
NGGD-36M		3		90,000		36" (914.4mm)			36" (914.4mm)		284 lbs (129 kg)
NGGD-48M		4		120,000		48" (1219.2mm)			48" (1219.2mm)		355 lbs (161 kg)

## Gas Requirements and Information

- Natural or LP gas main supply required
- 3/4" NPT male connection, all units supplied with natural gas and convertible LP gas regulator

## THESE UNITS ARE SUITABLE FOR INSTALLATION ON NON-COMBUSTIBLE SURFACE(S) ONLY.

**Combustible clearances:** 6" sides (152mm) / 6" rear (152mm) / 4" floor (102mm)

**Noncombustible clearances:** 0" sides (0mm) / 6" rear (152mm) / 4" floor (102mm)

## Product Specs

### Gas Griddles

The Gas Griddle models NGGD-24M / NGGD-36M / NGGD-48M as manufactured by Winco®, Lodi, NJ 07644.

The Gas Griddle shall be rated at 30,000 BTU per burner, 3/4" rear gas connection with regulator and overall height from 13-1/2" to 15-1/2". The Gas Griddle shall consist of 3/4" polished steel griddle plate with side and back splash guard, two (2) / three (3) / four (4) burners, standing pilot ignition system, stainless steel insulated body, grease drawer with weep hole and baffle. Natural gas supplied standard, conversion kit included for LP. Not to be used on casters.

CSA listed for commercial and indoor use.

Warranty consists of one year parts and labor.

## Winco®, DWL International Trading, LLC

www.wincous.com  
equipsales@wincous.com

**East Coast:** 65 Industrial Road, Lodi, NJ 07644  
Tel. 1.888.946.2682 | Fax: 1.888.946.2632

**West Coast:** 14950-14952 Valley View Avenue, La Mirada, CA 90638  
Tel. 1.888.946.2652 | Fax: 1.562.926.5678