

TURBO AIR REFRIGERATOR MANUFACTURER
Turbo air
 more durable, efficient, beautiful

4184 E. Conant St.
 Long Beach, CA 90808
 Tel. 310-900-1000
 Fax. 310-900-1077
www.turboairinc.com

Project:	
Model #:	
Item #:	
Available W/H:	Qty:
Approval:	
AIA #:	SIS #:
CSI Section 11400	

Milk Coolers - Dual Sided Door

Milk Coolers
 Super Deluxe Series

Model : TMKC-49-2-WS-N6



≡ FEATURES & BENEFITS ≡

■ **Hydrocarbon refrigerants (R-600a)**

With innovative and eco-friendly technology, Turbo Air brings you hydrocarbon refrigerators designed to meet DOE's Energy Conservation Standards in 2017 and to use EPA's SNAP Program approved HC refrigerants. Hydrocarbon refrigerants do not deplete the ozone layer and have very low contribution to global warming (ODP-0, GWP-3).

■ **Convenient bottom floor drain standard with hose adapter**

Floor drain is located in the rear on the right hand side for easy clean out. The hose adapter allows for convenient connecting to drain hose.

■ **Extended cleaning-free condenser**

Electrodeposition coating is applied to prevent condenser corrosion, and wire condenser are applied to prevent dust from accumulating.

■ **Sturdy and clean, durable cabinet construction**

Exterior is made of white coated steel with stainless steel interior and doors.

■ **Direct cooling type**

■ **Exterior digital thermometer standard for easy visibility**

Exterior digital temperature display allows easy reading and precise and constant temperature. This level of precision allows milk to remain fresh and safe over an extended period of time.

■ **High-density polyurethane insulation**

The entire cabinet construction is foamed-in-place using high density, environmental friendly CFC free polyurethane insulation.

■ **Stainless steel self-service doors have drop front feature and hold-open flip-up top lid**

■ **4" dia. swivel casters standard for easy movement, two with brakes to lock the unit in place**

■ **Refrigerator holds 33°F ~ 38°F for the best in milk preservation**

NATURAL Refrigerant

ETL Intertek

ETL Intertek

5 YEAR WARRANTY

7 YEAR WARRANTY

ENERGY STAR® Qualified

Model	# of Doors	# of Floor Rack	CU./FT.	Crate Capacity (13 x 13 x 11-5/8)	HP	AMPS	Crated Weight (lbs.)	L x D* x H† (inches)
TMKC-49-2-WS-N6	4	2	18.3	12	1/5	7	352	49 x 32 ⁷ / ₈ x 40 ⁵ / ₈

Model : TMKC-49-2-WS-N6

SPECIFICATIONS	
Voltage	115/60/1
Plug Type	 NEMA 5-15P
Full Load Amperes	7
Compressor HP	1/5
Cord Length (ft.)	9
Refrigerant	R-600a
Net Capacity (cu. ft.)	18.3
Ext. Length (in.)	49 (1245mm)
Ext. Depth (in.) *	327/8 (836mm)
Ext. Height (in.) †	405/8 (1031mm)
# of Doors	4
Crate Capacity (13" x 13" x 115/8")	12
Gross Weight (lbs.)	352

Design and specifications subject to change without notice.

Actual shipping weight may differ due to extra packing materials for product protection.

* Depth does not include 1-3/8" for door support bumpers.

† Height does not include 1-1/4" for door handles and door support bumpers.

- **WARRANTY : 5 Year Parts and Labor Warranty
7 Year Compressor Warranty**

▪ STANDARD FEATURES

- Door locks standard
- Heavy duty floor racks standard
- Door support bumpers standard

PLAN VIEW

(unit : inch)

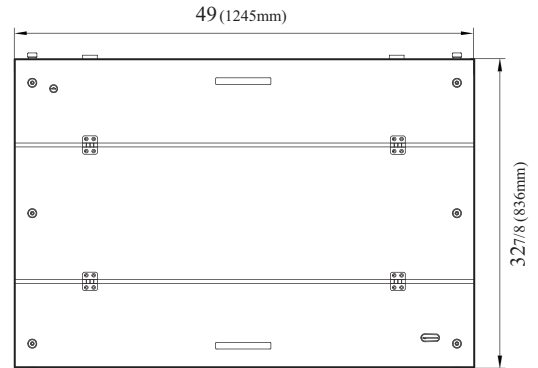

TOP VIEW

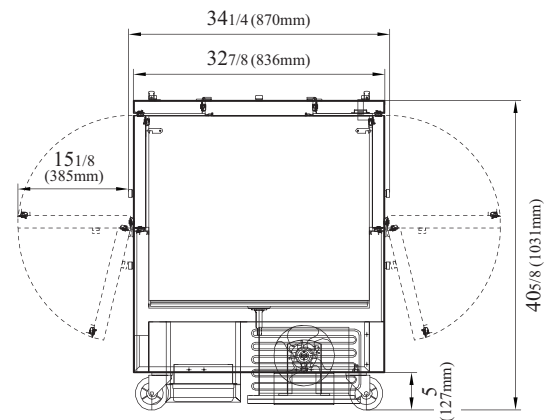

SIDE VIEW

Ver.20230103



ENERGY STAR®
Qualified

- Turbo Air : 800-627-0032
- GK : 800-500-3519
- Warranty : 800-381-7770
- AC : 888-900-1002



Continued product development may necessitate specification changes without notice.