

REFRIGERATOR MANUFACTURER
Turbo air
 more durable, efficient, beautiful

4184 E. Conant St.
 Long Beach, CA 90808
 Tel. 310-900-1000
 Fax. 310-900-1077
www.turboairinc.com

Project:	
Model #:	
Item #:	
Available W/H:	Qty:
Approval:	
AIA #:	SIS #:
CSI Section 11400	

Island Display Cases

Self-Serve Merchandisers

Patented Self-Cleaning Condenser

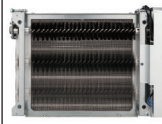

This product is equipped with a fine mesh filter to the front of the condenser to catch dust, and a rotating brush that moves up and down daily to remove excess buildup outward and away.

Model : TIOM-48CCB-N



FEATURES & BENEFITS

Self-Cleaning Condenser

The accumulation of dust in the condenser causes the failure or breakdown of refrigerators. Refrigerators run normally until they reach a certain level of accumulation. At some point, when they are over the limit, their performance drops quickly resulting in damage to, or disposal of the stored products in refrigerators. The Self-Cleaning Condenser device keeps the condenser clean and prevents system failure by automatically brushing daily.

Hydrocarbon refrigerant (R-290)

With innovative and eco-friendly technology, Turbo Air brings you hydrocarbon refrigerators designed to meet DOE's Energy Conservation Standards in 2017 and to use EPA's SNAP Program approved HC refrigerants. Hydrocarbon refrigerants do not deplete the ozone layer and have very low contribution to global warming (ODP-0, GWP-3).

Modern design

By harmonizing curvature and rigidness, our modern style product designs are user-friendly while maintaining the highest product visibility and aesthetics. The glass front shield optimize the merchandiser's display effects of fresh salads, sandwiches, desserts and beverages.

Designed to enhance impulsive sales

Ideal for eye-catching displays and convenient access with fast service in high traffic area.

LED lighting on top panel and canopy

Brighter and longer lasting LED lights provide attractive, enhanced illumination compared to fluorescents. It saves energy by producing less heat, while maximizing the visibility in the display area.

Tempered glass product stopper

Simple plug-in installation

Patented self-contained system, no plumbing required

Digital electronic thermostat with defrost control

Price tag rails standard

NATURAL Refrigerant



Model	CU./FT.	# of Tiers	HP	AMPS	Crated Weight (lbs.)	L x D x H* (inches)
TIOM-48CCB-N	23.7	3	3/4 x 4	15.5	853	47 1/8 x 48 3/8 x 64 1/2

Model : TIOM-48CCB-N

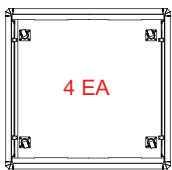
ELECTRICAL DATA	
Voltage	220/60/1
Plug Type	 NEMA L6-20P
Full Load Amperes	15.5
Compressor HP	3/4 x 4
Cord Length (ft.)	97/8
Refrigerant	R-290
DIMENSIONAL DATA	
Net Capacity (cu. ft.)	23.7
Ext. Dimension (L x D x H*) (in.)	47 1/8 x 48 3/8 x 64 1/2
# of Tiers	3
# of Casters	 4 EA
Net Weight (lbs.)	706
Gross Weight (lbs.)	853

Design and specifications subject to change without notice.
Actual shipping weight may differ due to extra packing materials for product protection.
* Height does not include 1-1/8" for caster height.

■ **WARRANTY : 2 Year Parts and Labor Warranty**
Additional 3 Year Warranty on Compressor

■ **STANDARD FEATURES**

- Bolt height adjustable up to 2 3/4"
- 2" dia. swivel casters

** Lead time applies. Please contact your sales representative for more details to order.

■ **Recommended operating conditions**

TIOM models are designed to operate in an environment where temperature & humidity do not exceed 75°F and 55% respectively. Units should not be installed near HVAC vents, fans or doorways that will disrupt the air curtain and compromise the function of the cabinet. Air curtain models will run most efficiently when completely loaded with product.

■ **OPTIONAL ACCESSORIES**

- 6" leveling seismic leg (1/2", 13 TPI): 30221M0700

PLAN VIEW

(unit : inch)

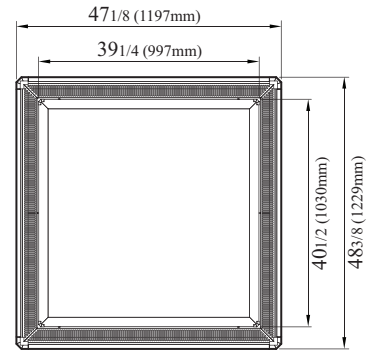

TOP VIEW

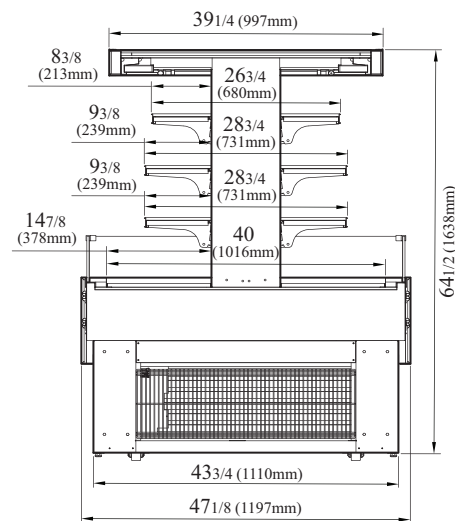

FRONT VIEW

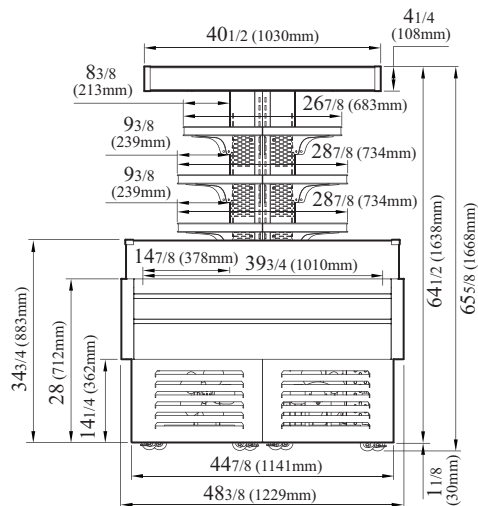

SIDE VIEW

Ver.20220725



- Turbo Air : 800-627-0032
- GK : 800-500-3519
- Warranty : 800-381-7770
- AC : 888-900-1002