



Your Solutions Partner

# Specifications

F.O.B. Sedalia, Missouri 65301



**E-4-DLSS**

### OPTIONS:

- 14 gauge tops
- Heated base module
- Sliding Doors
- 3-phase wiring
- Adaptor plates
- Casters (add cord and plug), 5" swivel with locks
- Casters (add cord and plug), 5" swivel no lock
- Veneered panels
- Powder coat paint colors
- Foodshields
- Trayslides
- 1/2" poly cutting surface added to integral top

### AGENCY LISTINGS:



DUKE MANUFACTURING CO.

2305 N. Broadway

St. Louis, MO 63102

800.735.3853 Toll Free

314.231.5074 Fax

www.dukemfg.com

SS-1029 Thurmaduke DLPG-DLSS

### Approval Stamp(s):

### PRODUCT INFORMATION:

PROJECT: \_\_\_\_\_

ITEM: \_\_\_\_\_

QUANTITY: \_\_\_\_\_

### MODEL:

Thurmaduke® Steamtables

Hot Food Units - Electric - Deluxe

- E-2-DLPG/E-2-DLSS 2 top openings
- E-3-DLPG/E-3-DLSS 3 top openings
- E-4-DLPG/E-4-DLSS 4 top openings
- E-5-DLPG/E-5-DLSS 5 top openings
- E-6-DLPG/E-6-DLSS 6 top openings

### TOP:

- One piece. 16 gauge, 300 Series stainless steel
- Top openings die-stamped. 12" x 20"
- Integral carving/work surface

### HEAT COMPARTMENTS:

- Sealed wells with drains copper manifolds and brass master valve
- 750 watt element at 120, 208 or 240 volt/single or 3-phase
- Robertshaw thermostat w/indicator light per section
- Master toggle switch w/indicator light - entire unit
- 12" x 20" stainless steel liner, 6-1/2 deep

### BODY AND INTERIOR SHELF:

- 300 Series stainless steel or paint grip steel
- End panels
- 6" polished stainless steel adjustable legs

### INTEGRAL DISHSHELF:

- Heavy gauge, one piece stainless steel - 8-1/2" wide
- Housing for control knobs, thermostats and master switch
- Wire knob guards

Specification subject to change



**WARNING:** Cancer and Reproductive Harm - [www.p65warnings.ca.gov](http://www.p65warnings.ca.gov)

REV B 5/1/2018

THURMADUKE® STEAMTABLES - HOT FOOD - ELECTRIC - DELUXE

Catalog No. TST-DELECHOT

A.I.A. File No. 35-C-13

# Thurmaduke®

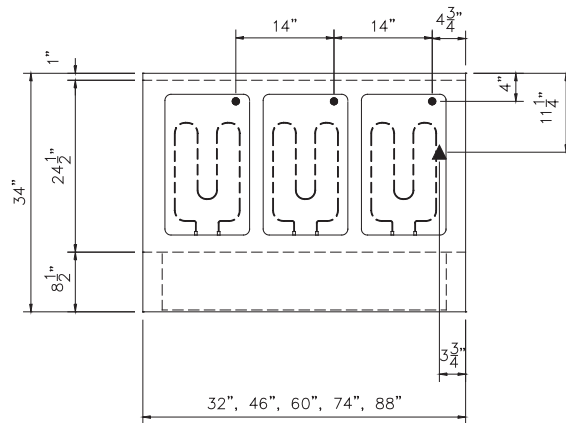

TOP VIEW

LEGEND	
▲	ELECTRICAL CONNECTION
●	DRAIN LOCATION

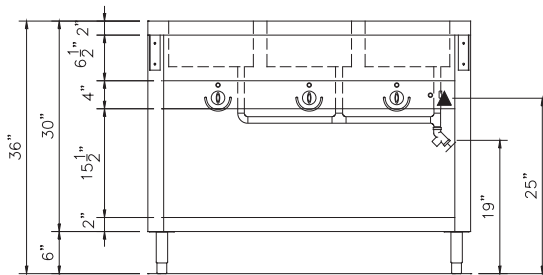

FRONT VIEW

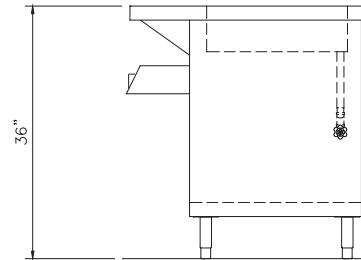

RIGHT SIDE VIEW

DIMENSIONS:

FREIGHT CLASS: 150

Model		Length		Width		Height		Top Openings	Cube ft. Crated	Weight	
Enameled	Stainless	in	cm	in	cm	in	cm			lbs	kg
E-2-DLPG	E-2-DLSS	32	81.3	34	86.4	36	91.4	2	27.0	255	115.9
E-3-DLPG	E-3-DLSS	46	116.8	34	86.4	36	91.4	3	38.1	335	152.3
E-4-DLPG	E-4-DLSS	60	152.4	34	86.4	36	91.4	4	49.2	410	186.4
E-5-DLPG	E-5-DLSS	74	188.0	34	86.4	36	91.4	5	60.2	495	225.0
E-6-DLPG	E-6-DLSS	88	223.5	34	86.4	36	91.4	6	71.3	595	270.5

ELECTRICAL SPECIFICATIONS:

Model	120 Volt - 750 watt elements			208 Volt - 750 watt elements			240 Volt - 750 watt elements		
	Watts	Amps	NEMA	Watts	Amps	NEMA	Watts	Amps	NEMA
E-2-DLPG/SS	1500	12.5	5-15	1500	7.2	6-20	1500	6.4	6-20
E-3-DLPG/SS	2250	18.8	L5-30	2250	10.8	6-20	2250	9.4	6-20
E-4-DLPG/SS	3000	25.0	5-50	3000	14.4	6-20	3000	12.5	6-20
E-5-DLPG/SS	3750	31.3	5-50	3750	18.0	L6-30	3750	15.9	6-20
E-6-DLPG/SS	N/A			4500	21.6	L6-30	4500	18.8	L6-30

Cord and NEMA plug NOT included



**Duke Manufacturing Co.**  
2305 N. Broadway  
St. Louis, MO 63102

Phone: 314-231-1130  
Toll Free: 1-800-735-3853  
Fax: 314-231-5074

www.dukemfg.com