

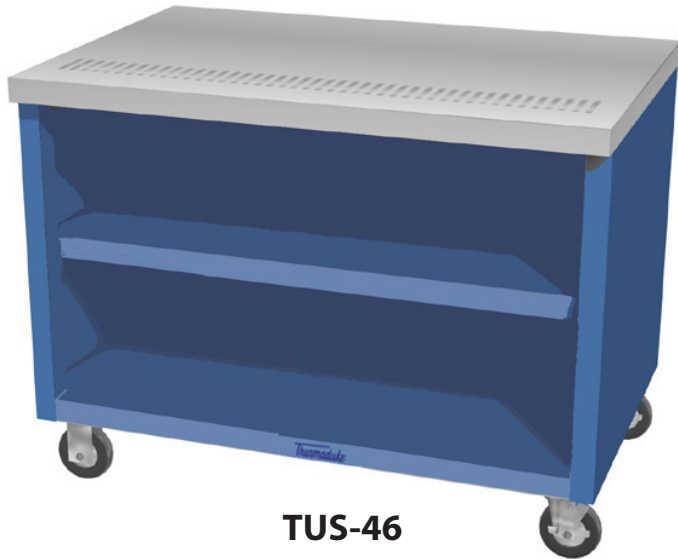

Your Solutions Partner

# Specifications

F.O.B. Sedalia, Missouri 65301



**TUS-46**

**OPTIONS:**

- 14 gauge tops
- Internal Locking device
- Double-service drain trough
- Workshelves
- Trayslides
- Recessed top in lieu of flat top
- Partial length drip trough
- Sliding/Hinged doors
- 6" adjustable stainless steel legs
- Veneered plastic laminate panels on body
- Powder coat paint colors
- 6', 8' or 10' cord and plug
- Kickplates s/s or p/g

**Approval Stamp(s):**

**PRODUCT INFORMATION:**

PROJECT: \_\_\_\_\_

ITEM: \_\_\_\_\_

QUANTITY: \_\_\_\_\_

MODEL:

**Thurmaduke Serving Systems  
Urn Stand Units**

- TUS-32** 32" length unit/.26" length drip trough
- TUS-46** 46" length unit/40" length drip trough
- TUS-60** 60" length unit/54" length drip trough
- TUS-74** 74" length unit/68" length drip trough

**TOP:**

- 16 gauge, 300 Series stainless steel
- Sound-deadening
- 4" wide drain trough, 6" shorter than top
- 1" drain
- Stainless steel anti-splash grid, removable

**BODY:**

- Choice of (12) powder coat paint colors.
- Stainless steel body
- Operator's side open to bottom shelf
- Side opposite operator and ends fully enclosed
- Intermediate and bottom shelves to match body
- NSF approved polyurethane casters, two with locks
- 7" high stainless steel rail on operator's side

**Agency Listings:**



Specification subject to change



DUKE MANUFACTURING CO.  
 2305 N. Broadway  
 St. Louis, MO 63102  
 800.735.3853 Toll Free  
 314.231.5074 Fax  
 www.dukemfg.com  
 SS-1172 Thurmaduke - Urn Stand

REV B 04/20/2020

THURMADUKE SERVING SYSTEMS - URN STAND

Catalog No. TSS-URN

A.I.A. File No. 35-C-13



# Thurmaduke Serving Systems Urn Stand Unit

A.I.A. File No. 35-C-13

Catalog No. TSS-URN

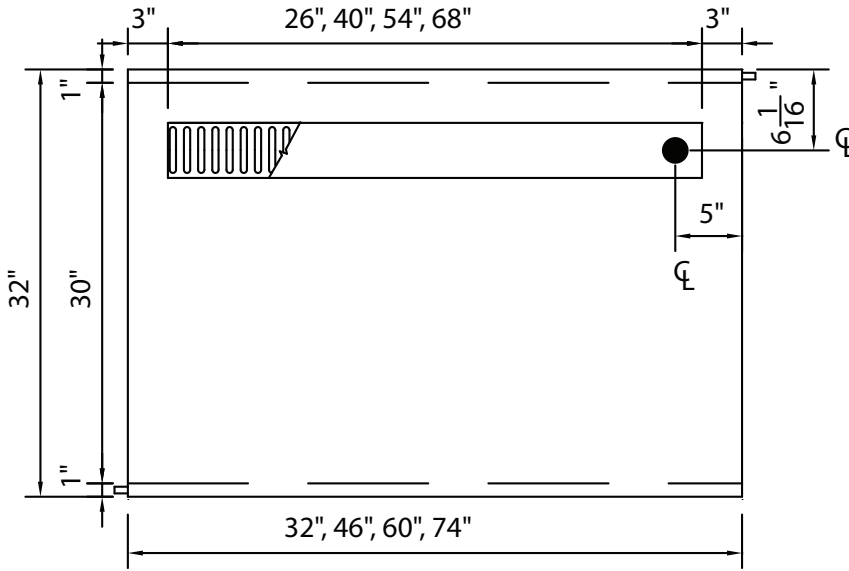

**TOP VIEW**

LEGEND	
●	Drain Location - Specify location of drain.

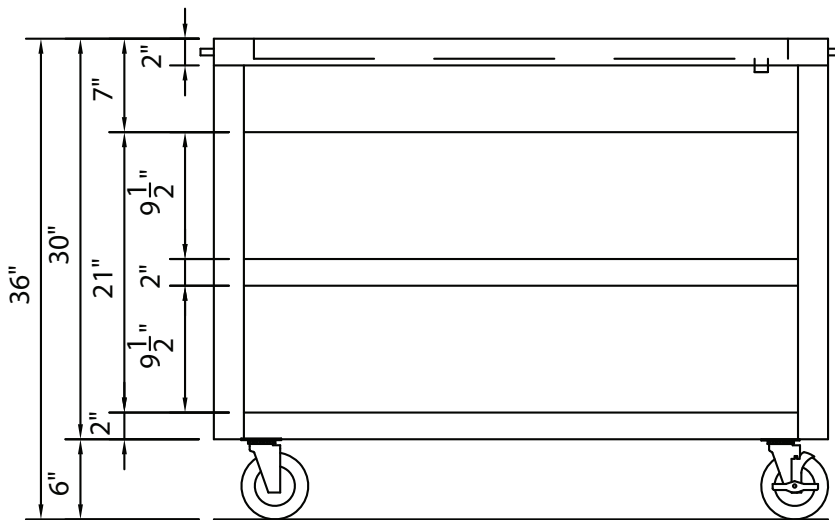

**FRONT VIEW**

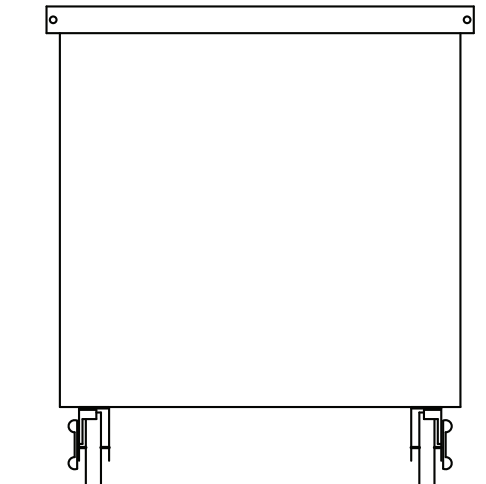

**RIGHT SIDE VIEW**

**DIMENSIONS:**

Freight Class: 150

Model	Length		Width		Height		Cube ft. crated	Weight		Drip Trough			
	in	cm	in	cm	in	cm		lbs	kg	Length		Width	
										in	cm	in	cm
TUS-32	32	81.3	32	81.3	36	91.4	34.8	275	125.0	26	66.0	4	10.2
TUS-46	46	116.8	32	81.3	36	91.4	47.7	325	147.7	40	101.6	4	10.2
TUS-60	60	152.4	32	81.3	36	91.4	60.5	375	170.5	54	137.2	4	10.2
TUS-74	74	188.0	32	81.3	36	91.4	73.3	425	193.2	68	172.7	4	10.2

THURMADUKE SERVING SYSTEMS - URN STAND



**Duke Manufacturing Co.**  
2305 N. Broadway  
St. Louis, MO 63102

Phone: 314-231-1130  
Toll Free: 1-800-735-3853  
Fax: 314-231-5074

www.dukemfg.com